

REV.	DATE	DCN #	DRAWING TREE #
		E0810007-V2	

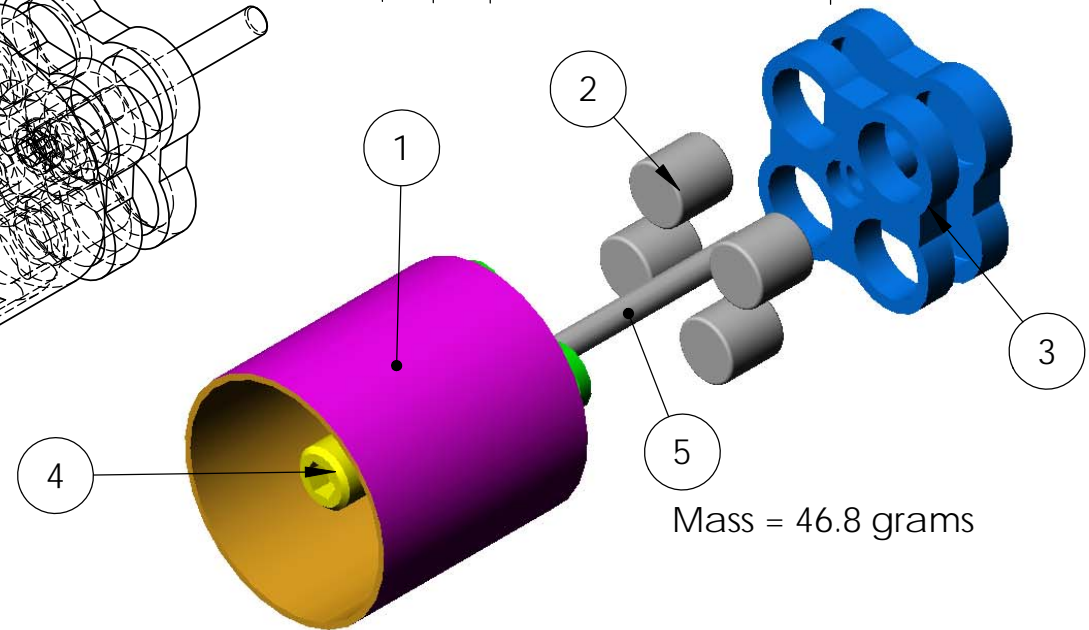

Mass = 46.8 grams

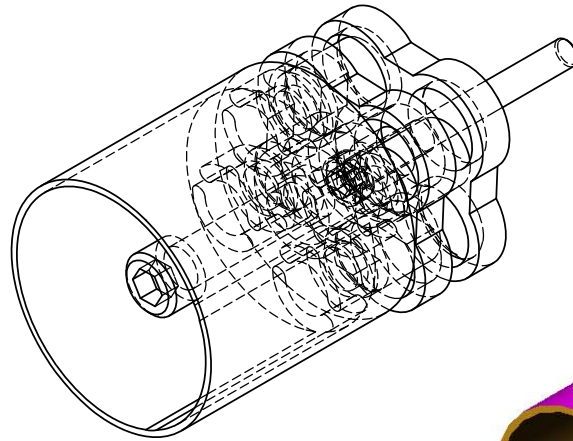
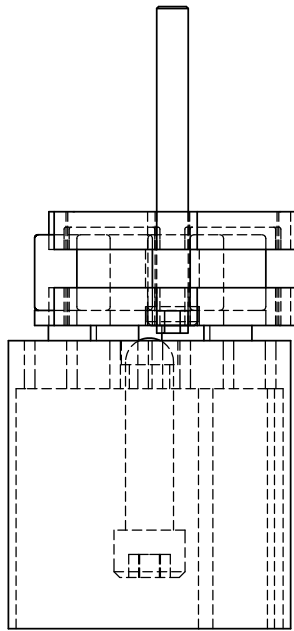
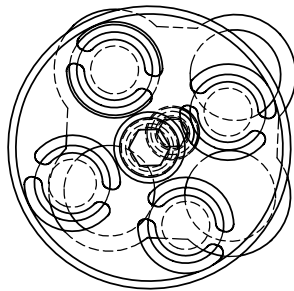

ITEM NO.	PART NUMBER	DESCRIPTION	Default/ QTY.
1	D030215	INTERFACE FOR MAGNETS	1
2	D020466	NICKEL PLATED MAGNET	4
3	D020475	2x2 COPPER ARRAY DAMPER	1
4	D030023	SCREW, SOCKET HEAD CAP, 1/4-20 UNC-2A X 1 LONG, ROUNDED END	1
5	D030735	PRESS FIT HEX PIN WITH SHCS	1
6	JAM NUT 1/4-20		2

NOTES: (UNLESS OTHERWISE SPECIFIED)

- REMOVE ALL SHARP EDGES, R.02 MIN.
- ALL MACHINING FLUIDS SHALL BE WATER SOLUBLE AND FREE OF SULFUR, CHLORINE AND SILICONE, SUCH AS CINCINNATI MILACRON'S CIMTECH 410 (STAINLESS STEEL)

DIMENSIONS ARE IN INCHES

TOLERANCES:  
 .XX ± --  
 .XXX ± --

ANGULAR ± -- °

MATERIAL

--

FINISH

	NAME	DATE
DRAWN	CIT	03 JUN 2003
CHECKED		
APPROVED		



SYSTEM ADVANCED LIGO

SUB-SYSTEM SUS

NEXT ASSY ETM (SINGLE PEND TEST)

PART NAME Cu DAMPER 2x2 ARRAY STRIPPED

SIZE DWG. NO. D030243 REV. V2

SCALE: NTS PROJECTION: SHEET 1 OF 1