

ISOMETRIC VIEW

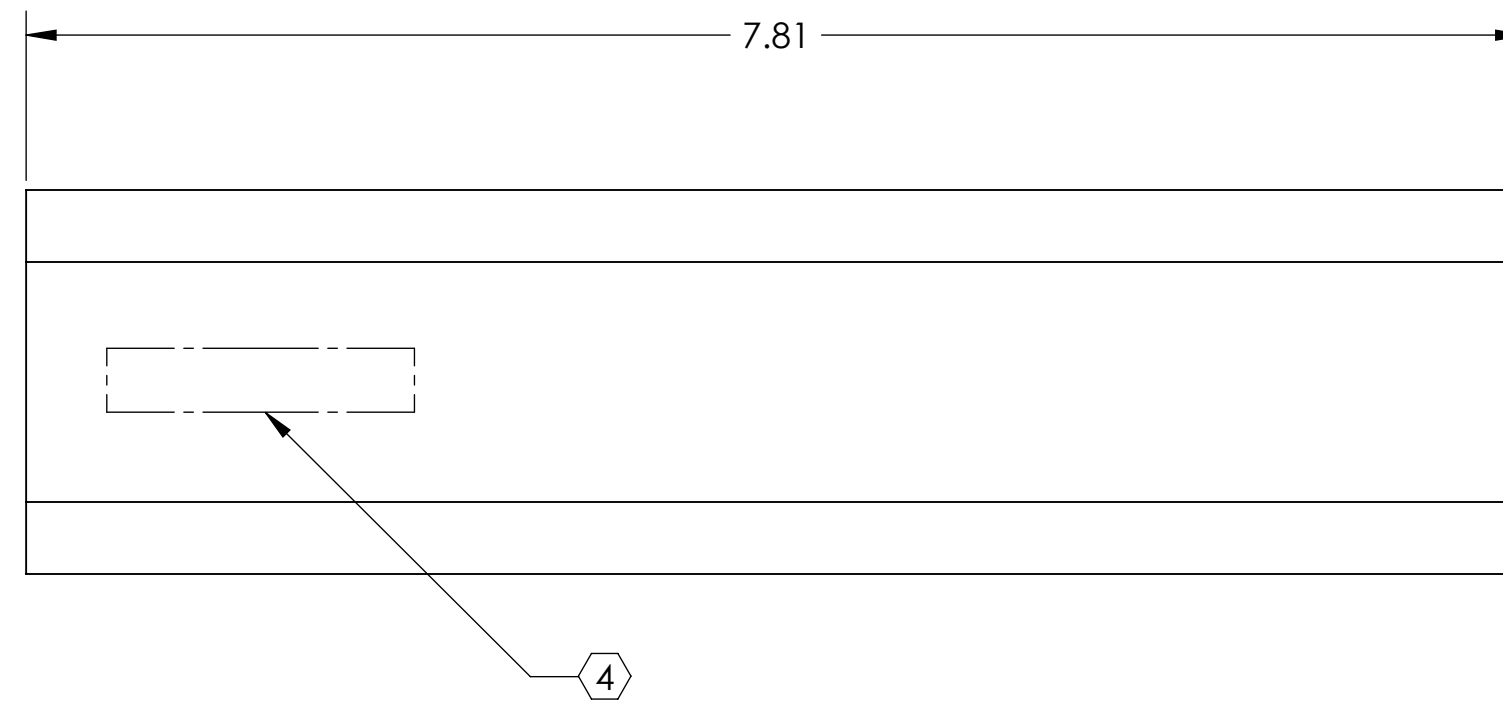
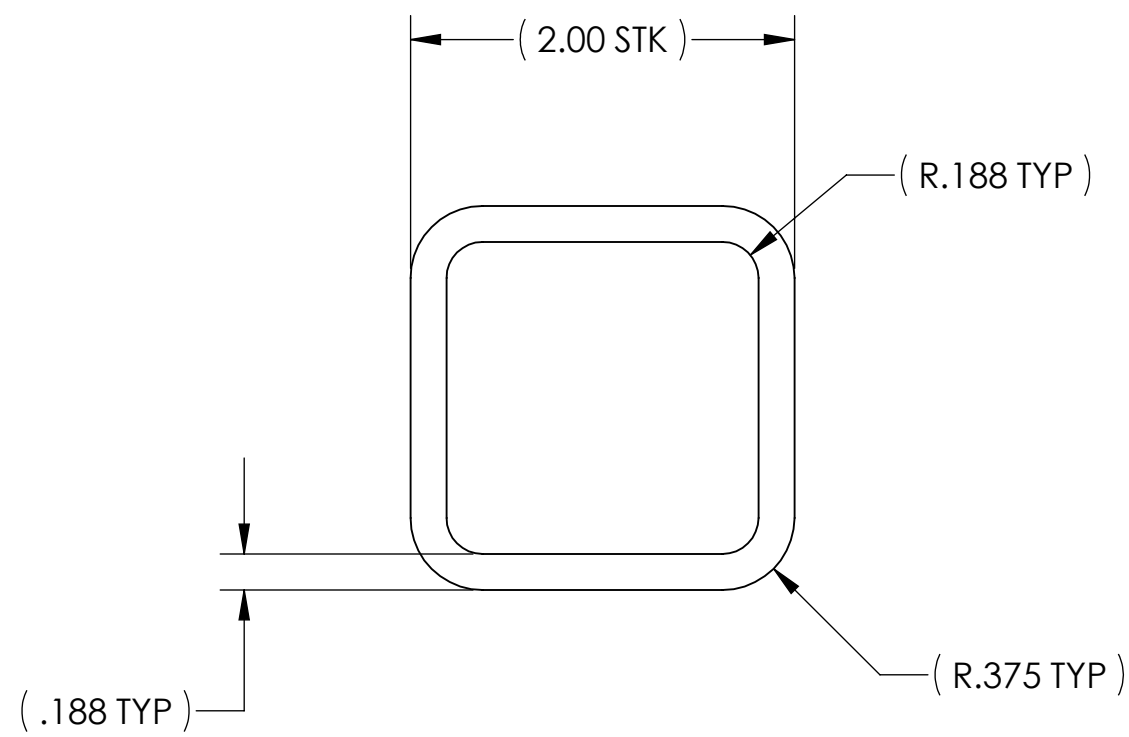

This piece is part of a weldment. Dimensions shown are approximate; weld induced shrinkage or fill, and post weld annealing and machining considerations are not included.
See D070442-v1 for required dimensions of structure after welding.

| | | | | |
|--|---------------------|---|---------------------|--|
| NOTES: (UNLESS OTHERWISE SPECIFIED) | | DIMENSIONS ARE IN INCHES | | CALIFORNIA INSTITUTE OF TECHNOLOGY MASSACHUSETTS INSTITUTE OF TECHNOLOGY IGR, GLASGOW UNIVERSITY GEO 600 GROUP |
| 1. REMOVE ALL SHARP EDGES, R.02 MIN. 2. DO NOT SCALE FROM DRAWING. 3. ALL MACHINING FLUIDS SHALL BE WATER SOLUBLE AND FREE OF SULFUR, CHLORINE AND SILICONE, SUCH AS CINCINNATI MILACRON'S CIMTECH 410 (SSTL) | | TOLERANCES: .XX ± .01 .XXX ± .005 ANGULAR ± 0.5° | | |
| ④ SCRIBE, ENGRAVE, OR MECHANICALLY STAMP (NO INKS OR DYES) DRAWING PART NUMBER AND REVISION ON NOTED SURFACE FOLLOWED ON THE NEXT LINE BY A THREE DIGIT SERIAL NUMBER. SERIAL NUMBERS START AT 001 FOR THE FIRST ARTICLE AND PROCEED CONSECUTIVELY. USE .07" HIGH CHARACTERS. EXAMPLE: DXXXXXX-VV, S/N 001. A VIBRATORY TOOL MAY BE USED. 5. L AND LN VARIANTS OF 304 SSTL ARE ACCEPTABLE. | | MATERIAL 304 SSTL | | SUB-SYSTEM SUS |
| FINISH 32 μinch | | NEXT ASSY HLTS STRUCTURAL WELDMENT | | PART NAME SIDE CROSS BEAM, THICK |
| DESIGNER D. BRIDGES | DATE 20 OCT 2008 | SIZE C | DWG. NO. D080282 | REV. V1 |
| DRAWN B. MOORE | DATE 01 APR 2009 | SCALE: 1:1 | PROJECTION: | SHEET 1 OF 1 |
| CHECKED D. BRIDGES | DATE 01 APR 2009 | | | |