

NOTES CONTINUED:

Ⓢ BAG ALL ITEMS INDIVIDUALLY AND MARK OR TAG EACH BAG WITH DRAWING NUMBER, REVISION, AND QUANTITY. EXAMPLE: DXXXXXX-VY, QTY: 1

REV.	DATE	DCN #	DRAWING TREE #
v1	18 AUG 2009	E0900244	-
-	-	-	-
-	-	-	-

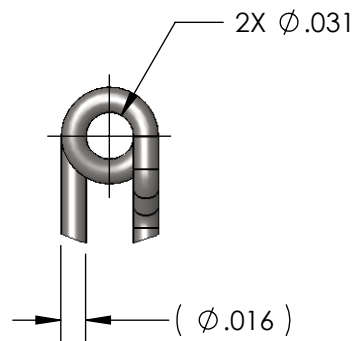
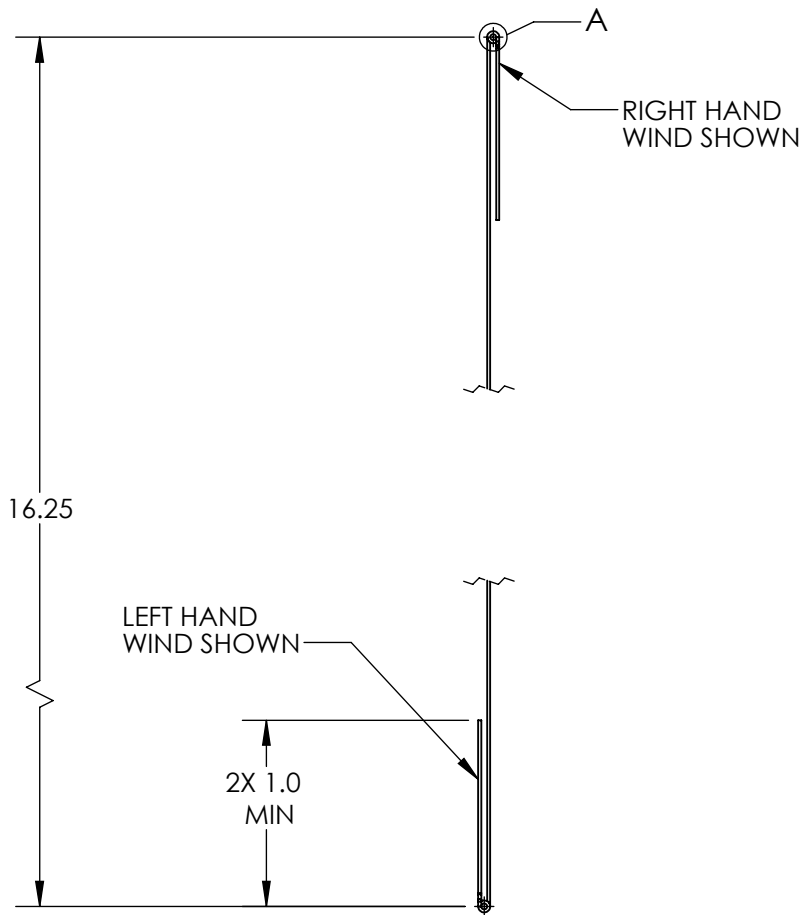

DETAIL A SCALE 8 : 1

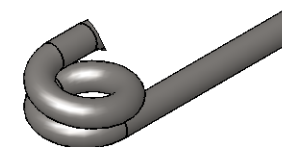

2 COILS WIND AS SHOWN TYPICAL

NOTES AND TOLERANCES: (UNLESS OTHERWISE SPECIFIED)

DIMENSIONS ARE IN INCHES

TOLERANCES:

.XX ± .03  
.XXX ± .010

ANGULAR ± 1.0°

1. INTERPRET DRAWING PER ASME Y14.5-1994.
2. REMOVE ALL SHARP EDGES, R.02 MIN.
3. DO NOT SCALE FROM DRAWING.
4. ALL MACHINING FLUIDS SHALL BE WATER SOLUBLE AND FREE OF SULFUR, CHLORINE AND SILICONE, SUCH AS CINCINNATI MILACRON'S CIMTECH 410.

MATERIAL STEEL MUSIC WIRE

FINISH -

**LIGO** CALIFORNIA INSTITUTE OF TECHNOLOGY  
MASSACHUSETTS INSTITUTE OF TECHNOLOGY

SYSTEM ADVANCED LIGO SUB-SYSTEM AOS

NEXT ASSY D0900586

PART NAME

UPPER MUSIC WIRE

DESIGNER		
DRAFTER	N. Nguyen	17 AUG 2009
CHECKER	M. Smith	20 AUG 2009
APPROVAL	D. Coyne	20 AUG 2009

SIZE DWG. NO. A D0900584

REV. v1

SCALE: 1:1 PROJECTION: SHEET 1 OF 1