

D0900859_GS-13_Pod_TopHat, PART PDM REV: X-016, DRAWING PDM REV: X-009

- NOTES CONTINUED:**
- 5. SCRIBE, ENGRAVE, OR MECHANICALLY STAMP (NO INKS OR DYES) DRAWING PART NUMBER, REVISION (AND VARIANT OR "TYPE" IF APPLICABLE) ON NOTED SURFACE OF PART FOLLOWED ON THE NEXT LINE WITH A THREE DIGIT SERIAL NUMBER. SERIAL NUMBERS START AT 001 FOR THE FIRST ARTICLE AND PROCEED CONSECUTIVELY. USE MINIMUM 0.12" HIGH CHARACTERS, UNLESS THE SIZE OF THE PART DICTATES SMALLER CHARACTERS. A VIBRATORY TOOL MAY BE USED.
EXAMPLE: DXXXXXX-VY, TYPE-XX, S/N XXX
 - 6. CONFIGURATION OF KNIFE EDGE GASKET RELIEF AREAS AND THEIR RELATIONSHIP TO THE SURROUNDING BOLT PATTERN AND MATING FLANGE AREA SHALL CONFORM TO A 2.75" CF FLANGE REF. NOR-CAL 275-150N.
 - 7. WELDS TO BE EXTERNAL FUSION GTAW UHV CONTINUOUS AND FULL PENETRATION.
 - 8. JOINT CONFIGURATION TO BE DETERMINED BY VENDOR.
 - 9. ALL WELDMENTS MUST BE FABRICATED IN COMPLIANCE WITH SPECIFICATIONS DEFINED IN LIGO DOCUMENT E0900048.
 - 10. EXTERNAL SURFACE OF POD IS EXPOSED TO HIGH VACUUM. ALL SURFACES MUST BE FREE OF: WELD RESIDUE, SCALE, DIRT AND INK.
 - 11. ABRASIVE REMOVAL TECHNIQUES ARE NOT ACCEPTABLE.
 - 12. ALL PARTS SHALL BE MANUFACTURED IN ACCORDANCE WITH LIGO SPECIFICATION E0900364.
 - 13. APPROXIMATE WEIGHT = 27.3LB.
 - 14. THREADED HOLES SHALL BE PRODUCED TO A .004-.006 OVERSIZE CONDITION ON THE PITCH DIAMETER BASED ON A 2B CONDITION.
 - 15. ELECTROPOLISH AFTER WELDING PER BEST COMMERCIAL PRACTICE. MASK CF FLANGE GASKET SURFACES.
 - 16. TACK WELD CAN BE USED IF NEEDED FOR SET UP. VOLUME MUST VENT TO INSIDE.

REV.	DATE	DCN #	DRAWING TREE #
V1	4 FEB 2010	E0900444-X0	E1000025
V2	23 MAR 2010	E0900444-V1	E1000025
V3	29 APR 2010	E1000148-V1	E1000025

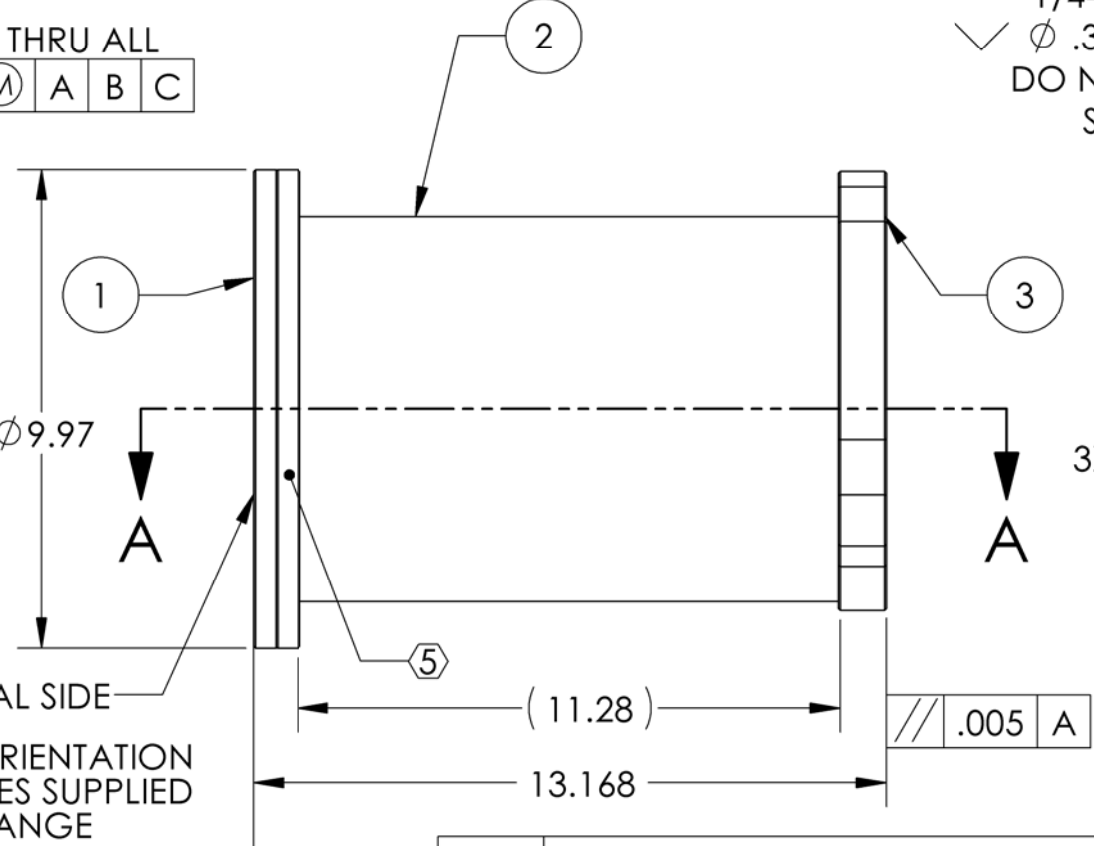
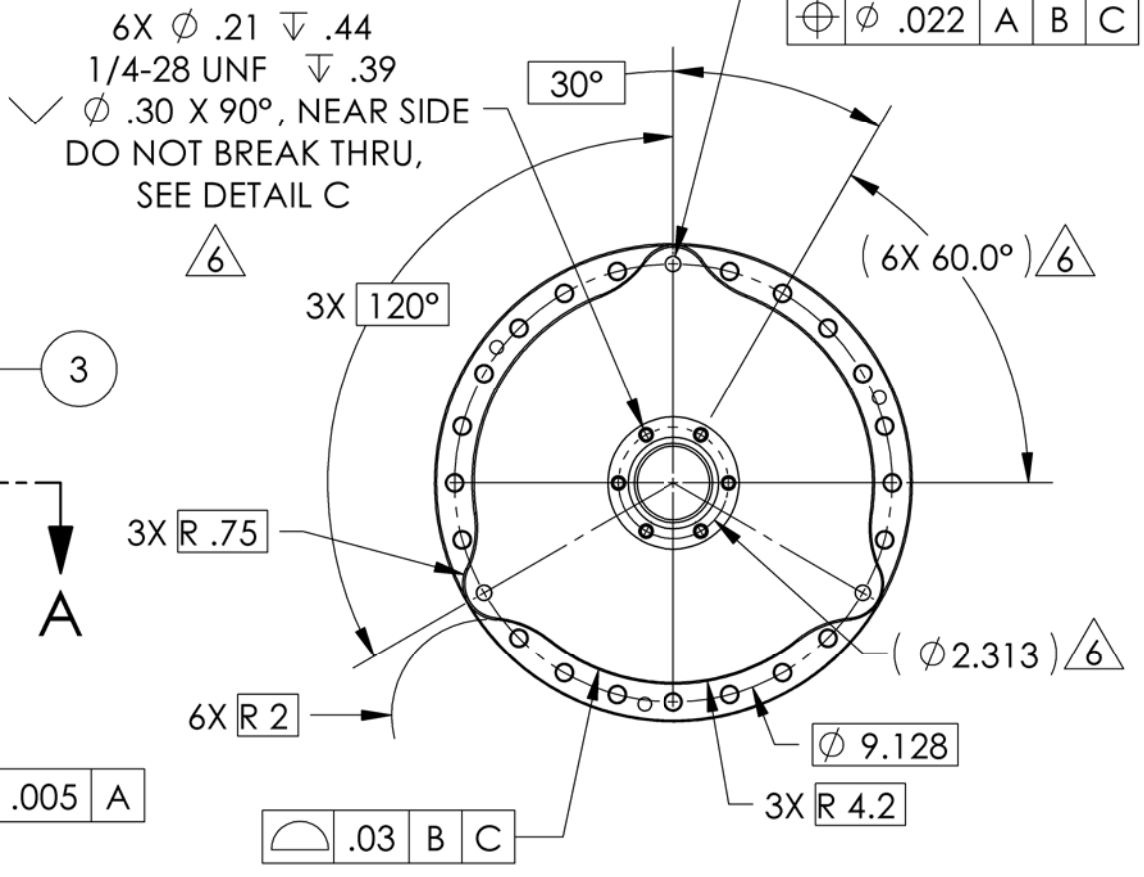
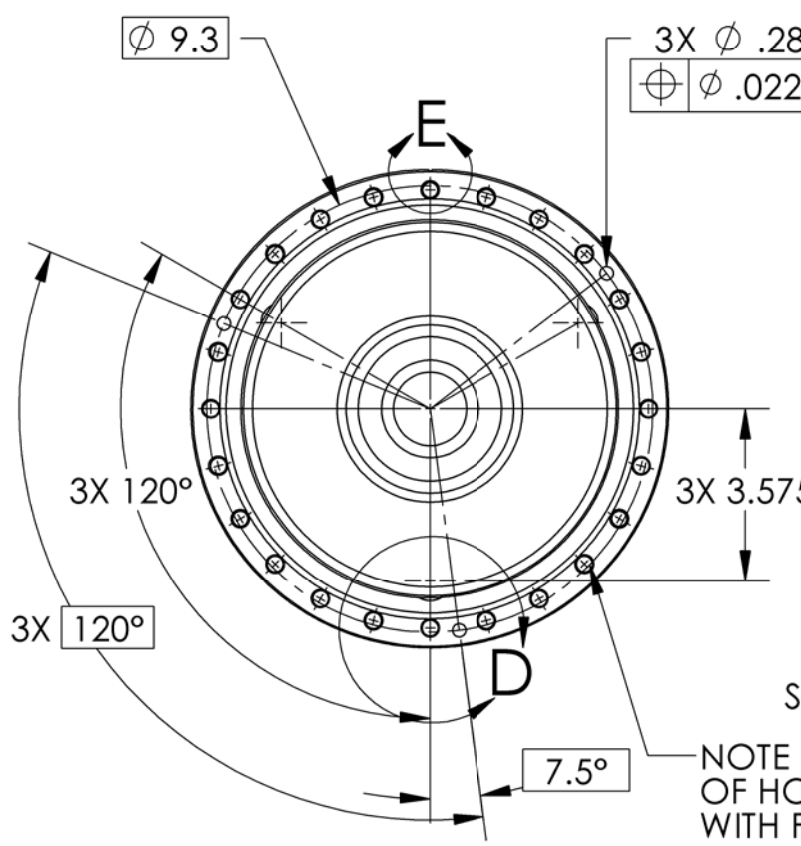
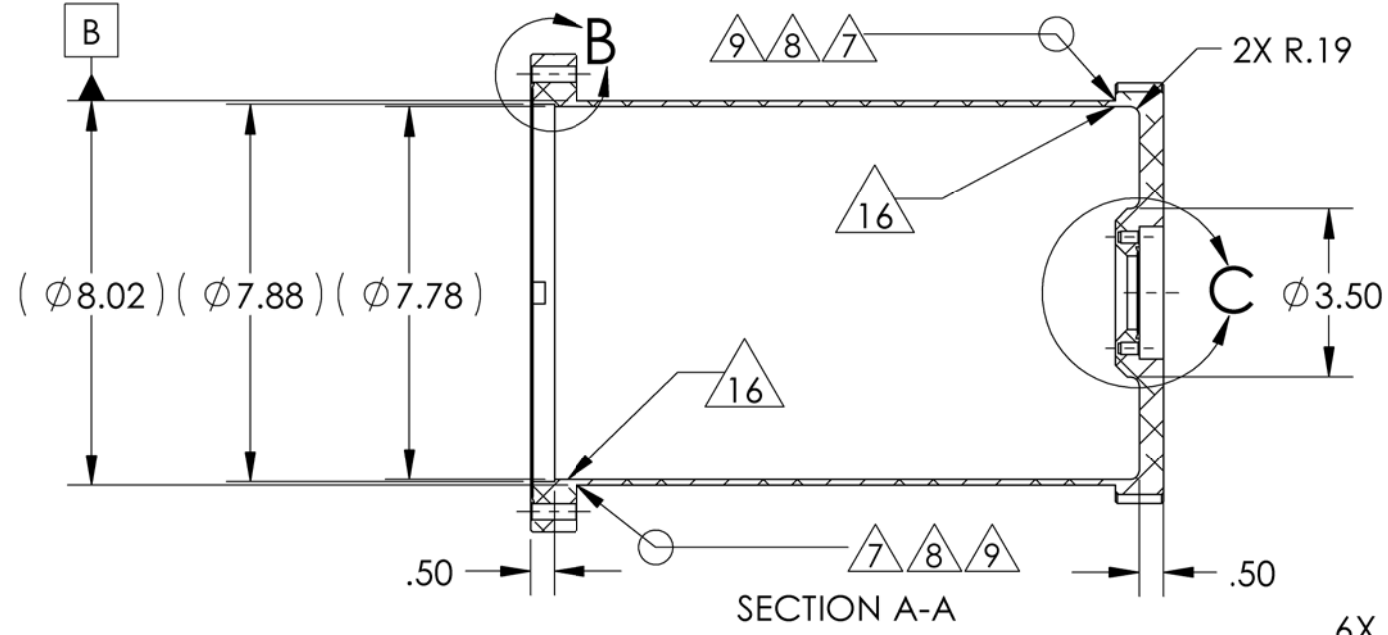

ITEM NO.	PART NUMBER	DESCRIPTION	MATERIAL	REQ
3	N/A	10" CF BLANK FLANGE MODIFIED AS NOTED	304 SSSL	1
2	NOR-CAL SST-800 OR EQUIV.	8" OD TUBING CUT TO LENGTH	304 SSSL	1
1	NOR-CAL 1000-800NT OR MACHINED TO SAME DIMENSIONS AND TOLERANCES	10" CF FLANGE	304 SSSL	1



NOTES AND TOLERANCES: (UNLESS OTHERWISE SPECIFIED)

DIMENSIONS ARE IN INCHES
 TOLERANCES:
 .XX ± .015
 .XXX ± .005
 ANGULAR ± 0.1°

1. INTERPRET DRAWING PER ASME Y14.5-1994.
 2. REMOVE ALL SHARP EDGES, R.02 MIN.
 3. DO NOT SCALE FROM DRAWING.
 4. ALL MACHINING FLUIDS MUST BE FULLY SYNTHETIC, FULLY WATER SOLUBLE AND FREE OF SULFUR, SILICONE, AND CHLORINE.

LIGO CALIFORNIA INSTITUTE OF TECHNOLOGY
 MASSACHUSETTS INSTITUTE OF TECHNOLOGY

ADVANCED LIGO SUB-SYSTEM SEI

GS13 Pod Top Hat

DESIGNER	S.BARNUM	4 FEB 2010	SIZE	DWG. NO.	REV.
DRAFTER	M.HILLARD	4 FEB 2010	B	D0900859	v3
CHECKER	F.Matichard	4 FEB 2010			
APPROVAL	K.MASON	4 FEB 2010			

MATERIAL: 304 SSSL FINISH: 63 μinch NEXT ASSY: D0900857 SCALE: 1:4 PROJECTION: SHEET 1 OF 2

D0900859_GS-13_Pod_TopHat_PART PDM REV: X-016, DRAWING PDM REV: X-009

DETAIL D
SCALE 1 : 2

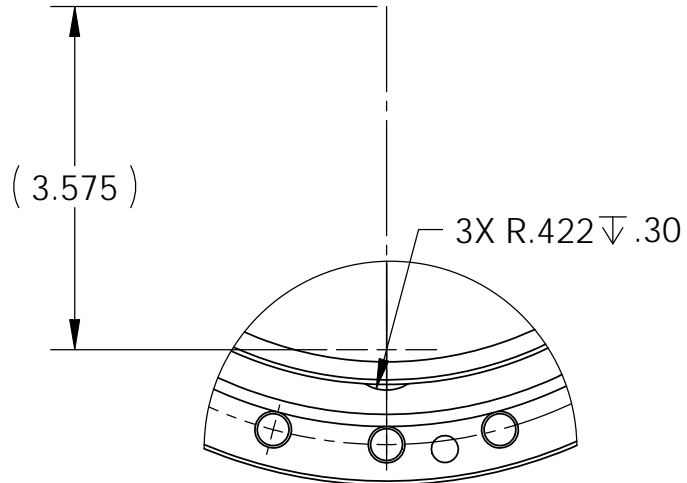

DETAIL B
SCALE 1 : 1

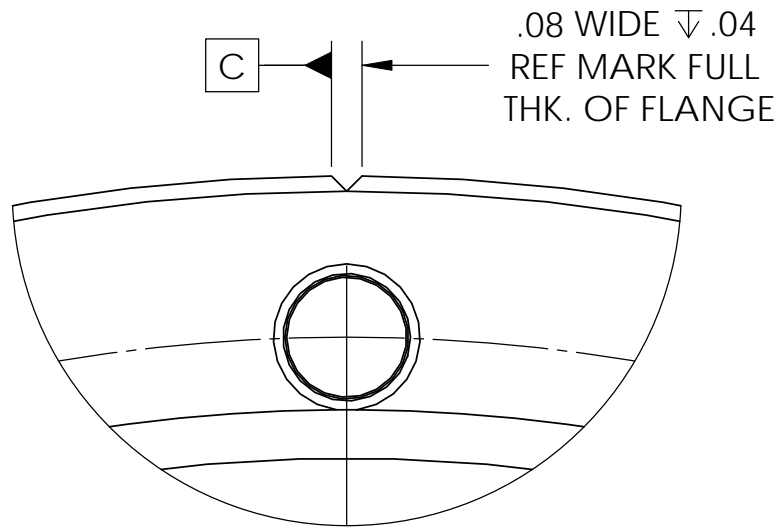
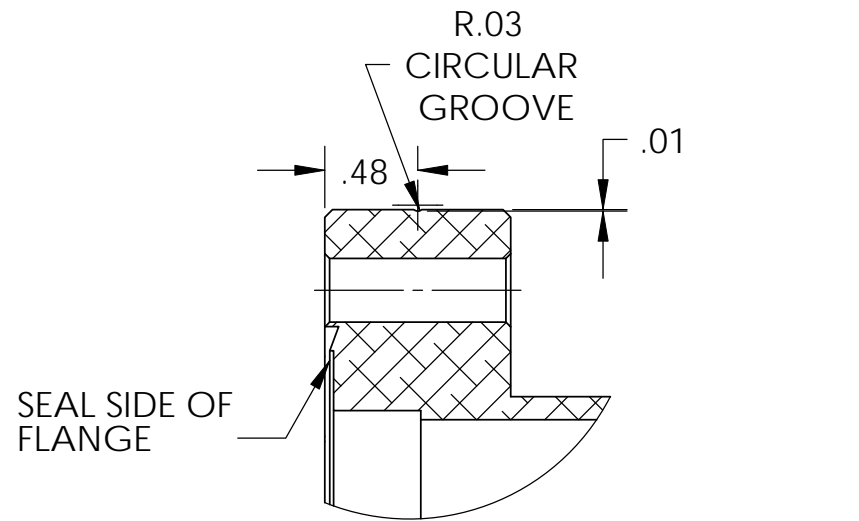

DETAIL E
SCALE 2 : 1

(6X .385)

(6X .050)

6X .065

DO NOT BREAK THRU

.500

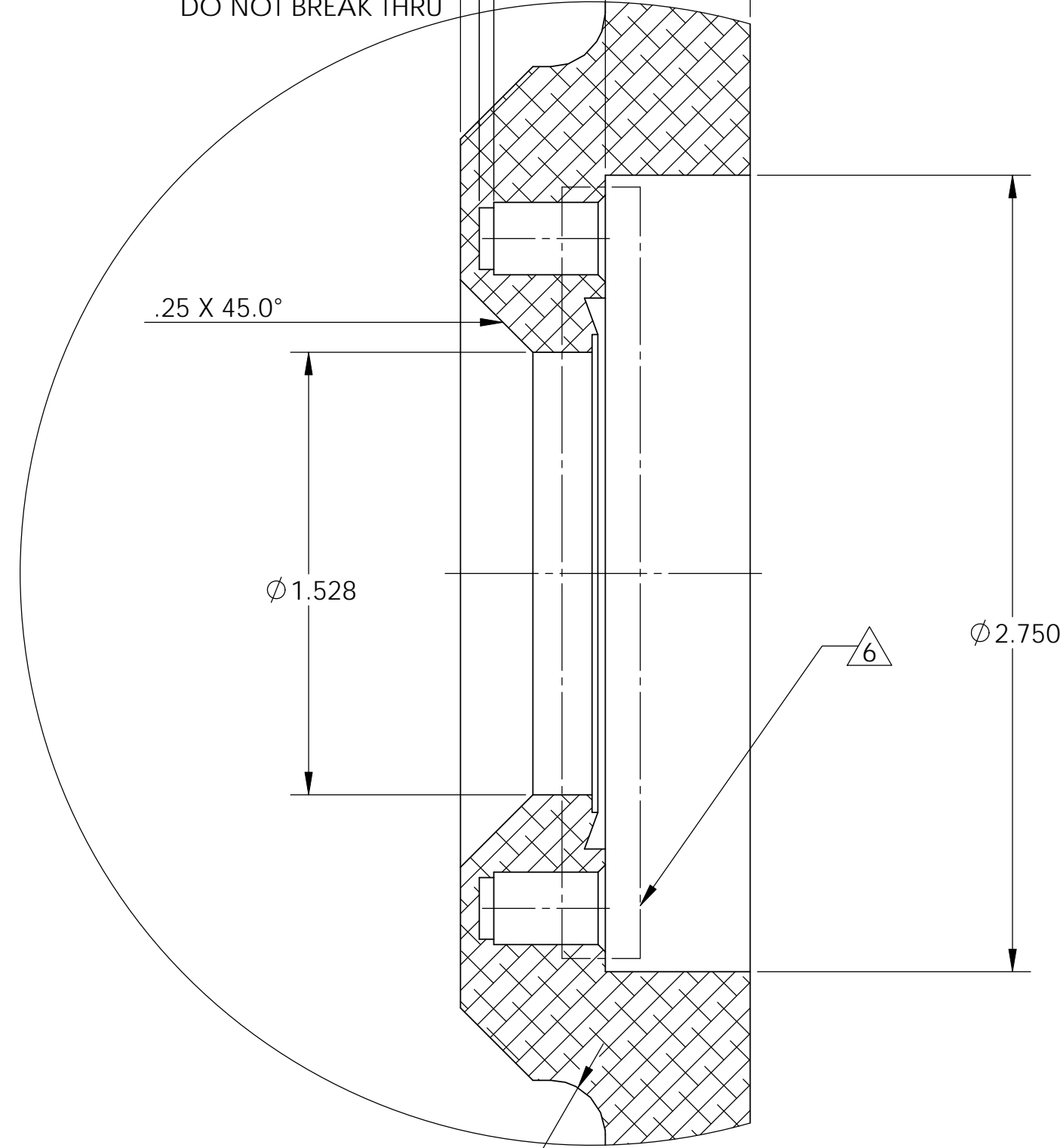

DETAIL C
SCALE 2 : 1

LIGO CALIFORNIA INSTITUTE OF TECHNOLOGY MASSACHUSETTS INSTITUTE OF TECHNOLOGY	
SIZE B	DWG. NO. D0900859
SCALE: 1:4	PROJECTION: SHEET 2 OF 2
REV. V3	