

LIGO Laboratory / LIGO Scientific Collaboration

LIGO-T0900230-V1 **Advanced LIGO UK** 6 May 2009

Quad TOP Coil Drive Unit Test Plan

R. M. Cutler, University of Birmingham

Distribution of this document:
Inform `aligo_sus`

This is an internal working note
of the Advanced LIGO Project, prepared by members of the UK team.

Institute for Gravitational Research
University of Glasgow
Phone +44 (0) 141 330 5884
Fax +44 (0) 141 330 6833
E-mail k.strain@physics.gla.ac.uk
Engineering Department
CCLRC Rutherford Appleton Laboratory
Phone +44 (0) 1235 445 297
Fax +44 (0) 1235 445 843
E-mail J.Greenhalgh@rl.ac.uk

School of Physics and Astronomy
University of Birmingham
Phone +44 (0) 121 414 6447
Fax +44 (0) 121 414 3722
E-mail av@star.sr.bham.ac.uk
Department of Physics
University of Strathclyde
Phone +44 (0) 1411 548 3360
Fax +44 (0) 141 552 2891
E-mail N.Lockerbie@phys.strath.ac.uk

<http://www.ligo.caltech.edu/>

<http://www.physics.gla.ac.uk/igr/sus/>

<http://www.sr.bham.ac.uk/research/gravity/rh,d,2.html>

http://www.eng-external.rl.ac.uk/advligo/papers_public/ALUK_Homepage.htm

QUAD TOP DRIVER COMPLETED UNIT TEST PLAN

Unit.....Serial No

Test Engineer

Date

Drive Card ID.....

Monitor Card ID

Contents

1. Description
2. Test Equipment
3. Inspection
4. Continuity and Isolation Checks
5. Test Set Up
6. Power
7. Relay operation
8. Current Monitor Tests
9. Voltage Monitor Tests
10. Corner Frequency Tests
11. Distortion
12. Full Load Test
13. Noise Monitor Tests
14. Full Current tests
15. Final Assembly

1. Description

The TOP Driver Unit will be used to control the mirror position in the Advanced LIGO Gravity wave experiment.

It controls the current in the coil which provides the magnetic force which controls the position of the TOP mirror in a Quad assembly. It works in conjunction with the OSEM coil and position sensor units. One TOP unit controls four OSEMs.

The TOP Coil Drive Unit contains a Coil Drive board and a Monitor board. The Monitor Board monitors the Output voltage, Output Current, RMS Current and Output Noise from the unit.

The TOP Driver Unit also passes the amplified signals from the Photodiodes, which detect the position of the TOP mirror, back to the control electronics without processing them in any way.

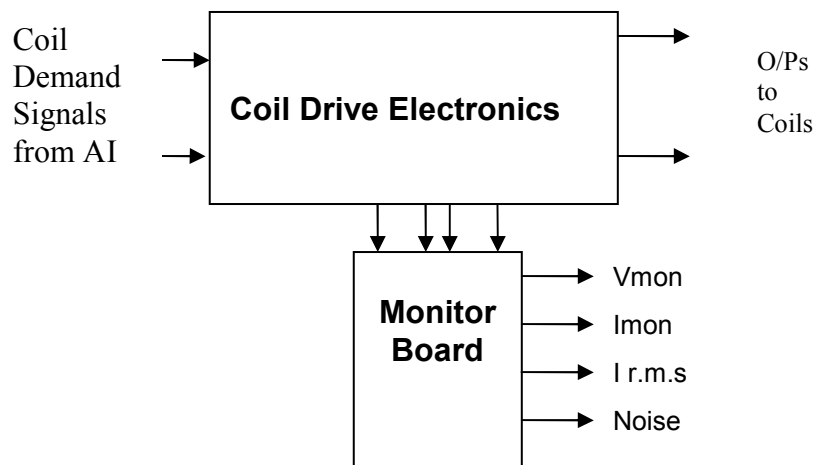

FIG. 1 TOP Driver Unit Block Diagram

Each TOP Driver Unit consists of four identical differential coil drive channels. It also contains the monitor board which monitors the output voltage, current, r.m.s current and noise from each channel

Unit.....Serial No
Test Engineer
Date

2. Test Equipment

- Power supplies (At least +/- 20v variable, 1A)
- Signal generator (capable of delivering 10v peak, 0.1Hz to 10 KHz)
- Digital oscilloscope
- Analogue oscilloscope
- Agilent Dynamic Signal Analyser (or similar)
- Low noise Balanced Driver circuit
- Relay test box

Record the Models and serial numbers of the test equipment used below.

Unit (e.g. DVM)	Manufacturer	Model	Serial Number

Unit.....Serial No
Test Engineer
Date

3. Inspection

Remove the lid of the case.

Workmanship

Inspect the general workmanship standard and comment:

Unit.....Serial No

Test Engineer

Date

4. Continuity Checks

Use a multi-meter to check the connections below.

Photodiode outputs

Pd Out to AA	SIGNAL	DESCRIPTION	Pd in from Sat	OK?
1	PD1P	Photodiode A+	1	
2	PD2P	Photodiode B+	2	
3	PD3P	Photodiode C+	3	
4	PD4P	Photodiode D+	4	
5	0V			
6	PD1N	Photodiode A-	14	
7	PD2N	Photodiode B-	15	
8	PD3N	Photodiode C-	16	
9	PD4N	Photodiode D-	17	

LED Monitors

LED Mon	SIGNAL	Monitors:	In from Sat	OK?
1	Imon1P	Current Source 1+	5	
2	Imon2P	Current Source 2+	6	
3	Imon3P	Current Source 3+	7	
4	Imon4P	Current Source 4+	8	
5	0V			
6	Imon1N	Current Source 1-	18	
7	Imon2N	Current Source 2-	19	
8	Imon3N	Current Source 3-	20	
9	Imon4N	Current Source 4-	21	

Power Supply to Satellite box

In from Sat	SIGNAL	DESCRIPTION	DC in Connector	OK?
9	V+	+17v Supply	A1	
10	V+	+17v Supply	A1	
11	V-	-17v Supply	A3	
12	V-	-17v Supply	A3	
13	0V	Return	A2	
22	0V	Return	A2	
23	0V	Return	A2	
24	0V	Return	A2	
25	0V	Return	A2	

Unit.....Serial No
Test Engineer
Date

Isolation Checks

Check that the driver ICs IC11 and IC12 are isolated from chassis on all channels. Apply a DVM on ohms range and measure the resistance between each transistor tab and the chassis.

IC Tab	Resistance	OK?
IC11 Channel 1		
IC12 Channel 1		
IC11 Channel 2		
IC12 Channel 2		
IC11 Channel 3		
IC12 Channel 3		
IC11 Channel 4		
IC12 Channel 4		

5. TEST SET UP

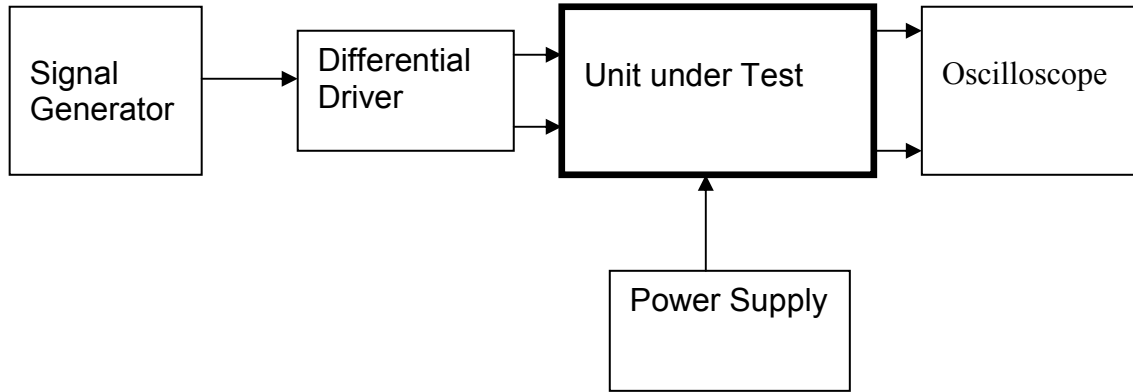

Note:

(1) Input signal to differential amplifier is generally stated in the tests below. There is therefore an inherent gain of 2 in the system.

(2) Some signal generators will indicate 1vpk/pk when the output is in fact 1v Peak into the high impedance Differential driver used. The test procedure refers to the actual voltage out of the signal generator.

Connections:

Differential signal inputs to the Drive Input of the unit under test:

Drive Input pins 1, 2, 3, 4 = positive input

Drive Input pins 6, 7, 8, 9 = negative input

Drive Input pin 5 = ground

Power (depending on connector availability)

Pd In from Sat pin 9, 10 = +16.5v

or DC in A1

Pd In from Sat pin 11, 12 = -16.5

or DC in A3

Pd In from Sat pins 22, 23, 24, 25 = 0v

or DC in A2

Coil Drive Outputs

Ch1+ = Coil out to Sat pin 1

Ch1- = Coil out to Sat pin 9

Ch2+ = Coil out to Sat pin 3

Ch2- = Coil out to Sat pin 11

Ch3+ = Coil out to Sat pin 5

Ch3- = Coil out to Sat pin 13

Ch4+ = Coil out to Sat pin 7

Ch4- = Coil out to Sat pin 15

Voltage, Current and R.M.S monitors

1	Voltage Monitor 4
2	Current Monitor 4
3	R.M.S Current 4
4	Voltage Monitor 3
5	Current Monitor 3
6	R.M.S Current 3
7	Voltage Monitor 2
8	Current Monitor 2
9	R.M.S Current 2
10	Voltage Monitor 1
11	Current Monitor 1
12	R.M.S Current 1
13 to 25	0v

Noise Monitor

1	Channel 1 Noise Monitor
2	Channel 2 Noise Monitor
3	Channel 3 Noise Monitor
4	Channel 4 Noise Monitor
5 to 9	0v

Unit.....Serial No
 Test Engineer
 Date

6. Power

Check the polarity of the wiring from the 3 Pin Power Connector, to each of the boards. Viewed from the back of the unit:

A1	Left pin	Positive	White wire
A2	Middle pin	RTN	Black wire
A3	Right pin	Negative	Green wire

If this is correct,
 Connect power to the unit
 Set the supplies to 16.5v
 Turn on

Record supply currents:

+ 16.5 supply current (mA)	- 16.5 supply current (mA)

Check that all power LEDs are illuminated.

LEDs	Plus	Minus
Front Panel		
Rear Panel		

If the power supplies are correct, proceed to the next section.

Unit.....Serial No

Test Engineer

Date

7. Relay Operation

Operate each relay in turn.
 Observe its operation. LEDs should illuminate when the relays are operated.

Filter

Channel	Indicator		OK?
	ON	OFF	
Ch1			
Ch2			
Ch3			
Ch4			

TEST SWITCHES

Channel	Indicator		OK?
	ON	OFF	
Ch1			
Ch2			
Ch3			
Ch4			

Unit.....Serial No

Test Engineer

Date

8. Current Monitor tests

The purpose of this test is to perform a functionality test on the current monitor and RMS circuits.

To do this, we need to draw a known current from each coil drive output. This is done by plugging the 39 ohm loads into each output, then adjusting the signal generator until the required voltage appears across each load resistor.

Remove all links W4 and W5.

Plug the power 39 ohm dummy load plug into the coil drive output.

Set the signal generator output to 2.5v at 100Hz.

Connect a scope probe to each end of one of the load resistors. Check that a sine wave of around 2v peak appears across each resistor.

Connect a true r.m.s meter across the channel 4 resistor, and carefully adjust the signal generator to give an r.m.s reading of 1.5 volts.

Record the peak output from each of the current monitors using the true r.m.s dvm, and each of the RMS circuits with the meter set to d.c..

1v across load resistor

Channel	Monitor Connector	Parameter	Theoretical Value (+/- .1v)	Measured Value	Pass/Fail
1	Pin 11	Current Monitor	1v r.m.s		
	Pin 12	RMS Current	1 v dc		
2	Pin 8	Current Monitor	1v r.m.s		
	Pin 9	RMS Current	1 v dc		
3	Pin 5	Current Monitor	1v r.m.s		
	Pin 6	RMS Current	1 v dc		
4	Pin 2	Current Monitor	1v r.m.s		
	Pin 3	RMS Current	1 v dc		

Unit.....Serial No

Test Engineer

Date

9. Voltage Monitor tests

The purpose of this test is to verify and calibrate the Voltage Monitor circuit on each channel.

Switch all filters out. Remove the dummy loads and make differential voltage output measurements on the coil drive outputs at 100 Hz. Adjust the signal generator to give a voltage to 10v on the coil drive outputs.

Record the peak voltage on each Voltage Monitor pin, and check against the theoretical figure.

Channel	Coil Drive Output pins	Voltage Monitor socket Pin	Monitor output?	Expected value	OK?
1	Pins 1,9	Pin 10		3.2v to 3.4v	
2	Pins 3,11	Pin 7		3.2v to 3.4v	
3	Pins 5,13	Pin 4		3.2v to 3.4v	
4	Pins 7, 15	Pin 1		3.2v to 3.4v	

Unit.....Serial No

Test Engineer

Date

10. Corner frequency tests

The purpose of this test is to verify that the frequency response of each filter stage of each channel is correct.

Ensure that links W4 and W5 are present.

Using the Dynamic Signal Analyser

With the filter switched in, measure the frequency response of each channel in turn between 0.1 Hz and 1 KHz. If a fast turn around is required, limit the measurement to the frequency range to between 1 Hz and 1 KHz. Measure the gain at the spot frequencies below and record them.

Connect the 39 ohm loads across each coil output to simulate the coils.

Channel 1

Frequency	Gain (dB)	Expected Gain	Pass/Fail
0.1 Hz			
1Hz			
10Hz			
100Hz			
1KHz			

Channel 2

Frequency	Gain (dB)	Expected Gain	Pass/Fail
0.1 Hz			
1Hz			
10Hz			
100Hz			
1KHz			

Channel 3

Frequency	Gain (dB)	Expected Gain	Pass/Fail
0.1 Hz			
1Hz			
10Hz			
100Hz			
1KHz			

Channel 4

Frequency	Gain (dB)	Expected Gain	Pass/Fail
0.1 Hz			
1Hz			
10Hz			
100Hz			
1KHz			

Unit.....Serial No
 Test Engineer
 Date

11. Distortion

Remove links W4 and W5. Plug in the 5 Watt 39 Ohm dummy loads. Increase input voltage to 10v peak, f = 1KHz. Check the differential voltage across each load for distortion with an analogue oscilloscope.

	Distortion Free?
Ch1	
Ch2	
Ch3	
Ch4	

12. Full Load Test

Apply the DC source to the input to the differential amplifier. Connect the 39 Ohm 5 watt loads to the outputs.

Increase the input voltage to 10v with respect to 0v, and monitor the temperatures of the drive amplifiers. If their temperature increases above 100°C, flag a problem!

Leave running for 10 minutes, then record the temperatures of drive amplifiers, and the differential output voltages from the amplifier (TP9 and TP13).

The output voltages should be recorded.

Output	Voltage	> 24v?	DRIVER	Temperature	<60°C?
CH1 Positive			CH1 IC1		
CH1 Negative			CH1 IC5		
CH2 Positive			CH2 IC1		
CH2 Negative			CH2 IC5		
CH3 Positive			CH3 IC1		
CH3 Negative			CH3 IC5		
CH4 Positive			CH4 IC1		
CH4 Negative			CH4 IC5		

Unit.....Serial No
 Test Engineer
 Date

13. Noise Tests

As the previous test involves non – representative temperature rises, allow the unit to cool before performing this test.

Replace the filter links W4 and W5 on each channel.

Replace the lid of the box, and replace screws.

Connect the filter test box, and switch in all filters.

Switch it out of Test Mode

Use the HP 35670A Dynamic Signal Analyser.

Connect a shorting plug to the demand input to short all positive and negative demands together and to 0v. Connect 39 Ohm loads to the outputs.

Switch the filters in.

Use Stuart Aston’s noise measurement set up, loaded from disc.

Measure the noise output from each channel in turn at the amplifier outputs. The Low Pass filter on the SR650 may be used to reduce mains interference, to prevent the Signal Analyser from overloading. Ideally the filter corner frequency should be set to 3 KHz. Set the amplifier gain to 1000, and check that the overload light is not on before each measurement.

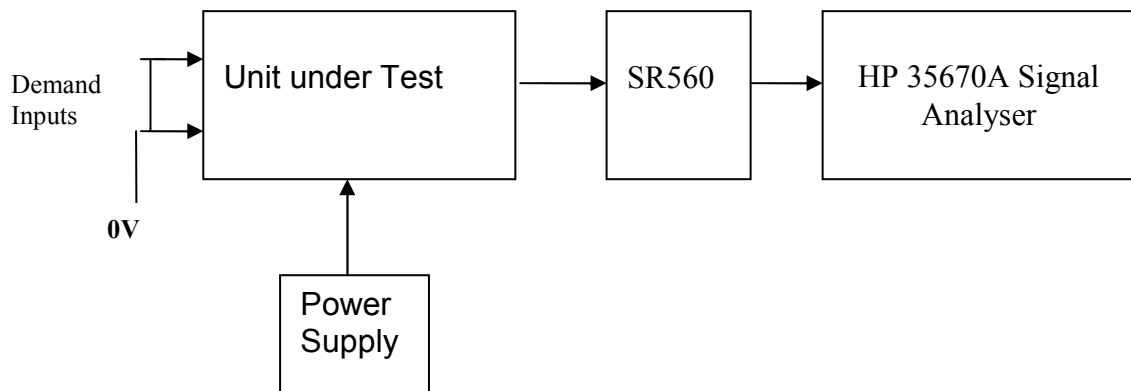

	Spec in dB V/√Hz	Measured @ 10Hz	-60dB =
Ch1	-161.15dB		
Ch2	-161.15dB		
Ch3	-161.15dB		
Ch4	-161.15dB		

Notes:

Specified noise output current at 10 Hz = 73 pA/√Hz

Total output resistance = 120 Ohms

Amplifier noise voltage should therefore = 8.76nV/√Hz or -161.15 dB

The noise monitor amplifier has an internal gain of 42dB at 10Hz. The noise floor is about -133dB.

Unit.....Serial No

Test Engineer

Date

14. Full Current Tests

High power dummy loads are needed for this test.

With the dummy loads removed, measure and record the value of each resistor. Nominal 39 Ohm power resistors should be used.

Plug in the dummy load.

Remove the filter links.

Drive the unit with a 10v peak sine wave on each channel, which should measure 7.07 volts on a true r.m.s meter.

Measure the voltage across each load resistor and record it. Calculate the current through each resistor, and compare with the specification. If a true r.m.s meter is used to make the measurement, compare with the r.m.s specification

Channel	R =	V=	Therefore I =	Spec (peak)	Spec (r.m.s)	Pass?
1				>200mA	>141.4mA	
2				>200mA	>141.4mA	
3				>200mA	>141.4mA	
4				>200mA	>141.4mA	

Unit.....Serial No
Test Engineer
Date

15. Final Assembly Checks

1. Remove the lid of the box.
2. Unplug all external connections.
3. Check that the 9mm pillars are in place in the corners of the Monitor Board towards the centre of the box.
4. Check that all internal connectors are firmly mated.
5. Tighten the screw-locks holding all the external connectors.
6. Check that the nuts holding the tabs of the power drivers are secure – tighten as necessary. Test with a DVM that none of the tabs are shorted to chassis.
7. Check that all the LEDs are nicely centred.
8. Check that links W4 and W5 are in place.
9. Check that the boards are labelled with their Drawing Number, Issue Number, and serial number. Record below:

UoB box ID	
Driver board ID	
Driver board Drawing No/Issue No	
Driver board Serial Number	
Monitor board ID	
Monitor board Drawing No/Issue No	
Monitor board Serial Number	

10. Check the security of any modification wires.
11. Visually inspect.
12. Put the lid on and fasten all screws,
Check all external screws for tightness.