

LASER INTERFEROMETER GRAVITATIONAL WAVE OBSERVATORY
- LIGO -
CALIFORNIA INSTITUTE OF TECHNOLOGY
MASSACHUSETTS INSTITUTE OF TECHNOLOGY

Specification	LIGO-E960022-05 - E	02-23-99
LIGO Vacuum Compatibility, Cleaning Methods and Qualification Procedures		
LIGO Systems Engineering		

This is an internal working note
of the LIGO Project..

California Institute of Technology
LIGO Project - MS 51-33
Pasadena CA 91125
Phone 626.395.2129
Fax 626.304.9834
E-mail: info@ligo.caltech.edu

Massachusetts Institute of Technology
LIGO Project - MS 20B-145
Cambridge, MA 01239
Phone 617.253.4824
Fax 617.253.7014
E-mail: info@ligo.mit.edu

WWW: <http://www.ligo.caltech.edu>

CHANGE RECORD

<i>Revision</i>	<i>Date</i>	<i>Authority</i>	<i>Pages Affected</i>	<i>Item(s) Affected</i>
A	25 March 1998	Initial release	All	All

<i>Organization/Group</i>	<i>Name</i>	<i>Signature</i>	<i>Date</i>
Systems Engineering and Chair, LIGO Vacuum Review Board	Albert Lazzarini		
LIGO Vacuum Standards Board	Jordan Camp		
	Fred Raab		
	David Shoemaker		
	Rainer Weiss		
	John Worden		
Project Manager	Gary Sanders		

TABLE OF CONTENTS

1	Scope.....	5
1.1.	Purpose.....	5
1.2.	Content.....	5
1.3.	Vacuum Standards Board	5
2	Applicable Documents.....	6
3	Vacuum Compatible Material Usage in LIGO	6
3.1.	Material Approval Process.....	6
3.2.	Component Qualification.....	7
4	Cleaning and Preparation of Materials Procedures.....	7
4.1.	Commercially Produced Components	8
4.2.	Internally Produced Components.....	8
5	Handling and Storage Procedures.....	9
6	Qualification and Screening Tests for Materials and Components	10
6.1.	Initial Qualification & Screening.....	11
6.1.1.	High Power Exposure Tests of Cavity Mirrors.....	11
6.1.2.	Outgassing Screening Tests	12
6.1.2.1	Bake out	12
6.1.2.1.1	Vacuum Bake.....	12
6.1.2.1.2	Air Bake	14
6.1.2.2	Residual Gas Analysis	14
6.2.	QA Screening.....	14
A	Appendix - Cleaning procedures for approved and provisionally approved materials.....	15
B	Appendix - Forms.....	19
C	Appendix -- Calculation of Vacuum Load.....	21

LIST OF FIGURES

Figure 1:	Exposure Test Setup.....	12
Figure 2:	Typical Vacuum Bake Test Set.....	13
Figure 3:	Geometrical arrangement of source, mirror, and pumping system	23
Figure 4:	Schematic for the calculation. A substance that outgasses a condensible material has a surface area A_s , in the figure located in a sidearm of the system, though this is not essential to the model. The surface of the system initially has no surface loading of this material. The question is how to estimate the surface loading of the system as a function of time. ²⁷	
Figure 5:	Relation between the surface coverage and the equilibrium pressure for the Dubinin - Radushkevich theory ²⁹	

LIST OF TABLES

Table 1: Applicable Documents.....6
Table 2: Parameters for estimating contaminant buildup on LIGO optics22
Table 3: Physical constants23
Table 4: Typical values for water on hot rolled 304L stainless steel.....28
Table 5: Sample parameters leading to 200 day equilibration time.....29

NOMENCLATURE AND ACRONYMS

ADP	Ammonium Di-hydrogen Phosphate [(NH ₄)H ₂ PO ₄]
AMU	Atomic Mass Unit
HC	Hydrocarbons
HF	Hydrofluoric acid
JPL	Jet Propulsion Laboratory
KDP	Potassium Di-hydrogen Phosphate [KH ₂ PO ₄]
LIGO	Laser Interferometer Gravitational Wave Observatory
OFHC	Oxygen Free High-Conductivity Copper
NEO	Neodymium Iron Boron
PFA	Perfluoroalkoxy fluoropolymer (Du Pont)
PTFE	Polytetrafluorethylene (Du Pont)
PZT	Lead-Zirconate-Titanate
RGA	Residual Gas Analyzer
RTV	Room Temperature Vulcanizing Silicone elastomer
TBD	To Be Determined
UHV	Ultra High Vacuum

1 Scope

1.1. Purpose

The goal of this document is to provide reasonable assurance against the inadvertent introduction into the LIGO vacuum envelope of material which could contaminate optics and/or produce excess phase noise by forward scattering.

This document sets forth certain procedures and standards by which material to be used in LIGO interferometers may be qualified and assayed for compatibility in operation with high-power resonant cavities inside an ultra-high vacuum (UHV) system.

All items to be installed inside LIGO vacuum equipment or onto beam tube pump ports shall conform to this policy for selection of components and exposed materials, for preparation, handling, testing and storage prior to assembly and during assembly

It is intended that the total optical contamination produced by detector components placed into the LIGO vacuum envelope shall be limited to < 0.5 ppm/yr/optic absorption and < 10 ppm/yr/optic scatter.

1.2. Content

All materials/parts (commercial and custom designed) must undergo vacuum outgassing and contamination evaluation to ensure compatibility with operation in high-power laser cavities within ultra-high vacuum systems.

Certain materials needed to fabricate LIGO interferometers, although used in other UHV applications, need to be evaluated for possible deleterious effects which their outgassing products may produce on high reflectivity mirrors while these mirrors are under laser irradiation at power levels of tens of kW. A determination of the rate of increase of optical losses by exposure of test cavity mirrors to substances in question shall be the basis for vacuum qualification whenever possible for such substances.

It is also necessary to ensure proper cleaning of components fabricated from acceptable materials. Cleaning of LIGO components shall be performed in accordance with recognized and accepted cleaning practices. Some of these cleaning procedures are generic and baking will be carried out generally at the maximum temperature permissible for a given material: other procedures have been developed to handle specialized or oversized components that could otherwise not be cleaned.

1.3. Vacuum Standards Board

Outgassing data and, whenever possible or necessary, optical loss data of materials/parts shall be submitted to the Vacuum Standards Board for review and acceptance. The Vacuum Standards Board must approve tested materials/parts before they may be included in the LIGO vacuum compatible materials approved list (E960050). The Vacuum Standards Board members are selected by the Systems Engineering and the Detector Systems group management.

The Vacuum Standards Board will recommend the disposition of issues where policy and schedule are in conflict. This document will be updated as irradiance exposure data become available.

2 Applicable Documents

The documents cited in Table 2-1 have been used to develop some of these guidelines and serve as reference material.

Table 1: Applicable Documents

DOCUMENT TITLE	DATE AND ID NUMBER
LIGO Project Management Plan	LIGO-M950001
LIGO Project System Safety Plan	LIGO-M950046
LIGO Project QA Plan	LIGO-M970076
LIGO Configuration Management Plan	LIGO-M950005
LIGO Vacuum Compatible Materials List	LIGO-E960050
Stanford Synchrotron Radiation Project User Specifications for Vacuum Systems and Components Which Interface with the SPEAR Vacuum System	SLAC-TN-73-13 October 1973
Detail Specification for General Cleaning Requirements for Spacecraft Propulsion Systems and Support Equipment	JPL-FS504574 28 May 1974
LIGO Seismic Isolation System: Fabrication Process Specification	E970063
Material, Process, Handling and Shipping Specification for Fluorel Parts	E970130
Material, Process, Handling and Shipping Specification for Welded Diaphragm Bellows	E970129
Material, Process, Handling and Shipping Specification for Damped Coil Springs	E970131
Specification for the LIGO Bakeout Ovens	T980008

3 Vacuum Compatible Material Usage in LIGO

3.1. Material Approval Process

LIGO maintains an updated list of materials considered safe to use in LIGO vacuum systems. This approved list is LIGO-E960050. New material must go through the prescribed screening process before it may be added to this list. The screening process is described in Section 6 of this document. The vacuum data of the tested materials/parts will be compared to the LIGO vacuum outgassing and contamination requirements before being included in the LIGO vacuum compatible materials approved list.

In cases where any of the cleaning procedures cannot be followed due to considerations such as material durability or sensitivity to elevated temperatures, a waiver shall be completed and submitted to the Vacuum Board for consideration and approval. The waiver shall be accompanied by an alternative preparation procedure which has been demonstrated to achieve the desired cleaning effects.

3.2. Component Qualification

- A component or subassembly is itself considered approved if all its exposed materials are approved and if its pre-installation treatment is consistent with the preparation procedures for those materials.
- All blind holes and trapped volumes shall be explicitly vented to avoid virtual leaks; provision for cleaning such volumes adequately (e.g., by solvent flushing) shall also be considered in the design process.
- A material is considered "exposed" unless it is encapsulated fully and hermetically within another material. All designs using hermetic containment must be approved specifically by the Vacuum Standards Board.
- Components composed of materials from a single class are to be prepared, handled and stored according to the corresponding procedure for that class.
- Irreducible subassemblies comprising more than one material class are to be prepared and handled according to the most stringent subset of procedures consistent with all materials involved.
- A Qualification and Screening Test Report must be written for the candidate material/ component after completion of tests. This report must include the amounts of materials, outgassing rates (approved or not), residual gas analyses and RGA scan data, molecular species that is outgassed, amount of hydrocarbons outgassing, and surface contamination information if available. A material usage list must be compiled for every subassembly or component that is placed in the vacuum and be included in the report. This information shall be available by the FDR of the subject system or subsystem. The material usage list for each assembly shall be updated to maintain it current.
- The Qualification and Screening Test Report and associated raw data (e.g., RGA scans) shall be processed as follows:
 - File original with the LIGO QA Officer
 - Submit copy to the requester of the qualification tests
 - Submit a copy to the LIGO Document Control Center.

4 Cleaning and Preparation of Materials Procedures

All materials/parts (both commercial and LIGO-produced) must be scrutinized for vacuum cleanliness compatibility before being accepted for utilization with the LIGO vacuum system.

4.1. Commercially Produced Components

If a vendor is required to provide clean components, then the vendor shall use recognized UHV practices. The vendor shall submit to LIGO a description of the practices for prior approval by LIGO as part of the quote or proposal for the work in accordance with the procurement process.

For commercially produced components with potentially many materials used in the construction, a detailed accounting of all materials and the amounts used shall be submitted for review. It may be necessary for some components to require certifications (per article or serial number) for the materials employed in their manufacture, so that material substitutions by the manufacturer are visible to LIGO. The vendor shall notify LIGO of any material substitutions which occur after the agreed-upon list of materials has been determined. LIGO QA shall have oversight to ensure such notification is obtained. Where practicable, a first article screening using an RGA scan and outgassing measurement shall be performed by LIGO prior to receiving shipment of all other components.

4.2. Internally Produced Components

LIGO shall clean in accordance with documented procedures all components produced internally. Cleaning procedures shall be defined for all materials on the LIGO approved materials list. Present procedures are listed in Appendix A. These will updated periodically. The LIGO approved materials list includes:

Generic materials:

- Metals
- Ceramics and glasses
- Hard crystalline minerals, excluding electro-optical elements

Fabricated materials:

- LIGO optical components
- Composite Assemblies
- Commercially purchased mechanical assemblies
- Electronic Components
- Suspension Sensor/Actuator Head assemblies

There are also provisionally approved materials being used in prototype interferometers. It is permissible to incorporate provisionally accepted materials in LIGO interferometer designs; however before the designs may be actually implemented, promotion of their constituent materials to the accepted materials list must be performed in accordance with the procedures set forth in this document. Provisionally approved materials list includes:

- Viton

- Silicone rubber (see notes in Appendix A, item F)
- Teflon
- Solder, type TBD (see also Appendix A, item H)
- Sm-Co permanent magnets
- PZT piezoelectric ceramics
- Hygroscopic crystalline optics

5 Handling and Storage Procedures

Cotton gloves over Nitrilite¹ gloves are to be worn for handling, assembly and installation of cleaned or partially cleaned parts. Unless otherwise indicated, both sets of gloves are to be changed when proceeding to handle components at different stages of processing.

Tools and fixtures which may contact cleaned parts in assembly or transport are to be cleaned ultrasonically in Alconox solution and/or methanol (consistent with their construction) and air-dried.

Processed parts awaiting installation or further assembly will be triple wrapped for storage or shipping as follows:

- (a) wrap the part(s) with UHV quality aluminum foil
- (b) Place each part(s) in an anti-static bag fabricated from "CP Stat 100(TM) ESD poly sheet cleaned to Class 100"
- (c) Evacuate and back fill the bag with 0.1 micron filtered dry nitrogen.
- (d) Compress the bag tightly around the part(s) to purge excess nitrogen. Tie wrap the bag for closure, or use a bag with a zipper.
- (e) Place the part(s) in a second anti-static polyethylene bag, as specified above, remove excess air, purge with dry nitrogen and heat seal shut, making sure both labels are visible. Two labels must be used on the outer layer of all bagged components: (i) a warning label stating: "UHV CLEAN PART -- HANDLE ONLY WITH PROPERLY GLOVED HANDS" and (ii) an identification label. If the labels are not self-adhesive, then they shall be affixed with tape. All empty fields on the ID label shall be filled in with the relevant information; use "N/A" rather than leaving a field blank.
- (f) Place the double bagged part(s) in an appropriate shipping container, using care to not puncture or cut the bags. Seal the shipping container closed. Attach a label with the LIGO part

1. Nitrilite 100% nitrile gloves from Ansell Edmont Industrial. Nitrilite gloves have been found to have a surface surfactant/lubricant which has been suspected of transferring to cleaned parts. Nitrilite gloves must be rinsed before first use. In addition take the precaution of using an outer *non-shedding* cotton glove over the nitrilite.

number (drawing number(s), including revision letter) and serial number(s) to the outside of the container.

The shipping containers must be such that they insure that the double bags do not get punctured and that the parts are properly supported during transit.

The CP Stat material is ordered as follows:

CP Stat 100 ESD sheeting cleaned to Class 100 with CFC certification that it passes JPL specifications. At the time of this writing, it is available in various sheet and bag sizes from:

Caltex Plastics, Inc.
P.O. Box 58546
2380 E. 51st Street
Vernon, CA 90058
(213) 583-4140

At the time of this writing, one source for UHV Quality Aluminum Foil is:

ASTM B-479 Dry Annealed A Allfoil
4597 Vanepps Rd.
Brooklyn, OH 44131
(216) 661-0211

Small parts may also be stored in stainless steel or glass containers which are cleaned and prepared in the same way as vacuum equipment.

Tables and work areas for cleaning, packing/unpacking, assembly, alignment and testing of cleaned parts are to be lined or covered with fresh contamination-free foil or film immediately before starting work. Plastic film shall not be used if an solvent incompatible with the film is involved in the assembly or cleaning process. Final assembly of any small subassembly or component intended for installation in LIGO shall be assembled under a Class 100 laminar flow bench. Assemblies too large for handling on laminar flow benches shall be unwrapped and assembled in portable clean rooms assembled around open chambers.

6 Qualification and Screening Tests for Materials and Components

Tracking and control of material usage in LIGO has two aspects:

- Initial determination that a particular material (or component assembly if it cannot be disassembled) is benign with regard to its effect on optical surfaces and interferometer excess phase noise caused by forward scattering. This shall be done by exposing mirror surfaces in test resonant cavities with resonant optical power representative of the worst-case LIGO irradiances. A corroborating RGA scan of the material shall be recorded in order to develop a

- database containing both optical effects and related outgassing measurements.
- QA screening of components fabricated from approved materials. The basis of such screening shall be the measurement of hydrocarbon outgassing of the subject components using RGA scans after appropriate vacuum preparation. The RGA levels for a pre-determined and specified group of species masses which represent hydrocarbon fragments shall be compared to those obtained in the material qualification step. Excess RGA levels shall indicate inadequate cleaning and preparation of the component under test. Reliance on RGA scans for screening is required to provide a faster process to accommodate fabrication schedules.

6.1. Initial Qualification & Screening

All candidate materials must satisfy the criterion of screening and qualification testing before being considered for addition to the vacuum compatible “approved” or “provisionally approved” list. The distinction between approved and provisionally approved materials lies at present with lack of definitive data for provisional materials about their behavior in mirror cavities at LIGO irradiance levels.

The high power exposure (qualification) test of cavity mirrors and screening test are described in detail in the following paragraphs. Materials which are intrinsically free of organic compounds (after suitable cleaning) may be excluded from laser cavity testing.

6.1.1. High Power Exposure Tests of Cavity Mirrors

The purpose of the exposure test is to evaluate the candidate material for optical contamination potential under high laser power in the presence of high reflectance mirrors. Outgassing can lead to contamination of the optics with the result of increased optical losses and ultimately failure due to heating. The amount of outgassing is less important than the molecular species that is outgassed. There are two test procedures in the exposure test, which are briefly described below; a complete procedure shall be developed. Efforts to date have been directed at developing comparison tests between empty cavities and cavities exposed to candidate materials. A typical cavity setup is shown in Figure 1.

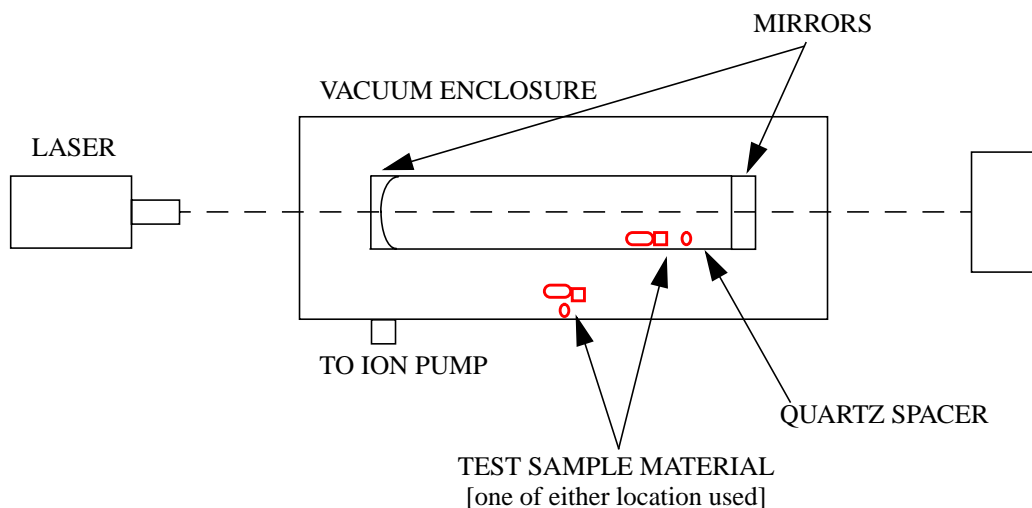
Figure 1: Exposure Test Setup

The qualification procedure includes the following steps:

- Vacuum bake candidate materials according to the procedure for that material, then cool and take an RGA scan to quantify the outgassing. The scan must be calibrated against one or more standard leaks.
- Run an optical exposure test at $\Phi > 150 \text{ kW/cm}^2$ in a resonant cavity to qualify material at the level of optical losses discussed in Section 1.1. The run shall be the shorter of 2 months or when a measurable effect is observed.
- If the candidate material is deemed safe for incorporation into LIGO designs, then subsequent components made of this material shall be screened in the manner described below.

6.1.2. Outgassing Screening Tests

There are two steps of the screening test:

1. a bakeout for driving volatile substances (HCs) off the component;
2. a residual gas analysis (RGA).

6.1.2.1 Bake out

The default bakeout procedure shall be conducted under vacuum. However, it is expected that there will be large components which it may not be feasible to bake under vacuum. In these cases, an air bake will be considered acceptable providing cautions are taken to preclude contamination from the ambient air.

All bakes shall be performed in LIGO-approved ovens; these may be located at vendors.

6.1.2.1.1 Vacuum Bake

Vacuum baking of the candidate component/material is performed to obtain hydrocarbon and

other outgassing data information. The typical vacuum bake test setup is shown in Figure 2.

Figure 2: Typical Vacuum Bake Test Set

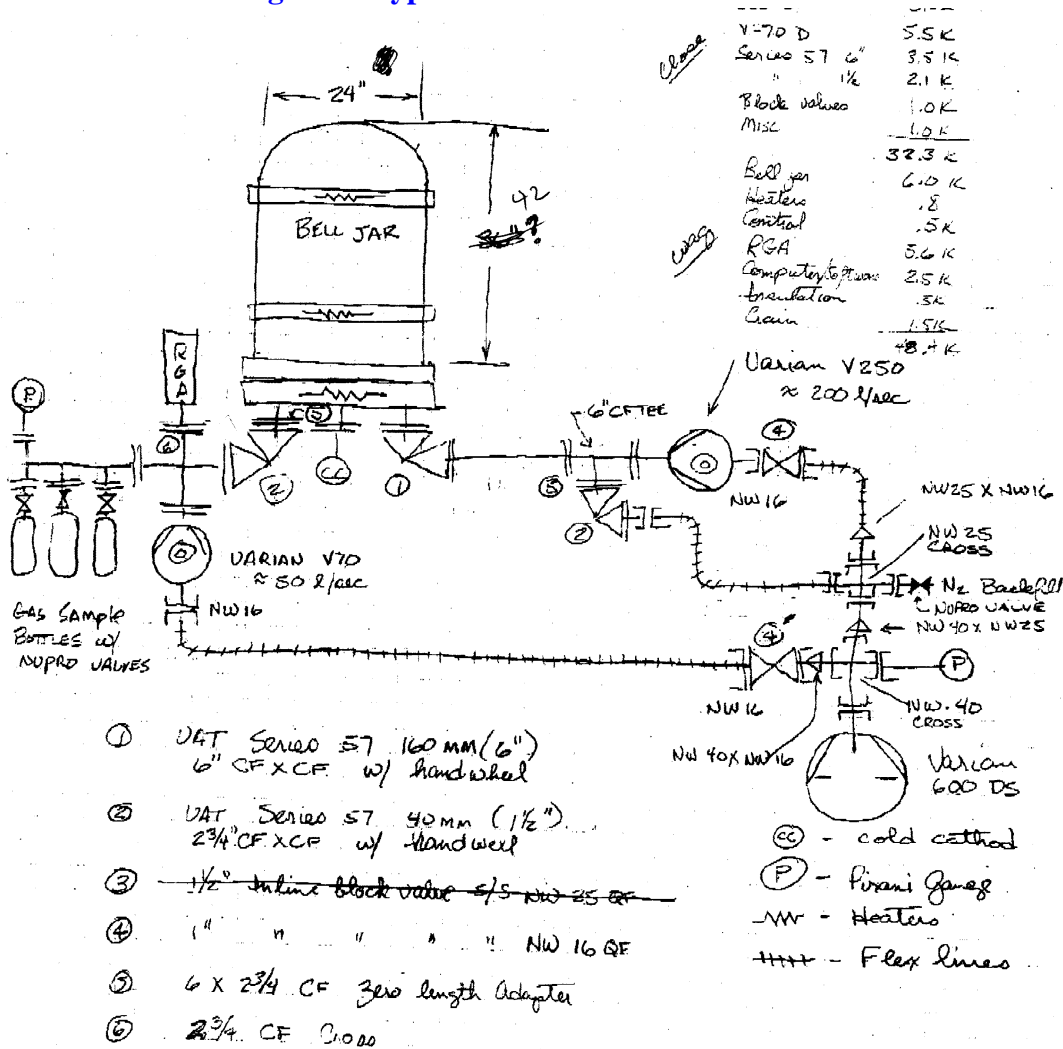

Typical testing procedures are:

- Obtain sample of candidate component/material to be tested
- Obtain a "Parts Cleaning Request" (see Appendix B Form B1) form from Detector Systems for pre-bake cleaning. Follow the cleaning methods and handling procedures in Sections 4 and 5 above according to the type of material, and indicate the procedures on the form.
- Obtain a "LIGO vacuum bake oven procedure and check list" (see Appendix B Form B2) from Detector Systems. Provide the component/material baking time and temperature and any requirements for temperature ramptime or soaktime. Baking temperatures shall follow written procedures discussed in Sections 4 and 5.

- Perform a system calibration according to the defined procedure.
- Perform a vacuum bake of candidate component/material

At the end of the vacuum bake period, obtain a record of the partial pressures of suspect HC masses to document results.

6.1.2.1.2 *Air Bake*

The air bake procedure for large in-vacuum components which cannot be handled otherwise is set forth in E970063, LIGO Seismic Isolation System: Fabrication Process Specification. it applies to all similar components in LIGO.

6.1.2.2 **Residual Gas Analysis**

Cleaning and baking of components/materials must be followed by a residual gas analysis. This analysis shall be performed and documented according to LIGO defined procedures.

6.2. **QA Screening**

All components fabricated from approved materials and which are intended for installation into the LIGO vacuum envelope shall be screened to ensure that proper preparation of the subject components has been achieved. This screening follows the procedure outlined in Section 6.1.2, Outgassing Screening Tests.

In cases where a large number of components are to be screened, it may be permissible to perform a statistical sampling of components instead of 100% testing. However in this case, it must be assured that the results of the screening test for the sampled article are determined to be acceptable before *any* intervening untested articles are integrated into LIGO. In this way a screening failure can be tracked to all potentially affected articles. The sampling frequency shall be submitted for approval by Detector to the Vacuum Review Board.

In the event that a component fails the screening test, it must either be re-processed or if there are sufficient reasons, a request must be made of the Vacuum Review Board for a waiver. In the case of a screening test failure with statistical sample, it must be assumed that all intervening untested articles are also suspect and must thus be reprocessed unless it can be shown that the reason for failure is specific to the failed article.

A Appendix - Cleaning procedures for approved and provisionally approved materials

Approved Materials

These procedures are consistent with:

- 1) a materials bakeout at the maximum temperature possible
- 2) achievement of the summed mass pressure limit

Any deviation from these procedures must be cleared with the Vacuum Policy Board with an approved waiver. Ultrasonic cleaning shall be done in a unit comparable to the system presently in use at MIT.¹

A. Metals:

- For all small metal parts do the following:
 - Machine all sides
 - Ultrasonic clean in Liquinox² for 10 minutes
 - Rinse in distilled water at least 3 times, changing the rinse water every time.
 - Ultrasonic clean in methanol³ for 10 minutes.
 - Subsequent to the above steps bake the metal as follows:
 - Stainless Steel
 - Bake in vacuum at 200 C° for 48 hours.
 - Aluminum
 - Bake in vacuum at 120 C° for 48 hours.
 - SEI damped springs shall be cleaned per the procedure outlined in E970131.
 - SEI large in-vacuum components shall be cleaned per the procedure outlined in E970063
- NOTES: - In the case of gross contaminants, the above may be preceded by an acid bath (i.e., 3% Protex solution (diluted with distilled water) for aluminum or 2% Gosh solution for stainless steel), or an appropriate degreasing agent such as trichloroethane or acetone. Follow these steps with a DI water rinse. Then clean as in A.

Nylon scouring pads must be used only when absolutely necessary and sparingly followed with a vigorous DI rinse. Stainless steel brushes and pads are preferred. Cotton swabs, wetted with methanol, must be used after cleaning blind holes to test for cleanliness.

- Solvents must be reagent grade.

-
1. Branson Ultrasonics Corp. (Tel: +1.203.796.0400) Model 8210(latest model as of March, 1998: #8510) has a 5.5 gal. tank (19.5"x18"x6"). Transducer output is 320 watts @ 40khz. The tank can also be heated.
 2. Standard Liquinox solution is 1 tablespoon in 1 gallon of water.
 3. Methanol is the preferred solvent. Isopropanol and/or acetone may be substituted.

- B. Ceramics and Glasses:
- Clean off contaminants with soap and water or trichloroethane, be sure to rinse thoroughly
 - Ultrasonic clean in methanol for 10 minutes
 - Soak in isopropyl alcohol for 10 minutes, agitating regularly
 - Bake in a vacuum at 120 C° for 48 hours.
- C. LIGO optical components -
Clean Ligo optical components according to Process Specification E990034-00-D and/or E990035-00-D.
- D. Compound Assemblies
- D1. Commercial Stages:
- Disassemble and clean parts in ultrasonic cleaner with Alconox for 10 minutes
 - Rinse in clean water
 - Clean in ultrasonic cleaner with methanol for 10 minutes
 - Replace all plastic parts with appropriate metal or Teflon replacement part (Teflon PFA 440 HP pieces)
 - Remove Teflon parts and clean thoroughly
 - Use Krytox grease sparingly on surfaces that absolutely require lubrication
 - Reassemble stages
 - Bake in vacuum at 120 C° for 24 hours.
- D2. Electronic Components:
- Clean with detergent and rinse
 - Bake in vacuum at highest temperature compatible with manufacturer's maximum rating.
- D3. Sensor/Actuator Head assemblies:
- Ultrasonic clean in methanol for 10 minutes
 - Soak in isopropyl alcohol for 10 minutes agitating regularly
 - Bake in vacuum at 80 C° for 48 hours.

Provisionally Approved Materials (3/1998)

- E. Fluorel (Viton):
Seals and O-rings:
- Wipe with clean, dry tissue.
 - Bake in vacuum for 48 hours at 120 degrees C.
 - At least 24 hours prior to installation, rinse all fluorel seals and O- rings under running DI water. Direct the water over all surfaces ensuring that they thoroughly wetted for at least 30 seconds. A possible method might be to string a number of them like donuts on a rod suspended over a sink so the water can be directed over a number of O-rings simultaneously.
- If possible, blow them dry using particulate filtered nitrogen, turning as required to reach any trapped surfaces. Then allow to further dry in a clean area overnight.
- Wrap for transport to the installation.

Molded castings:

- Follow procedure in LIGO-T970168
 - Then, at least 24 hours prior to installation, rinse all fluorel spring seats under running DI water. Direct the water over all surfaces ensuring that they thoroughly wetted for at least 30 seconds. A possible method might be string a number of them like donuts on a rod suspended over a sink so the water can be directed over a number of seats simultaneously.
- If possible, blow them dry using particulate filtered nitrogen, turning as required to reach any trapped surfaces. Then allow to further dry in a clean area overnight.
- Wrap for transport to the installation.

F. Silicone rubber:

small pieces, less than 1.5 cm thick:

- Soak in methylene chloride for 4 days, changing solvent every 24 hours.
- Let air dry at room temperature (under fume hood) for 48 hours.
- Bake in vacuum oven for 10 days at 200 Degrees C.

large pieces: Not allowed.

NOTE: This material is only permitted in 40m and other prototype vacuum envelopes. It may be used in LIGO in isolated evacuated vessels which do not communicate directly with the LIGO vacuum envelope (e.g., low-power reference cavities).

G. Teflon:

parts not requiring high dimensional tolerances:

- ultrasonic clean in acetone for 10 minutes
- ultrasonic clean in methanol for 10 minutes
- bake in vacuum at 120 C for 48 hours

H. Solder:

- same as metals, but flux is to be removed first by spraying Deflux solution.

I. Perkin Elmer Vacseal:

- ultrasonic clean in methanol (see previous footnote) for 10 minutes
- bake in vacuum at 80 C for 48 hrs

J. NEO 35 - permanent magnets:

- ultrasonic clean in methanol (see previous footnote) for 10 minutes
- bake in vacuum at 80 C for 48 hrs

K. PZT piezoelectric ceramics

- ultrasonic clean in methanol (see previous footnote) for 10 minutes
- bake in vacuum at 80 C for 24 hrs

L. Ryton

- ultrasonic clean in methanol (see previous footnote) for 10 minutes

-bake in vacuum at 120 C for 48 hrs

M. Hygroscopic crystalline optics:

- spot clean mounting fixtures with toluene to remove shipping material residue; cleaning shall be under a fume hood.

NOTE: DO NOT BAKE CRYSTAL

NOTE: DO NOT LET SOLVENT CONTACT CRYSTALS; DO NOT EXPOSE CRYSTALS TO SOLVENT FUMES -- KEEP OPEN CONTAINERS OF SOLVENT AT LEAST 1m FROM CRYSTALS. KEEP CONTAINERS CLOSED WHENEVER POSSIBLE.

N. Peekconnectors/Kapton cabling/wire harnesses

- ultrasonic clean in methanol (see previous footnote) for 10 minutes

- bake in vacuum at 200 C for 48 hrs

B Appendix - Forms

Form B1 Parts Cleaning Request

Name _____ Phone _____ Date _____

Parts Description, Dwg # _____ Rev# _____

Used In (next higher assembly) _____

Material:AL SST CST Bronze

 Macor Teflon Viton Glass

Other: _____

Special Handling: _____

Baked In Oven: _____ Load # _____ Temp.: _____ C°

Date In _____ Date out _____

Quantity:

No. of units: _____ and/or (as appropriate) total surface area _____ cm²

Describe total quantity required per LIGO interferometer: _____

Form B1. Parts Cleaning Request

Form B2

LIGO VACUUM BAKE OVEN PROCEDURE AND CHECK LIST

Oven: A B C D VSA Load # _____ Date: ___/___/_____

Load Contents: _____

Cap Torqued: _____ ft/lbs _____ ft/lbs _____ ft/lbs _____ ft/lbs

Metal vlv Open: Y N Vent vlv Closed: Y N TP on ___:___;___/___ TP on ___:___;___/___ TP on ___:___;___/___ TP on ___:___;___/___

Pressure: _____ Torr Date & Time: _____ :_____

Pressure: _____ Torr Date & Time: _____ :_____

NOTE: Do not turn heat on when pressure is above 5E-5 Torr.

AUTO/MANUAL; Heat on: ___:___;___/___

Ramp Time: Oven:___ Hrs, Pumpline:___ Hrs

Soak Time: Oven:___ Hrs, Pumpline:___ Hrs

BAKE TEMPERATURE (C);

Oven: _____ PumpLine: _____ TurboPump Heat On: Y N

TEMPERATURE:(C);

Table with 7 columns: P-Line, End, Body, Cap, Date & Time, P(Torr). Rows 1 and 2 are blank.

TP Heat Off: Y N Temp Cont. sw Off: Y N Reset PROG off: Y N

DEGAS:

Fil On? Y N W/Dycor#___ Date:___/___ Time On:___:___ Time Off:___:___ Date:___/___ Time On:___:___ Time Off:___:___ Date:___/___ Time On:___:___ Time Off:___:___ Date:___/___ Time On:___:___ Time Off:___:___

PURGE: N2 AIR

Comments: _____

Form B2. LIGO Vacuum Bake Oven Procedure and Check List

C Appendix -- Calculation of Vacuum Load

In order to account for the anticipated load on the LIGO vacuum system arising from the introduction of LIGO Detector components into the chambers, it is necessary to develop an accounting system to track the contribution made to the partial pressure gas load by individual detector subsystem components.

C.1. Database

This shall be done by assembling a suitably designed database in which the results of all screenings and high-power exposure tests will be logged. The database shall be searchable/listable according to any of its entries. As a minimum, the database shall contain the following data:

Inventory data:

1. Material, exposed surface area, material volume
2. Subsystem and system comprising material
3. Location, by chamber, of component material

Physical data:

4. Approximate distance to nearest mirror and indication whether there is a direct viewing path
5. Approximate orientation of surface to mirror surface -- needed to estimate viewing factor
6. Pumping speed for HCs in specific location

Measured data:

7. Outgassing rates, by mass number for important complex HC masses
8. Ringdown and frequency shift data: (absorption + loss) and loss rates: ppm/yr.
9. Source of information -- LIGO document number or other traceable reference.

Derived quantities:

10. Partial pressure by mass
11. Predicted accumulation on target mirror, monolayers/yr and estimated (absorption + loss) and loss rates: ppm/yr, where possible or relevant.

C.2. Estimation of material buildup

Optical performance degradation of the LIGO interferometers from material contamination within the vacuum vessels involves three elements: an outgassing source (“culprit”), a target mirror (“victim”), and a path. The outgassing source is most simply characterized by the set of

parameters: $\{A, J_i, m_i, \eta_i, a_i\}$. $A(\text{m}^2)$ is the source surface area exposed to the vacuum, $J_i(\text{W}/\text{m}^2)$ is the outgassing rate for the i^{th} species of contaminant, having mass $m_i(\text{AMU})$, η_i is the affinity for the species to adhere to a (clean) vacuum surface ($0 < \eta_i < 1$), and a_i is the characteristic linear dimension of a molecule of species i (molecular area $\sim a_i^2$). The vessel is maintained at ultrahigh vacuum by a pumping system characterized by a pumping speed for the i^{th} species, $S_i(\text{m}^3/\text{s})$. The target mirror is characterized by the parameters: $\{d_m, \theta_m, A_m\}$. $d_m(\text{m})$ is the distance between mirror surface and outgassing source, θ_m is the orientation of the surface normal to the mirror relative to the line-of-sight to the contamination source and $A_m(\text{m}^2)$ is the mirror surface area. These parameters are summarized in Table 2.

Table 2: Parameters for estimating contaminant buildup on LIGO optics

<i>Parameter</i>	<i>Symbol</i>	<i>Value or Units (SI)</i>	<i>Value or Units (CGS)</i>	<i>Conversion factor, α: $\alpha \text{ CGS} = \text{SI}$</i>
Outgassing rate for species i	J_i	(N-m)/m ² /s or W/m ²	torr-liter/cm ² /s	133.32
Source area	A_i	m ²	cm ²	10 ⁻⁴
Species molecular weight	m_i	AMU		-
Sticking affinity	η_i	$0 < \eta_i < 1$		-
Molecular linear dimension	a_i	m	cm	10 ⁻²
Distance to mirror	d_m			
Mirror area	A_m	m ²	cm ²	10 ⁻⁴
Mirror Orientation	θ_m	-		
Pumping speed for species i	S_i	m ³ /s	liter/s	10 ⁻³
Partial pressure for species i	P_i	N/m ² or Pa	torr	133.32
Rate of increase of optical losses with time	\dot{L}	ppm/yr		

Figure 3 depicts schematically the geometrical arrangement of a source, mirror, and pump system.

Table 3: Physical constants

Physical Constants				
Boltzmann constant	k	$1.38 \cdot 10^{-23}$ J/K	$1.38 \cdot 10^{-16}$ erg/K	10^{-7}
Atomic Mass Unit ¹² C standard; 12 amu = 12 gm / N _A)	amu	$1.66 \cdot 10^{-27}$ kg	$1.66 \cdot 10^{-24}$ gm	10^{-3}
Avogadro's Number	N _A	$6.023 \cdot 10^{23}$		-
Ambient Temperature, 27C	T ₀	300 K		-

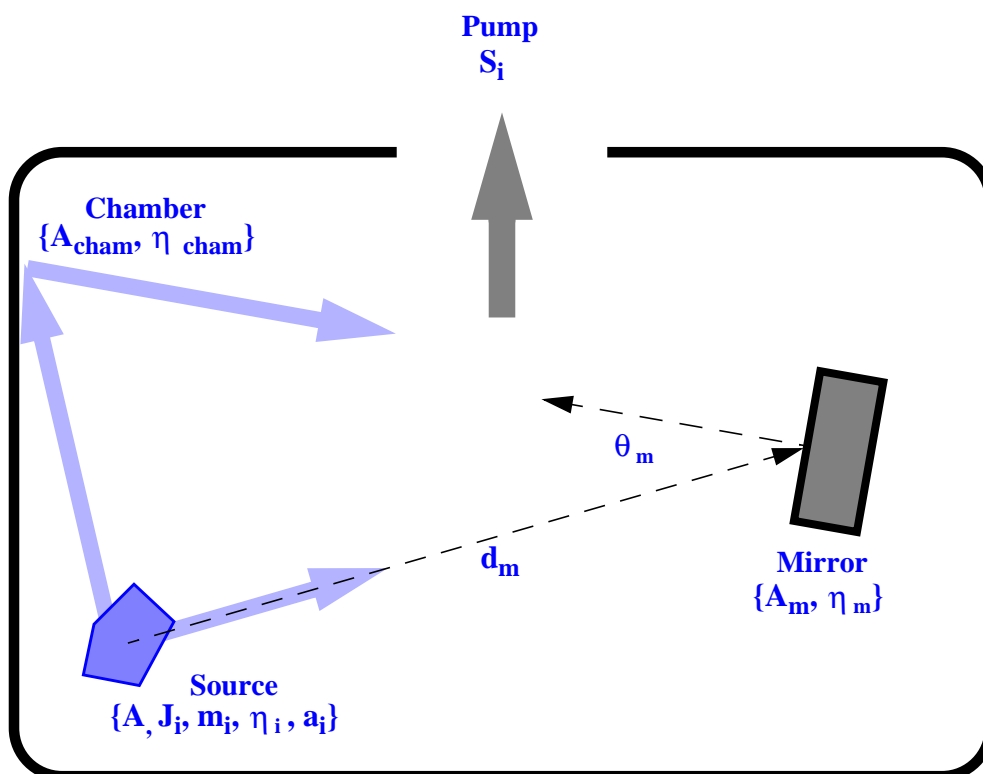
Figure 3: Geometrical arrangement of source, mirror, and pumping system

As shown in the figure, there are (at least) two mechanisms by which contaminants can migrate to a mirror surface: a direct path and an indirect, or diffuse, path involving the equilibrium partial pressure of contaminant species in the vacuum vessel. The following discussion uses statistical mechanical description derives from discussions found in O'Hanlon's *A User's Guide to Vacuum Technology*, 2nd Ed., Wiley Interscience. It may also be reconstructed from material found in Reif's *Statistical and Thermal Physics*, McGraw-Hill. This derivation assumes that

equilibrium has been achieved and does not take into account partial pressure gradients which may be present.

Viewed from the mirror surface, the contaminant flux has a direct component and indirect component determined by the material partial pressure.

$$\Phi_M = \Phi_D + \Phi_p \quad [1]$$

The direct component is given by:

$$\Phi_D = 2.6 \times 10^{18} \frac{J \left(\frac{\text{torr} - \text{liter}}{\text{cm}^2 \text{ s}} \right) A (\text{cm}^2) \cos \theta_m}{d (\text{cm})^2} \quad \# \text{ molecules/cm}^2/\text{s} \quad [2]$$

The indirect component is given by:

$$\Phi_p = 2 \times 10^{21} \frac{P (\text{torr})}{\sqrt{\text{AMU}}} \quad \# \text{ molecules/cm}^2/\text{s} \quad [3]$$

The partial pressure is proportional to the outgassing rate-area product and inversely proportional to the system pumping speed:

$$P = \frac{JA}{S_{\text{tot}}} \quad [4]$$

S_{tot} is the total pumping speed, which may include the pumping provided by the (otherwise clean) vacuum chamber walls:

$$S_{\text{tot}} = S_{\text{pump}} + S_{\text{chamber}} \quad [5]$$

$$S_{\text{chamber}} = \eta_{\text{Chamber}} A_{\text{chamber}} \left[\frac{kT}{2\pi m} \right]^{\frac{1}{2}} \quad \text{liter/s} \quad [6]$$

Φ_D is given in eq. [2] above. The worst case is given by $\eta_{\text{Chamber}} \approx 0$, in which case the contaminants do not adhere to the chamber walls and the only pumping action is provided by the pumping system itself. In this limit, the molecular flux incident on the mirror surface at room temperature is given by:

$$\Phi_M = J \left(\frac{\text{torr} - \text{liter}}{\text{cm}^2 \text{ s}} \right) \cdot A (\text{cm}^2) \left(2.6 \times 10^{18} \frac{\cos \theta_m}{d (\text{cm})^2} + 2 \times 10^{21} \frac{1}{S (\text{liter/s}) \sqrt{\text{AMU}}} \right) \quad [7]$$

Note that d scales weakly as $\text{AMU}^{1/4}$: using $S \approx 1000$ liter/s, the distance scale where the two contributions become comparable for $\text{AMU}=36$ is $d \approx 3$ cm, and for $\text{AMU} = 500$ $d \approx 5$ cm.

The rate accumulation of material on a surface depends on the physical dimensions of a molecule, a_i . A simple model-independent estimate of this dimension may be obtained by considering a substance's molecular weight and density. Many hydrocarbon have densities which are comparable to that of H_2O , $\rho \approx 1 \text{ gm/cm}^3$ (at least they will not differ from this value too greatly). The molecular volume is estimated by:

$$V_{\text{mol}}(\text{cm}^3) = \frac{\text{AMU}(\text{gm})}{N_A \cdot \rho(\text{gm/cm}^3)} \sim [a_i]^3 \quad [8]$$

This yields $a_i = 0.12 \cdot \left[\frac{\text{AMU}}{\rho(\text{gm/cm}^3)} \right]^{\frac{1}{3}} \text{ nm}$. For $\text{AMU} = 36$, this yields $a_i = 3.9 \text{ \AA}$ and $a_i^2 =$

15.3 \AA^2 or $1.5 \cdot 10^{-15} \text{ cm}^2$. Using this dependence of molecular size on molecular weight

(assuming a constant density of $\sim 1 \text{ gm/cm}^3$), the following expression obtains for the rate of monolayer buildup:

$$\frac{\# \text{ layers}}{\text{yr}} \approx 3 \times 10^7 \eta_M \Phi_M a_i^2 \quad [9]$$

For $\eta_M \approx 1$ and $S_0 = 1000 \text{ liter/s}$, this yields:

$$\frac{\# \text{ layers}}{\text{yr}} = J \left(\frac{\text{torr} \cdot \text{liter}}{\text{cm}^2 \cdot \text{s}} \right) \cdot A(\text{cm}^2) (\text{AMU})^{\frac{2}{3}} \left(1.1 \times 10^{10} \frac{\cos \theta_m}{d(\text{cm})^2} + 8.9 \times 10^9 \frac{1}{\sqrt{\text{AMU}}} \right) \quad [10]$$

This represents a worst-case estimate because it assumes that all molecules adhere to the mirror surface and remain there indefinitely. T980008, "Bake Oven Requirements and Conceptual Design," Appendix 1, discusses the effect of considering surface dwell time for contaminating molecules.

Eq. 10 will be implemented in the database which predicts the build up of material on mirrors from outgassing products.

C.3. Extrapolation of optical losses in LIGO from high-power cavity tests

The least model-dependent estimate of the potential for mirror contamination in LIGO comes from in-situ exposure of resonant cavities to samples of materials. Extrapolation of laboratory test results to LIGO will be performed as follows.

Assume that the ratio of loss buildup to material buildup, $\kappa \equiv \left[\frac{\delta \dot{L}}{\delta \dot{x}} \right]$, is an intrinsic property of the material under evaluation. Here \dot{L} is the rate of increase of optical loss (absorption or absorption-plus-scatter) in ppm/yr *per optical surface* and \dot{x} is the material buildup rate in monolayer/yr. Then, using equation 10 (and reintroducing the pumping speed dependence into numerator and denominator), the extrapolation from a laboratory-scale measurement to LIGO follows:

$$[\dot{L}]_{\text{LIGO}} = [\dot{L}]_{\text{Test}} \frac{A_{\text{LIGO}}(\text{cm}^2) \left(1.1 \times 10^{10} \frac{\cos \theta_{m, \text{LIGO}}}{d_{\text{LIGO}}(\text{cm})^2} + 8.9 \times 10^{12} \frac{1}{S_{\text{LIGO}} \sqrt{\text{AMU}}} \right)}{A_{\text{Test}}(\text{cm}^2) \left(1.1 \times 10^{10} \frac{\cos \theta_{m, \text{Test}}}{d_{\text{Test}}(\text{cm})^2} + 8.9 \times 10^{12} \frac{1}{S_{\text{test}} \sqrt{\text{AMU}}} \right)} \quad [11]$$

Note that if either the setup or the LIGO installation for the material does not have a direct view of the mirror, then the corresponding term in Eq. 11 will be equal to zero.

C.4. Determination of outgassing for highly condensible organic molecules

The calculations required to determine the surface coverage of a condensible gas are not as straightforward as estimating the surface coverage for an almost noncondensable gas. The surface coverage is not determined by merely calculating the flux onto the surface and multiplying by the product of the accommodation coefficient times the exposure time. The surface adsorbs and re-emits molecules and when out of equilibrium has an enormous pumping or emission capacity that dwarfs the pumping speed of the system. Hence, the simple technique of estimating the outgassing rate of a substance by measuring the partial pressure of the gas, multiplying by the pumping speed of the system and dividing by the exposed area of the substance can result in substantial errors if the system is out of equilibrium. The estimated outgassing rate is smaller than the actual rate.

A better approach is to use the Dubinin-Radushkevich adsorption theory (Refer to LIGO T920009-00-R). In this theory at equilibrium, the surface coverage is given by

$$\frac{\sigma}{\sigma_m} = e^{-\left(\frac{T}{T_0} \ln \left(\frac{P}{P_0} \right) \right)^2}$$

σ is the surface coverage in monolayers or torr liters/cm² while σ_m is the maximum surface coverage. At this coverage the equilibrium vapor pressure is P_0 . T_0 is the average molecular binding energy to the surface expressed as a temperature and T is the temperature, both in K. The figure

indicates the parameters used to apply the theory to our measurements. A substance with outgassing rate J (torr liters/sec cm^2) is placed in the vacuum system. The emitting area of the substance is A_s . The surface area of the vacuum system (including the stuff placed inside of it) is A_{sys} . The pumping speed out of the vacuum system is F (liters/sec) and the pressure throughout the volume of the system, V (liters), is P (torr).

Figure 4: Schematic for the calculation. A substance that outgasses a condensible material has a surface area A_s , in the figure located in a sidearm of the system, though this is not essential to the model. The surface of the system initially has no surface loading of this material. The question is how to estimate the surface loading of the system as a function of time.

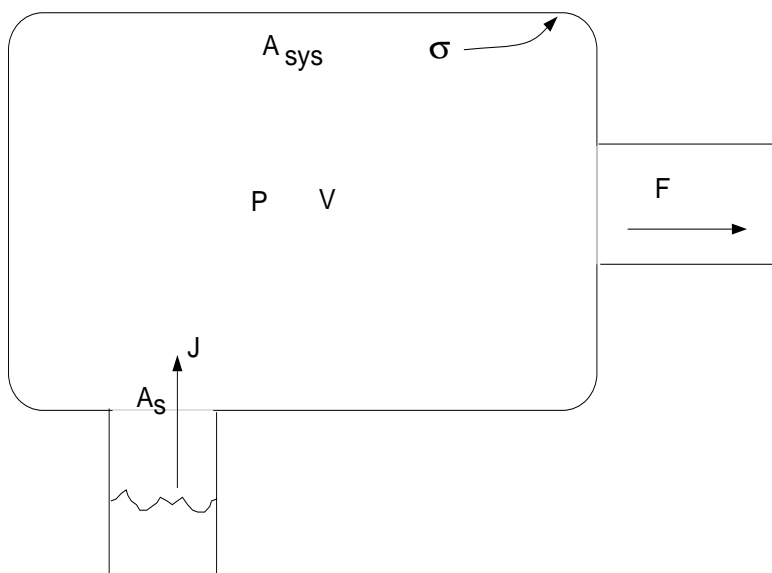

If one can assume that the pressure in the system is appropriate to the surface coverage given by the Dubinin-Radushkevich adsorption theory, the system is in a “dynamic” equilibrium on the collecting surface. There is still a net flow from the sample to the surface so there is no global equilibrium. Under these assumptions, the particle conservation equation is

$$\frac{dN}{dt} \text{ emitter} = \frac{dN}{dt} \text{ wall} + \frac{dN}{dt} \text{ pump out} + \frac{dN}{dt} \text{ volume}$$

which can be rewritten in terms of the system parameters as

$$A_s J(T) = \frac{d\sigma}{dt} A_{\text{sys}} + PF + \frac{dP}{dt} V$$

The first order differential equation for the evolution of the pressure in the system becomes

$$\frac{dP}{dt} = \frac{A_s J(T) - PF}{V + 2(z/P) A_{\text{sys}} \sigma_m}$$

where

$$z = \left| \ln \frac{P}{P_0} \right| \left(\frac{T}{T_0} \right)^2 e^{-\left(\frac{T}{T_0} \ln \left(\frac{P}{P_0} \right) \right)^2}$$

When the system is initially exposed to the source, the surface coverage is small and the dynamical equilibrium pressure is small. The denominator of the pressure derivative equation is dominated by the surface term and the numerator by its surface term. The time it takes for the system to come to pumping speed equilibrium where $\frac{dP}{dt} = 0$ and $P = \frac{A_s J(T)}{F}$ is approximately given by

$$\tau \sim 3 \frac{\left(2A_{\text{sys}} \sigma_m \left| \ln \left(\frac{JA_s}{FP_0} \right) \right| \left(\frac{T}{T_0} \right)^2 \right)}{JA_s}$$

In order to determine the surface adsorption parameters, σ_m , P_0 and T_0 it is useful to measure the pressure changes vs. time by accumulation methods and to determine the equilibrium pressure under different pumping speeds and temperature. Typical values for water determined from the beam tube project are given in Table 4.

Table 4: Typical values for water on hot rolled 304L stainless steel

T_0	1.0×10^4 K
σ_m	100 monolayers = 2.8×10^{-3} torr liters/cm ²
P_0	1.0×10^{-3} torr
$J(300\text{K})$	1.0×10^{-8} /t (hours) torr liters/sec cm ²

An example calculation for a source in one of the LIGO instrumentation tanks might give an equilibration time of 200 days using typical parameters given in Table 5.

Table 5: Sample parameters leading to 200 day equilibration time

T_0	10^4 K
T	300 K
J	10^{-9} torr liters/sec cm^2
P_0	10^{-3} torr
σ_m	100 monolayers = 2.8×10^{-3} torr liters/ cm^2
F	10^3 liters/sec
A_{sys}	10^6 cm^2
A_s	10^4 cm^2

Figure 5 shows the relation between the surface coverage and the equilibrium pressure for the Dubinin - Radushkevich theory. The enormous range in pressure for a small change in surface coverage is the fundamental reason for the vacuum “stiffness” of the process.

Figure 5: Relation between the surface coverage and the equilibrium pressure for the Dubinin - Radushkevich theory

