

# CRYOGENIC PAYLOADS FOR 3<sup>RD</sup> GENERATION GW INTERFEROMETERS

Paola Puppo

*INFN – Rome*

*Ft Lauderdale GWADW – May 14<sup>th</sup> 2009*

# WHY TO COOL THE MIRRORS?

- ✗ Test masses and suspensions thermal noise reduces at low temperature:

$$\langle x^2 \rangle \propto T$$

- ✗ Thermoelastic noise both of the mirror substrates and coatings decrease:

$$\langle x^2 \rangle \propto \alpha T^2$$

- ✗ Thermal expansion rate  $\alpha$  decreases at low temperature;

- ✗ Thermorefractive noise

$$\langle x^2 \rangle \propto T^2$$

- ✗ Losses of some materials decrease at low temperature

$$\langle x^2 \rangle \propto T \Phi$$

# CRYOGENIC 3° GENERATION GW DETECTOR

ET dummy curve, file=ET\_sthild\_12.m

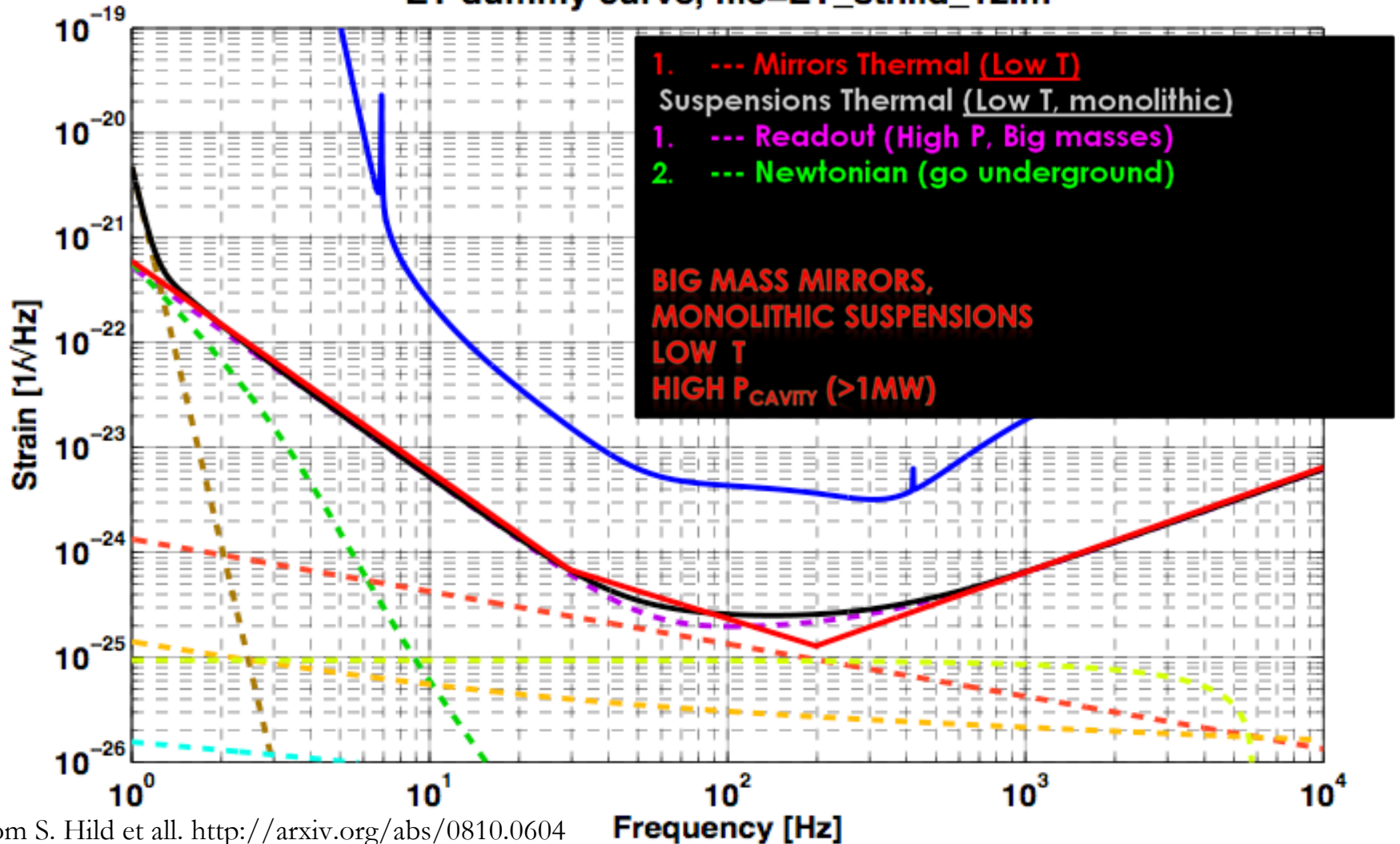

From S. Hild et al. <http://arxiv.org/abs/0810.0604>

G0900642-v1

# Mirror laser heating at cryogenic temperatures

thermal gradient on a Virgo mirror

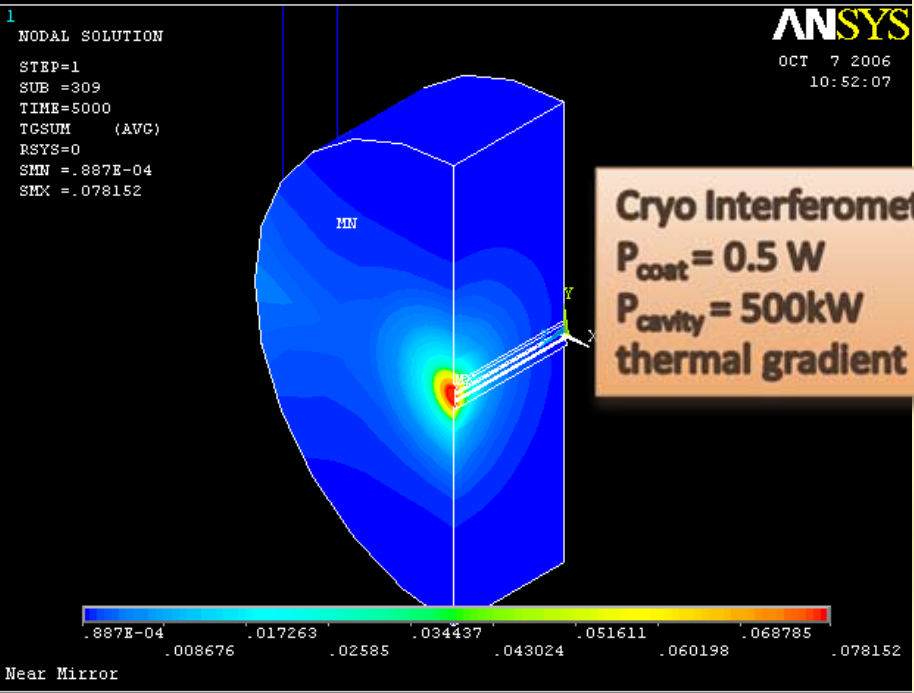

Cryo Interferometer  
 $P_{coat} = 0.5 \text{ W}$   
 $P_{cavity} = 500 \text{ kW}$   
 thermal gradient

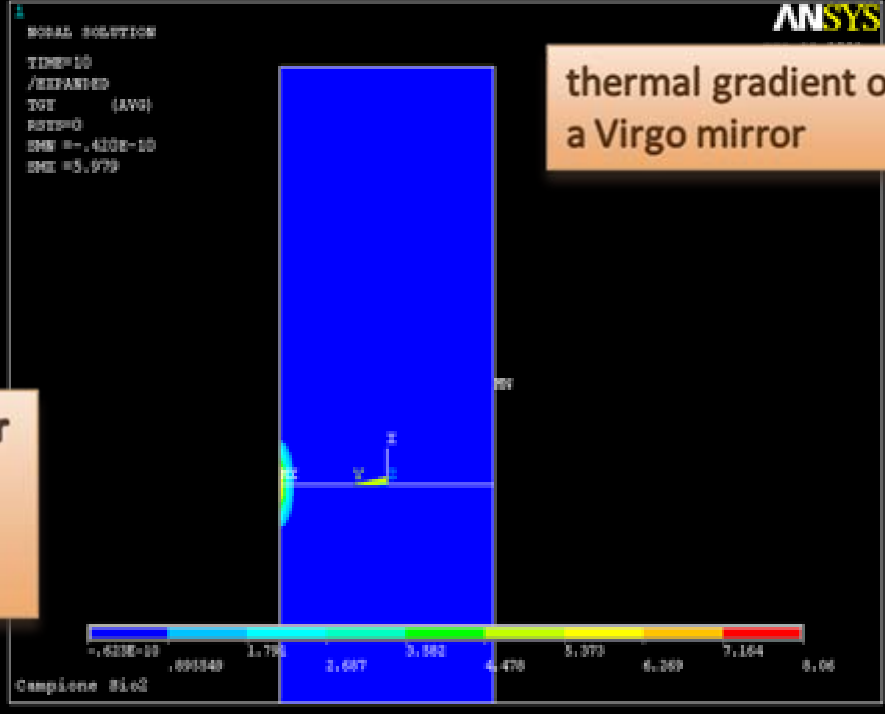

## Cryogenic Silicon Payload

$$\left| \vec{\nabla} T_{cryo} \right| \approx 10^{-2} \left| \vec{\nabla} T_{virgo} \right|$$

$$P_{coat}^{cryo} \approx 20 P_{coat}^{virgo}$$

- At cryogenic temperatures, the thermal conductivity increases and consequently reduces thermal gradients on the coating;
- Refraction index variation with temperature is very small at low temperature;

~ The thermal lensing is likely to be zero because the thermal expansion coefficients tend to zero at cryogenic temperatures;

# HOW CAN WE COOL THE MIRRORS?

## ↗ Mirror and its suspension wires:

- wires and mirror materials compatible with good mechanical and thermal properties;
  - High thermal conductivities materials;
  - Low mechanical and optical losses;

a promising material both as mirror substrate and wire is silicon having

- high thermal conductivity
- very low thermal expansion (zero below 17K)



# Pulse Tube Cryocoolers

The modern Pulse Tube cryocooler traces its history back to **Alexander Mikulin (1895-1985)**, Academician of the Academy of Sciences (Soviet Union), who in 1984 modified a device known as the "basic pulse tube" and reached a temperature of 105 K.

Mikulin's modification created a new class of cryocooler, the "**Orifice Pulse Tube**" cryocooler.

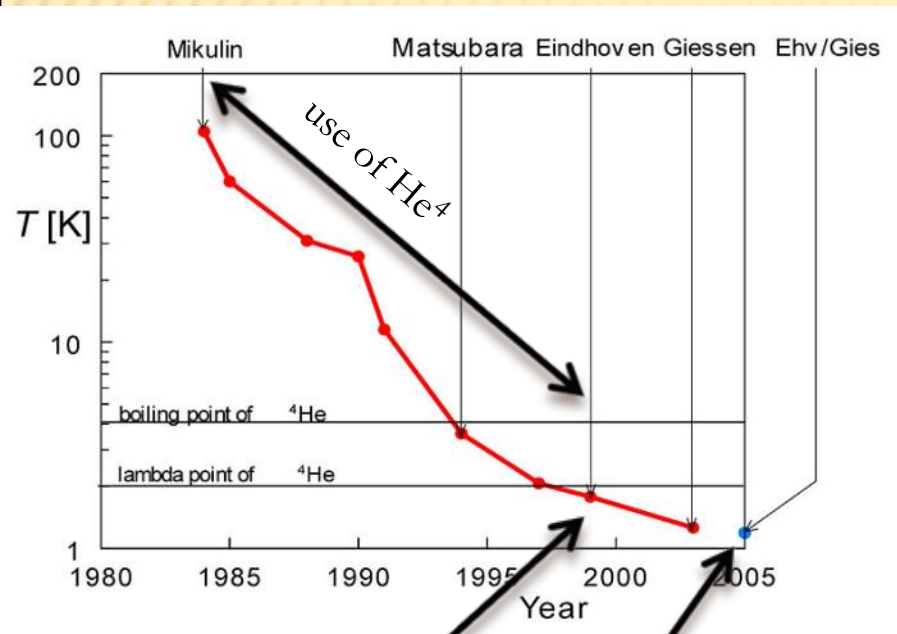

Subsequent research in the US and abroad led to rapid development of this technology, and by the **mid 1990's**, temperatures below 4 K had been reached by several groups.

Compared to the Stirling Cycle, Gifford-McMahon (G-M), and Joule-Thomson (J-T) cryocoolers most often used today, **development of Pulse Tube cryocoolers is still at an early stage.**

below  $\lambda$  point (down to 1.3 K): use of  $\text{He}^3$  (Xu et al, Cryogenics, 34 (1999))

1.2 K: Supervortex cooler (Adv.Cryo.Tech 49B,2006)

# The new generation of Cryogenerators

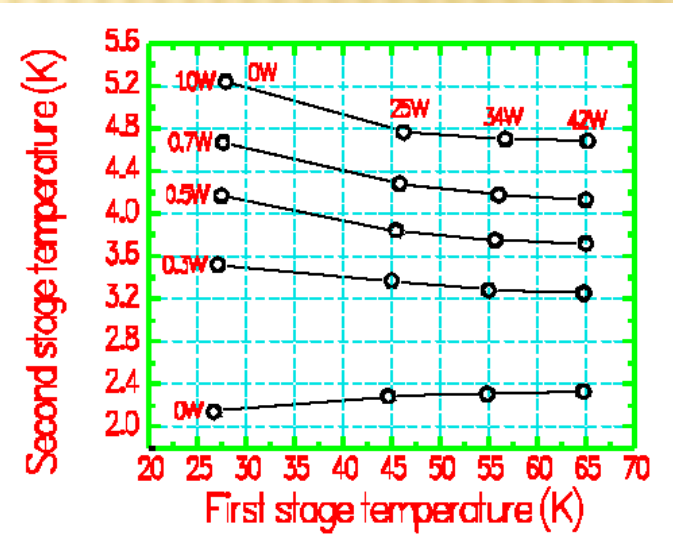
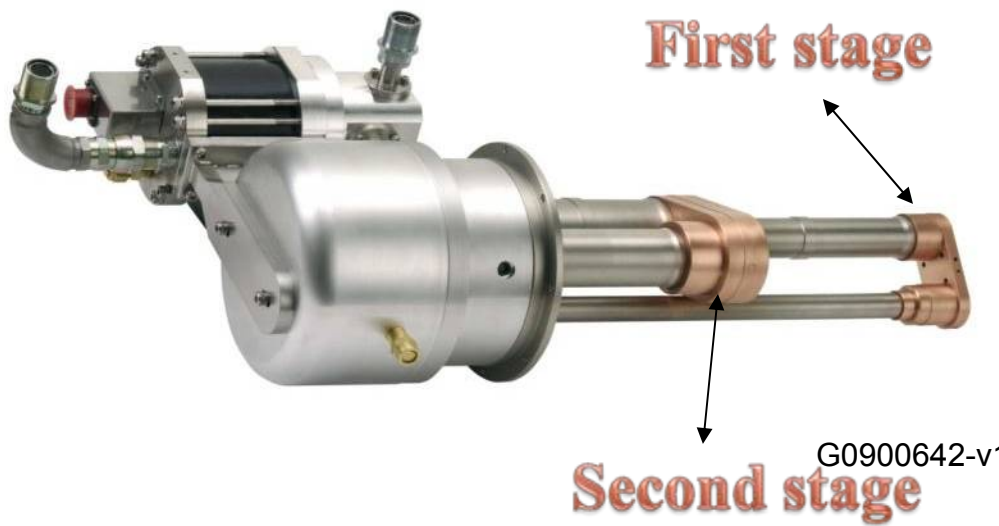
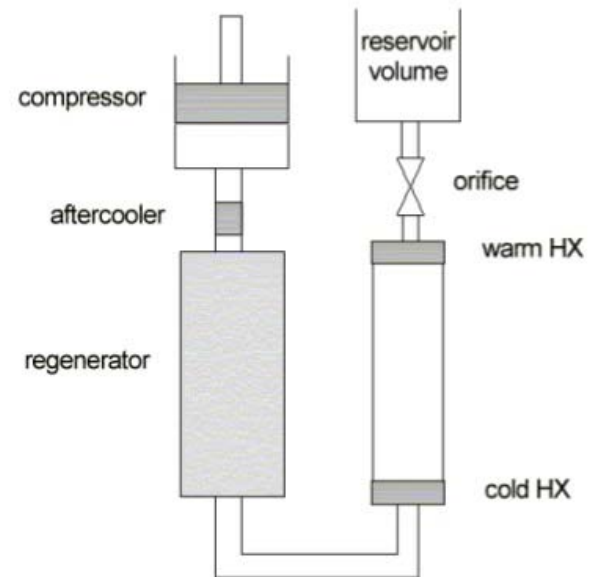
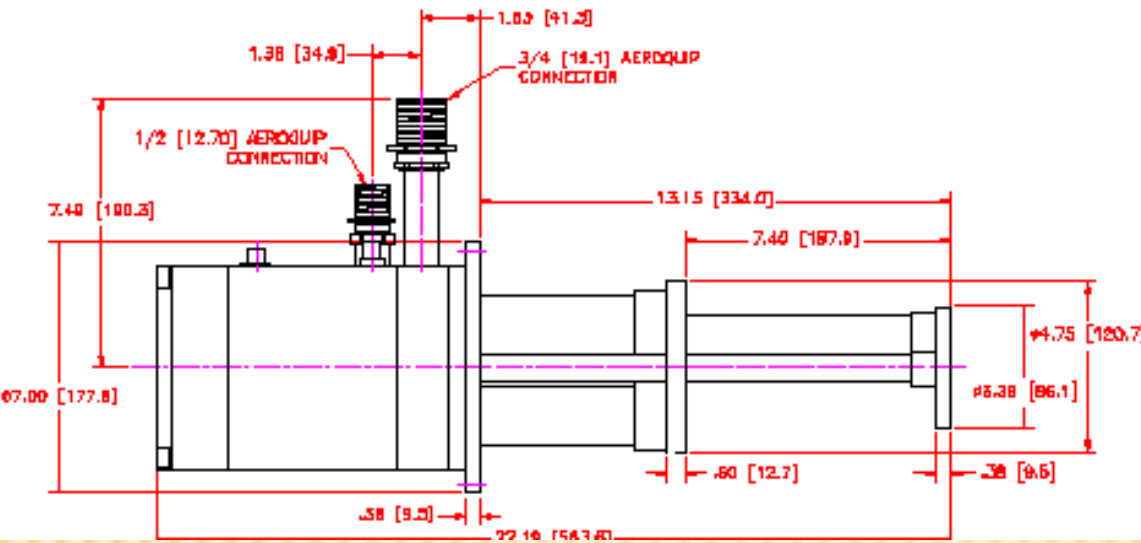



ILIAS: STREGA project *JRA3 / S.T.R.E.G.A.*  
(closed in April 2009)

- **Advanced Materials**
- **Thermal noise studies**
- **Cryogenics**

ET: WG2 (Thermal Noise, Suspension, Cryogenics)



Image © 2006 EarthSat

ET

EINSTEIN  
TELESCOPE



# The Free Vibration Cryostat and its control chain

S. Caparrelli, et al. Rev. of Sci. Inst. 77, 095102 (2006).

T. Tomaru et al. Cryogenics, 44 (2004). (*Passive vibration insulation system for the cryocooler*)

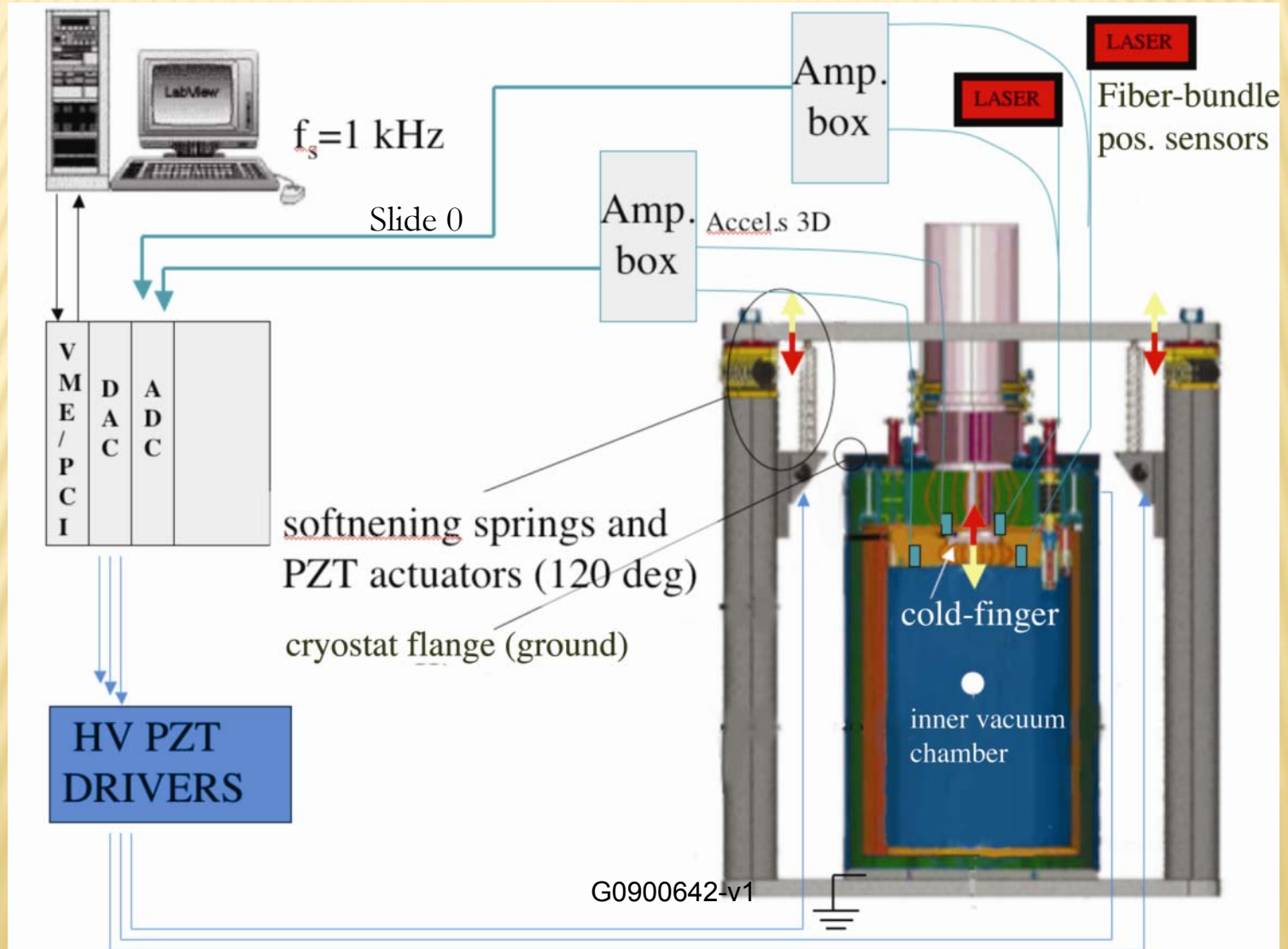

# Vibration of the cold head reduced (@T=4K)

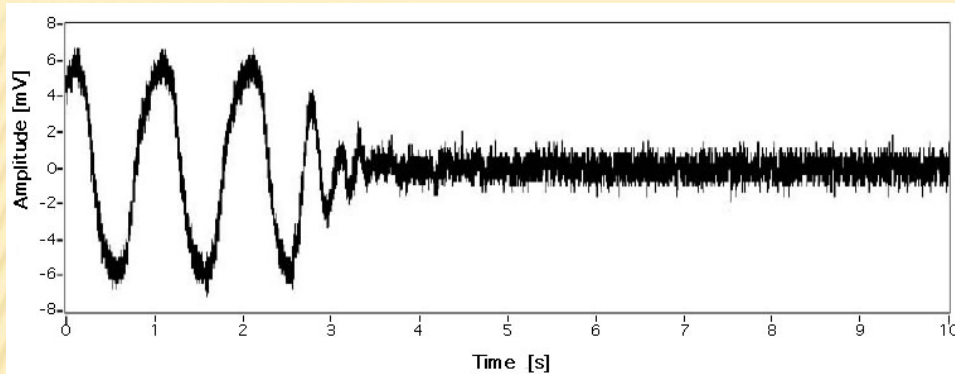

displacement noise density

$$\Delta x = 29 \left[ \mu\text{m} / \sqrt{\text{Hz}} \right] \quad @ 1 \text{ Hz}$$

$$\frac{\Delta x_{OL}}{\Delta x_{CL}} = 117 \quad @ 1 \text{ Hz}$$

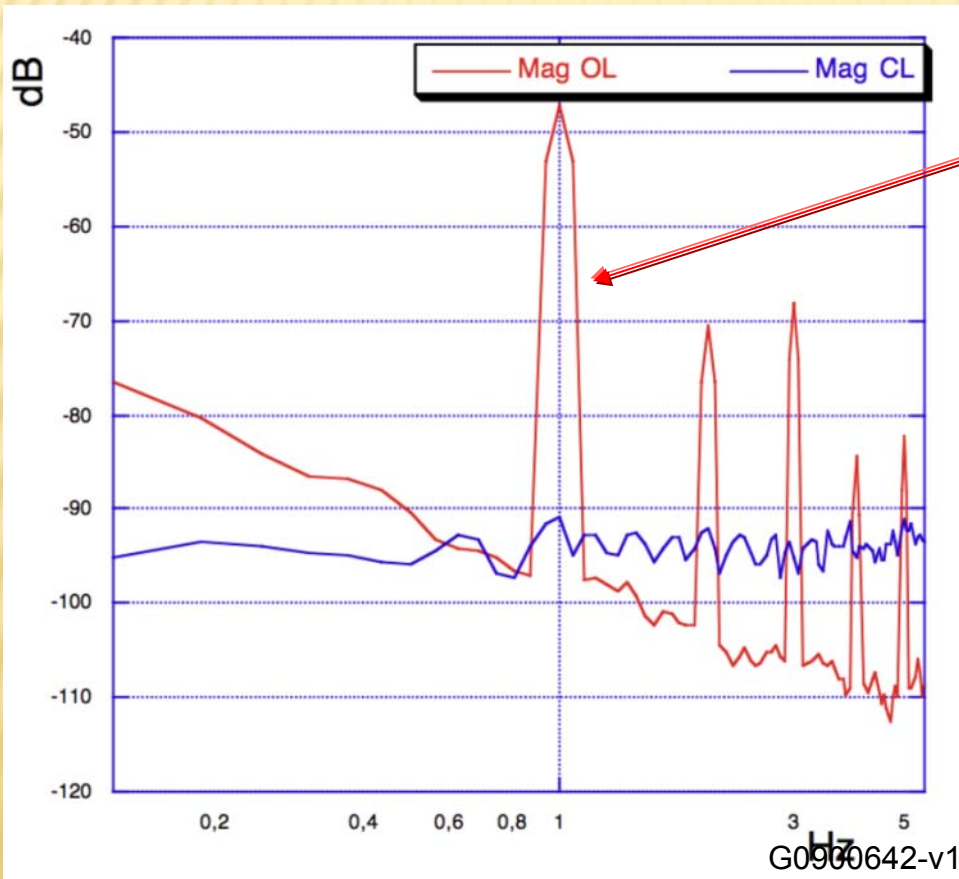

The vibration reduction scheme works

The sensing will be modify to reduce the noise floor at closed loop.

**Last result:**

$$\frac{\Delta x_{OL}}{\Delta x_{CL}} = 220 \quad @ 1 \text{ Hz}$$

# SILICON FOR SUBSTRATES AND SUSPENSIONS: SI THERMAL PROPERTIES

- ✘ high thermal conductivity
- ✘ very low thermal expansion (zero below 17K)



Thermal Conductivity (W/m/K)

Thermal expansion (1/K)

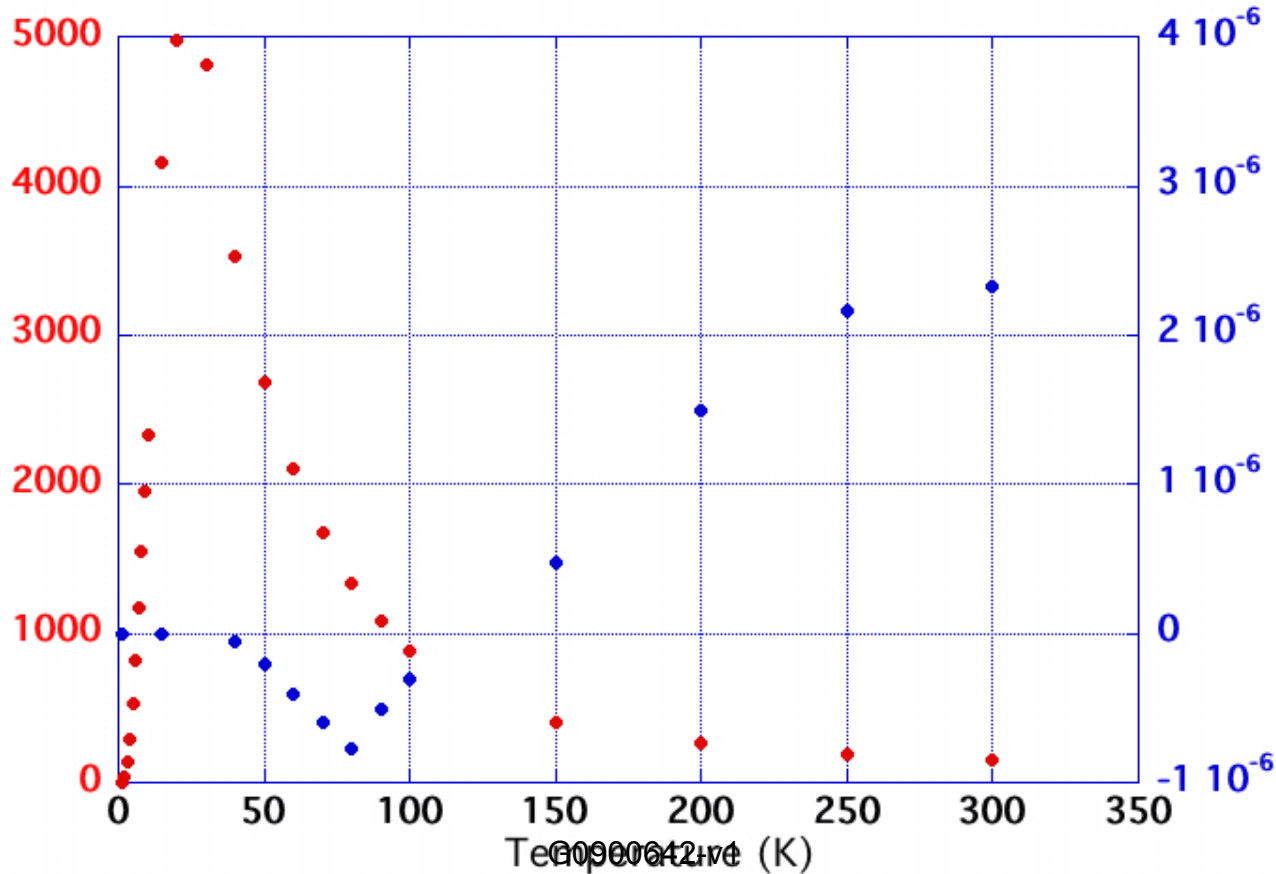

# OTHER PROMISING MATERIALS FOR THE MIRROR SUSPENSION WIRES: HIGHER THERMAL CONDUCTIVITY AND GOOD MECHANICAL PROPERTIES

## Doped Silicon

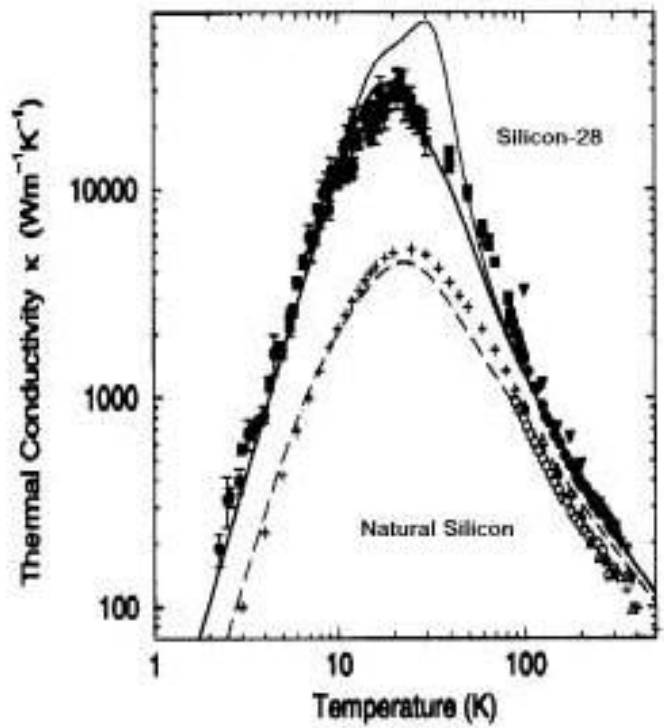

## Pure Aluminum

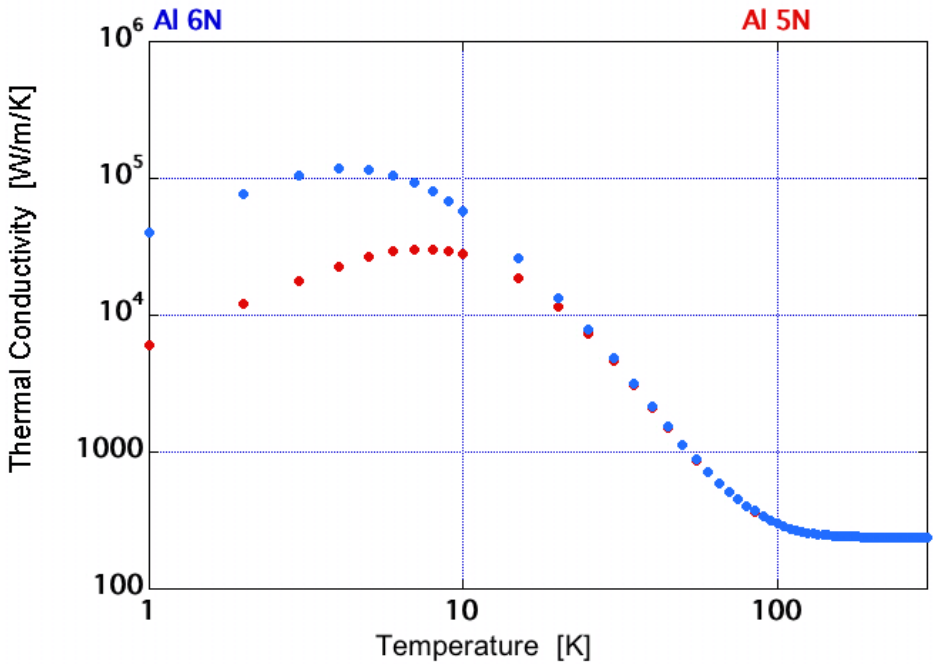

"Thermal Conductivity of Isotopically Enriched Silicon," T. Ruf, et al, **Solid State Communications**, Vol 115, No. 5, p.243 (2000).

A. Woodcraft, "Recommended values for the thermal conductivity of aluminium of different purities in the cryogenic to room temperature range, and a comparison with copper" **Cryogenics** 45(9):626-636, 2005.

# THE SILICATE BONDING TECHNIQUE

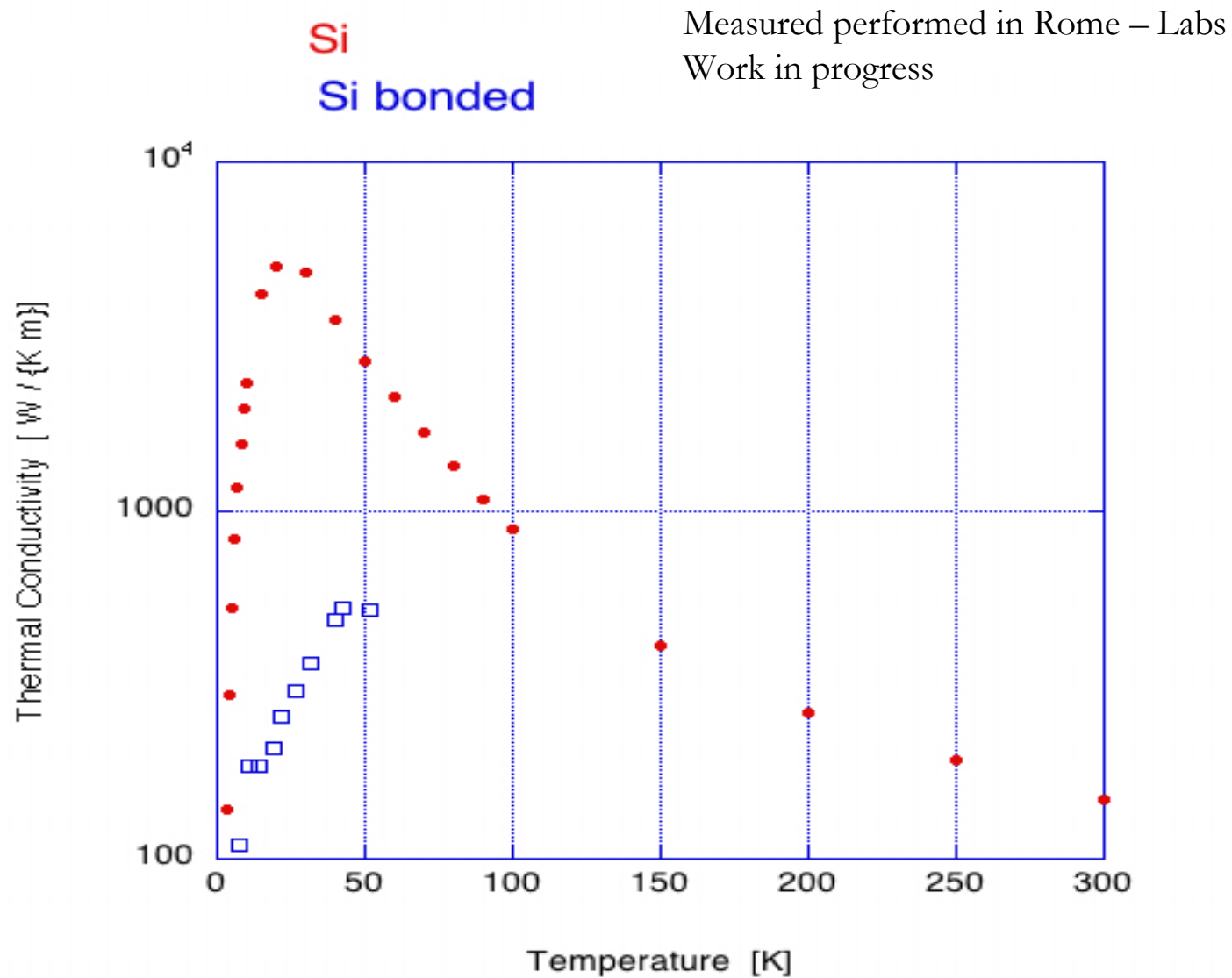

G0900642-v1

# Principle scheme

•  
 $\dot{Q}$  from refrigerator

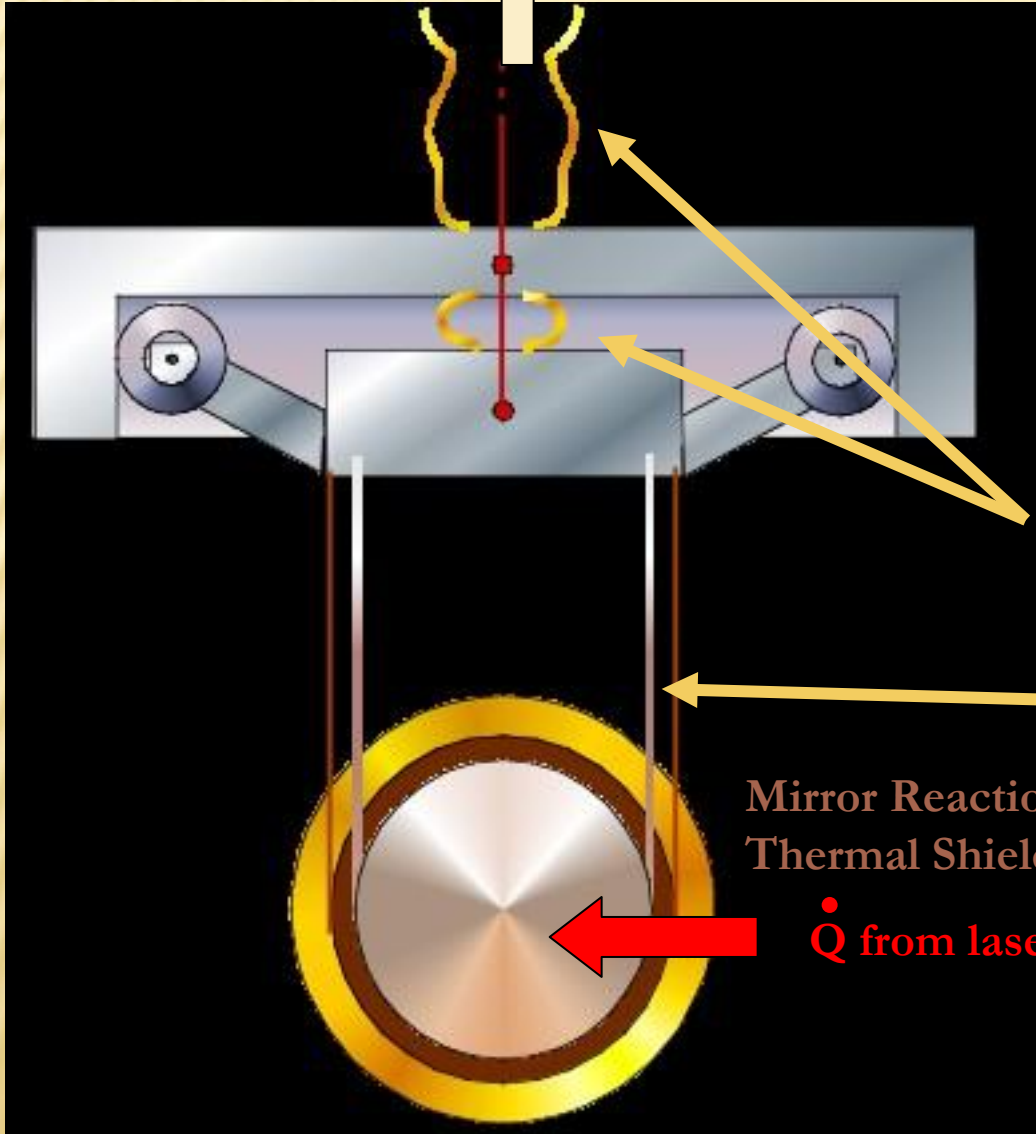

Marionetta Reaction Mass:  
Thermal Shield

High Efficiency Soft Thermal Links  
(e.g. pure Al, copper)

Silicon Monolithic Suspension

Mirror Reaction Mass:  
Thermal Shield

•  
 $\dot{Q}$  from laser beam

# Cryo-Compatible Superattenuator design

- High Thermal impedance MRM wire
- The upper part is thermally insulated by thermal screens

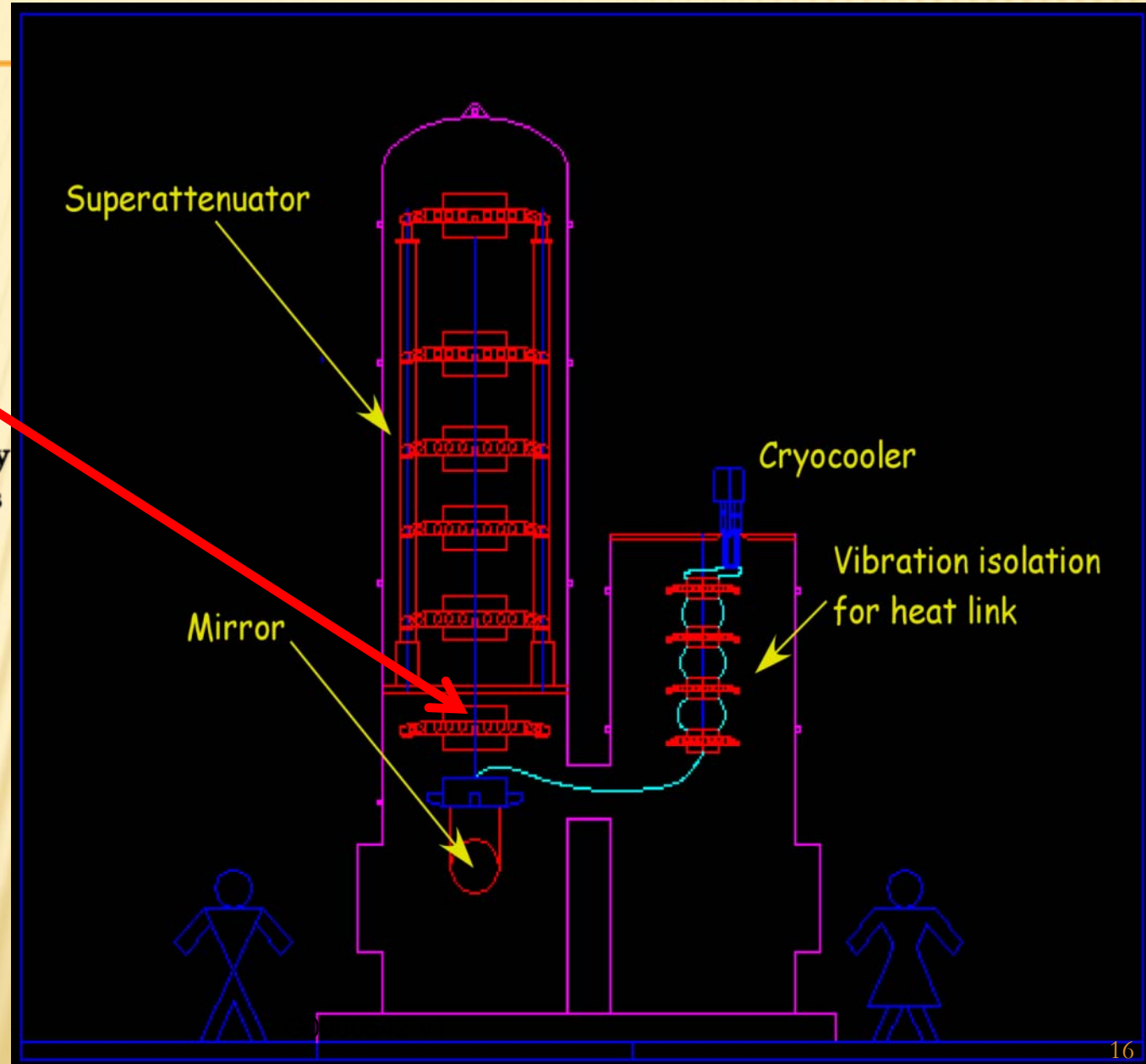

# 2008: Full Scale Cryogenic Payload

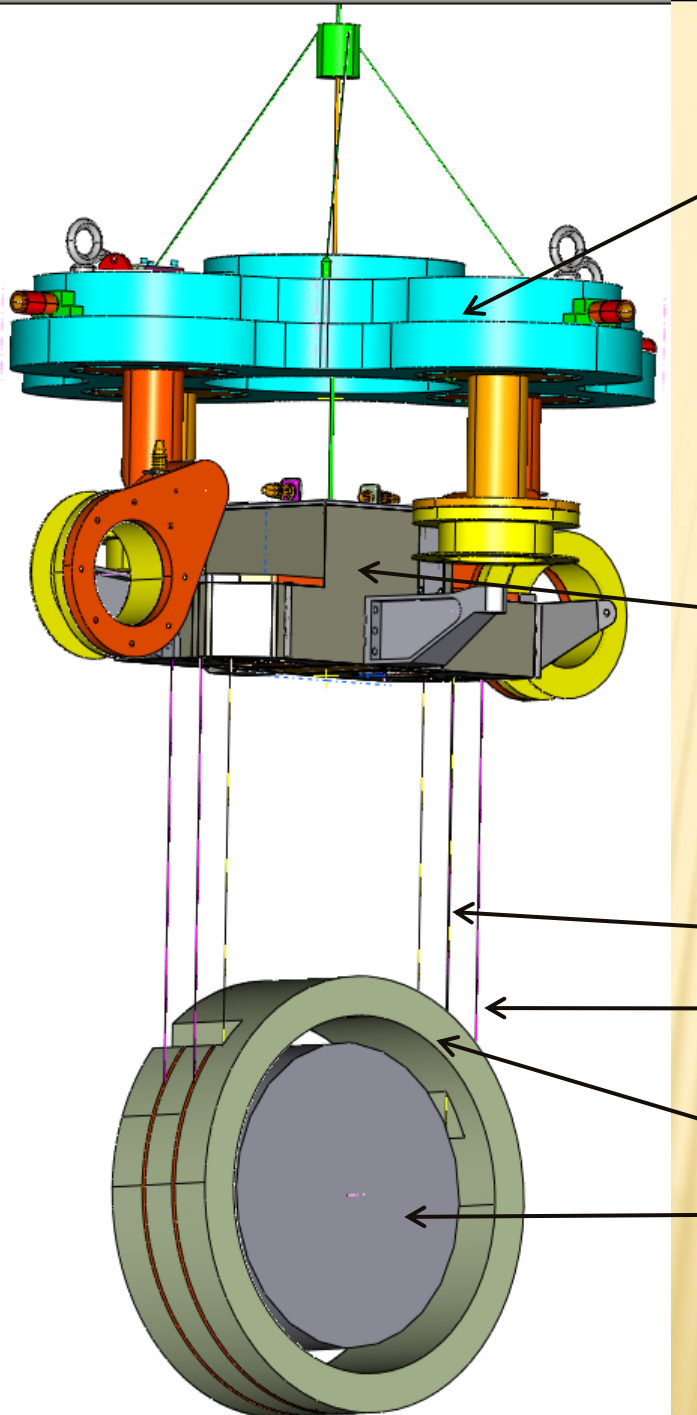

- Marionetta Reaction Mass (MRM)
- Ti alloy cable (low thermal conductivity) Ti-6Al-4V

• Marionetta

• Mirror silicon Wires

• Reaction Mass high conductive wires

• Reaction Mass  
• (Al Alloy)

• Silicon mirror

- Main Requirements**
1. Internal frequencies as high as possible
  2. Low pendulum and torsional frequencies (mirror control).
  3. Good thermal properties for cryogenic operation





# Reaction Masses

## Mirror's

### Marionetta's

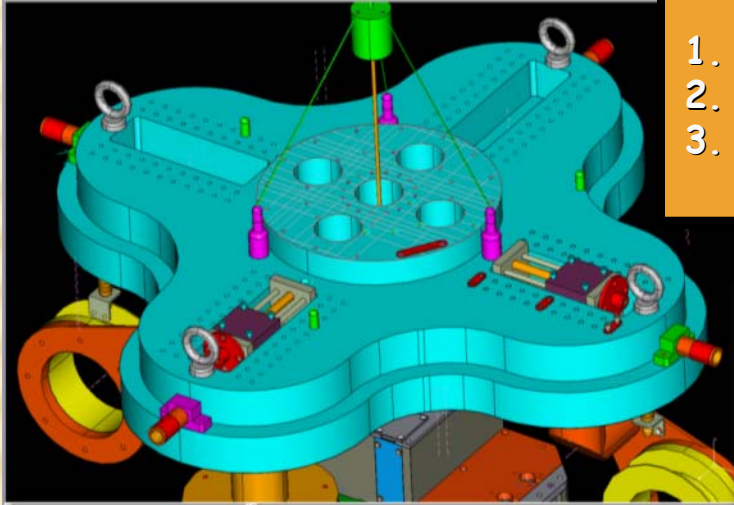

- Main Properties**
1. Supports the e.m. actuators
  2. Act as thermal screen
  3. Protect the mirror
- Made of Al alloy

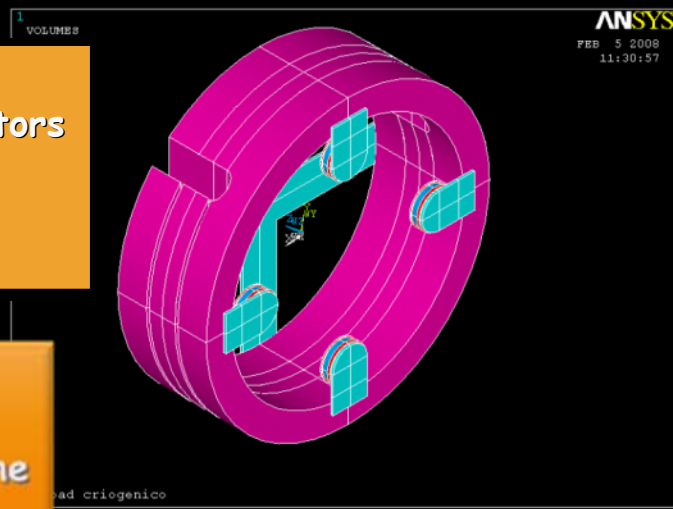

- FEM mechanical**
- Lowest frequency for the Mirror RM: 600 Hz
- Lowest frequency for the MRM: 400 Hz

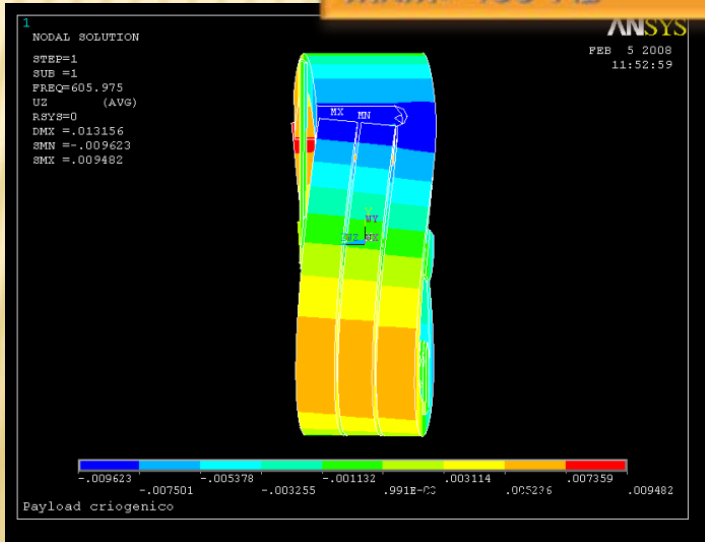

# FEM study of the MRM

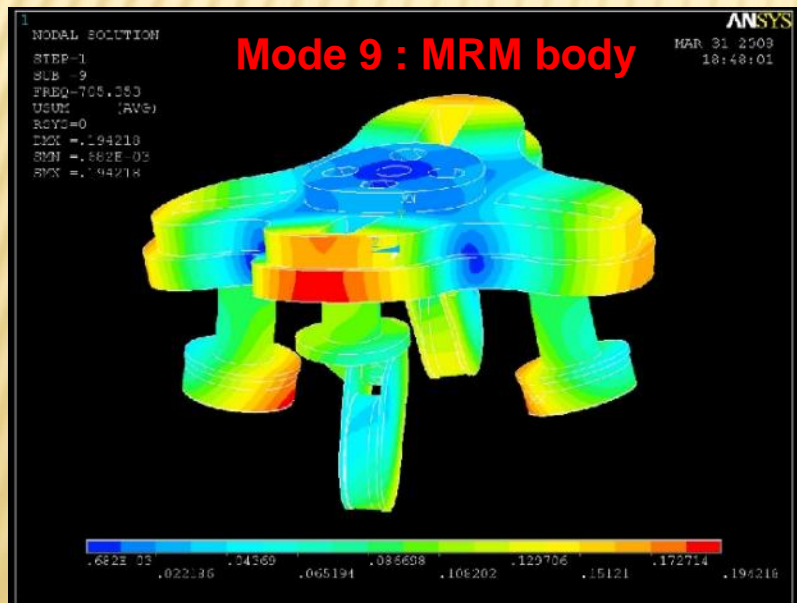
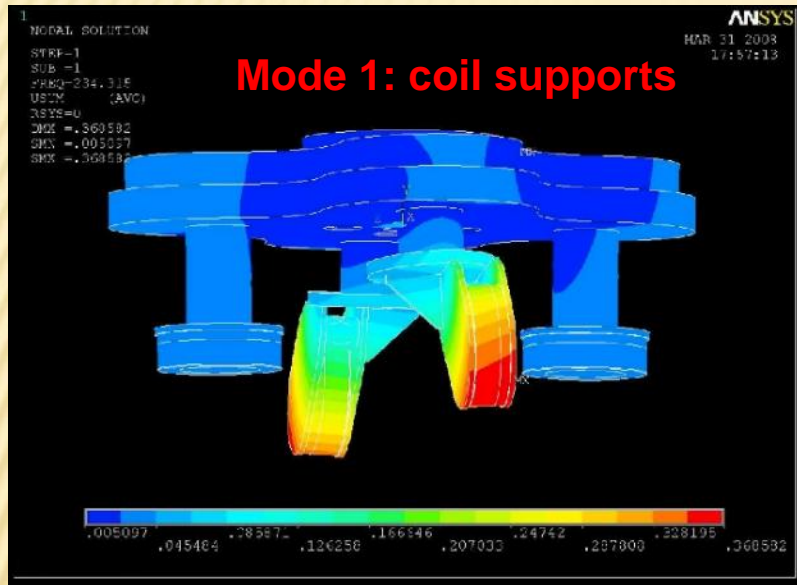

Mode number	Frequency (Hz)	Mode identification
1	234	Bending of the horizontal coil support
2	262	Bending of the horizontal coil support
3	270	Bending of the horizontal coil support
4	300	Bending of the horizontal coil support
5	377	Bending of the vertical coil support
6	419	Bending of the vertical coil support
7	472	Bending of the vertical coil support
8	476	Bending of the vertical coil support
9	705	Anti symmetric butterfly mode of the plate
10	755	2° harm. of the Bending of the horiz. coil support
11	763	2° harm. of the Bending of the horiz. coil support
12	789	Longitudinal vibration of the vertical coil support
13	794	Longitudinal vibration of the vertical coil support
14	1106	Longitudinal vibration of the horizontal coil support
15	1164	Torsion mode of the plate
16	1171	Torsion mode of the plate
17	1316	Radial mode of the plate
18	1382	Symmetric butterfly mode of the plate
19	1544	Radial mode of the plate
20	1621	Torsion mode of the plate

# Marionetta

## Main Characteristics

1. Lateral cuts for the insertion of the silicon wires
2. Copper clamps
3. Copper links with the cooler
4. Dielectric arms epoglass FR4 (no eddy currents)
5. No magnetic steel body

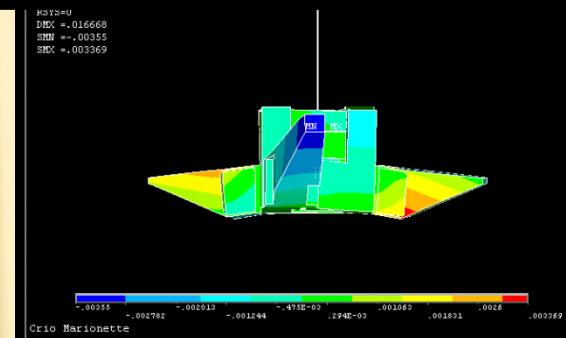
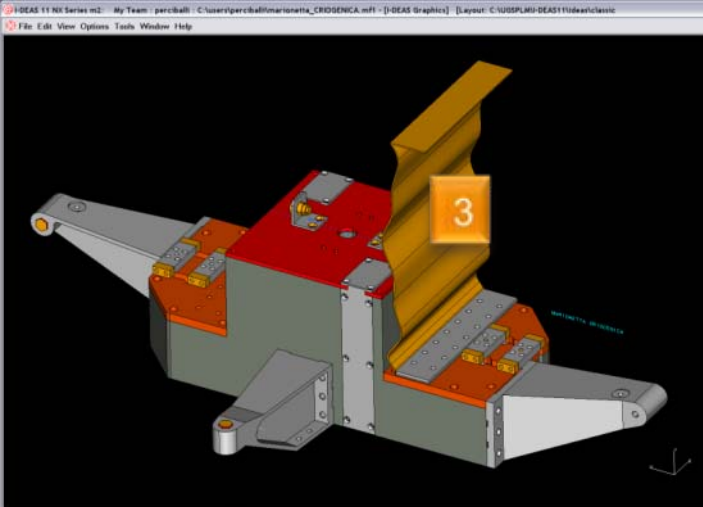

ANSYS  
MAY 13 2008  
15:35:33

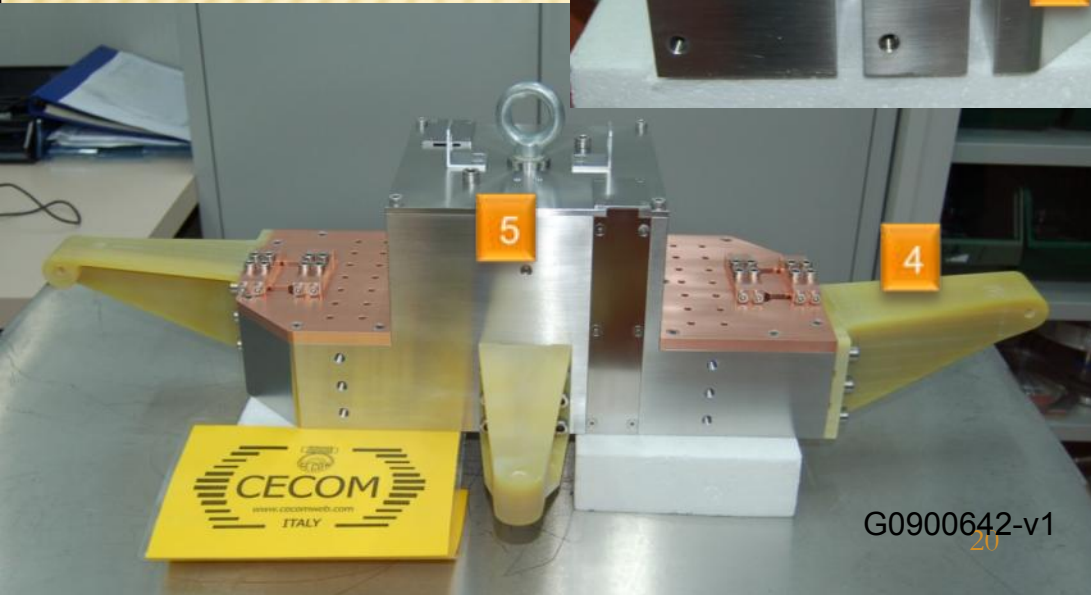

## Marionetta internal modes

Body: lowest 2300 kHz  
Arms: lowest 1100 Hz

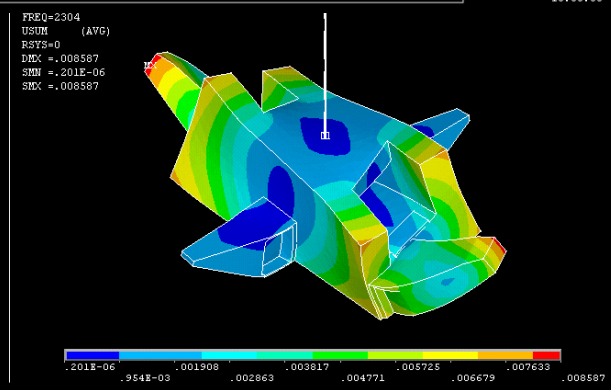

# FEM thermal simulation

- define the diameter of the copper suspension wires;
- draw the expected equilibrium temperature when there is a laser light on the mirror

## The model

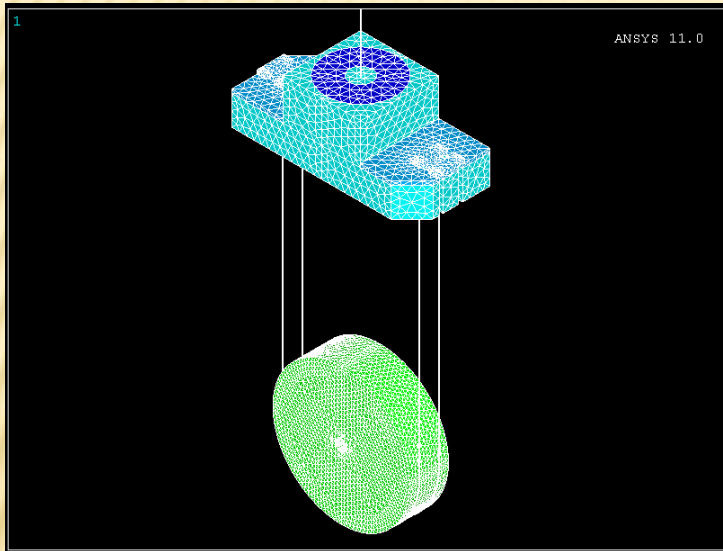

- The reaction masses are not present in the simulation;
- Their screen effect is simulated by the surround system at 10K;
- The marionetta arms are not present.
- Copper and silicon thermal properties vs temperature are included in the simulation.

- The mirror and marionette reaction mass will lengthen the overall cooling time;

## Boundary Conditions

### •Cryocooler Second stage link to the marionetta

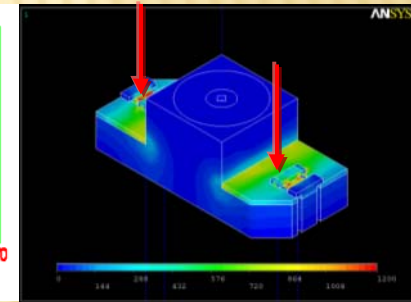
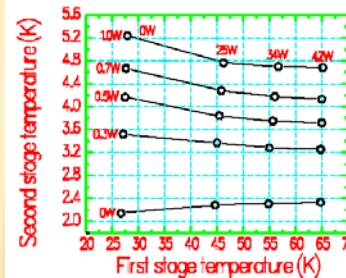

$P_{\text{cooler}}$  depends on the temperature (Cryomec PT curve used)

### •Laser power on the mirror

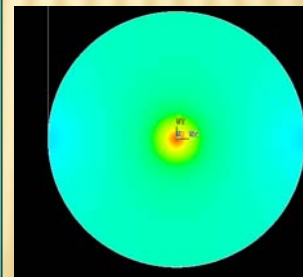

Gaussian beam

$$P_{\text{abs}} = 1 \text{ W}$$

$P_{\text{abs}} = 100 \text{ mW}$  by the mirror bulk

The power absorbed by the coating is dominant

Starting point:

- thermalised system at 10 K
- laser power on
- surrounding system at 10K

# FEM thermal simulation

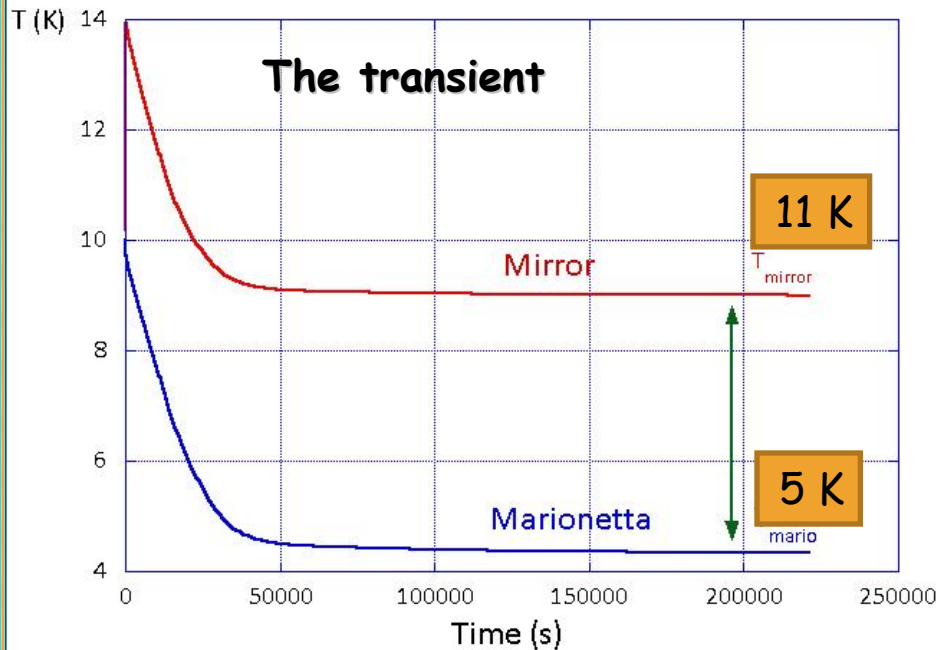

• For a wire diameter of 3.0mm.

## Steady state Mirror temperature

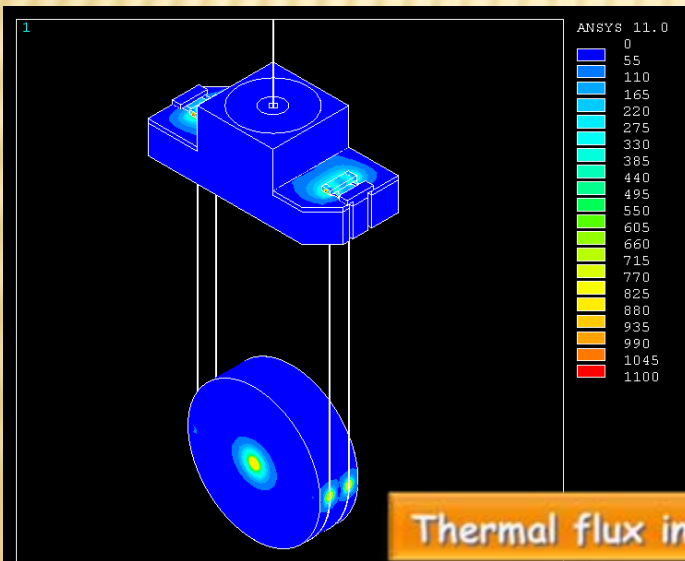
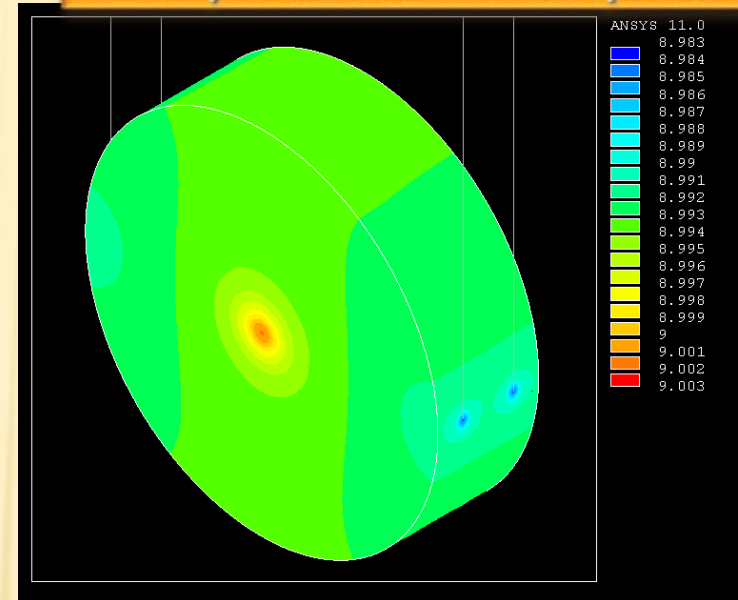

Thermal flux in the steady state

$$P_{cooler}(T_{mario}) = P_{abs} = 1 \text{ W} \Rightarrow T_{mario} = 5 \text{ K}$$

$$P_{abs} = 4 \frac{\sum_w}{L} K_{mean} (T_{mario} - T_{mirror})$$

$$K_{mean} = \frac{1}{\Delta T} \int_{T_{mario}}^{T_{mirror}} K_{copper}(T) dT \cong 16000 \frac{\text{W}}{\text{m} \cdot \text{K}}$$

$$\Rightarrow T_{mirror} = 11 \text{ K}$$

G0900642-v1

# The Cryogenic Test Facility

F. FRASCONI, R. PASSAQUIETI (PISA) A. PASQUALETTI, (EGO)

- × Cryostat built in Cascina (Virgo site - 1500 West Arm)
- × Equipped with 2 pulse tube cryogenerators (1 double-stage (0.5W @ 4.5 K), 1 single stage PT60)

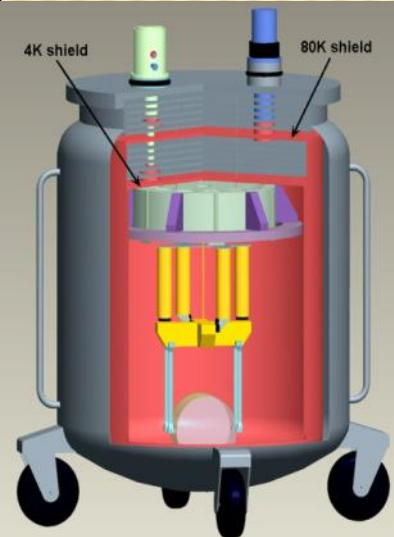

# A SKETCH OF CRYO-PAYLOAD

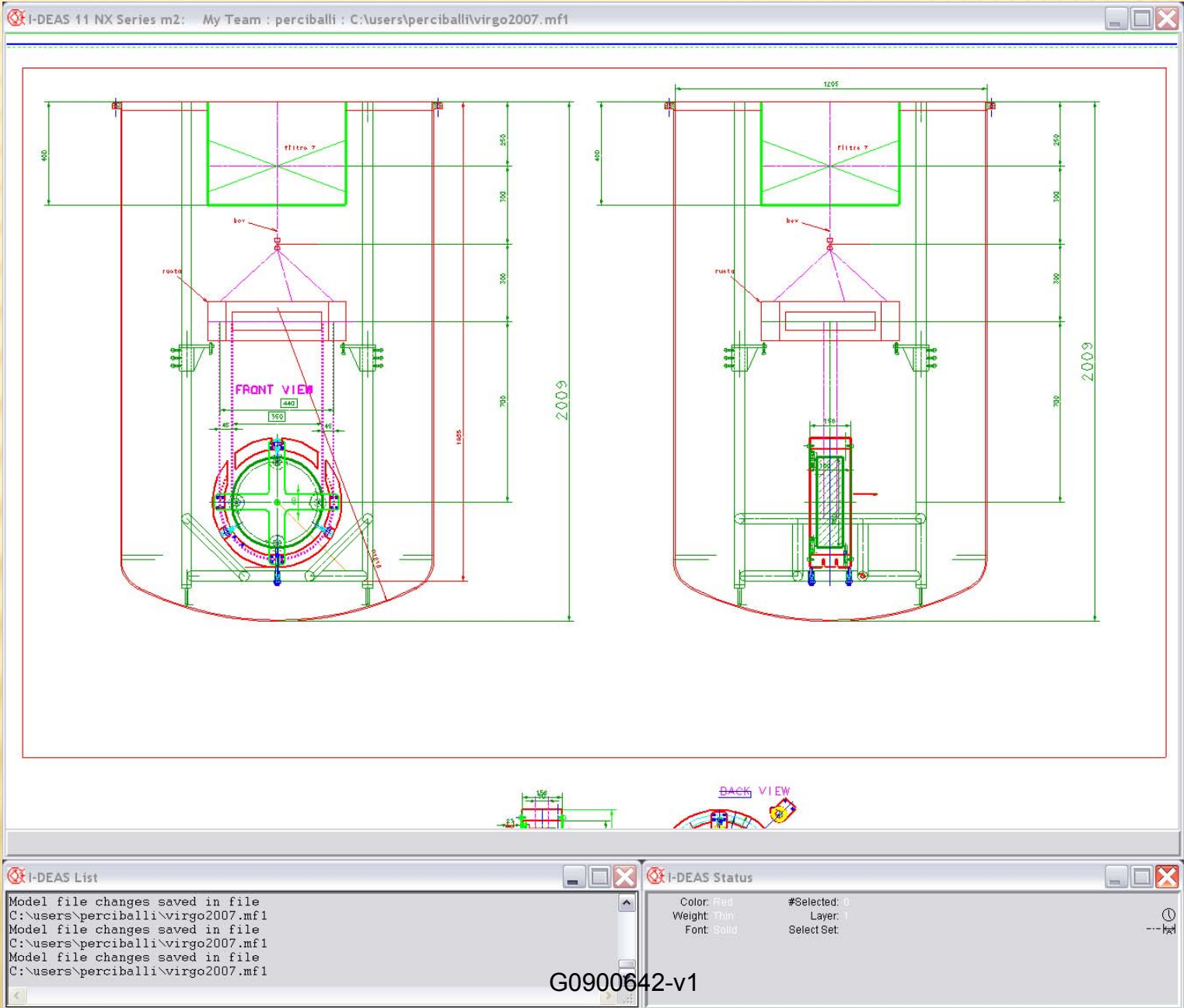

# THE “CRYO LAST STAGE”

## Set-up:

- Silicon mirror suspended by using two Be-Cu wires loops (1.25mmX2.5mm section);
- Marionette with copper clamps, connected to the cooler by copper heat links, suspended with a titanium alloy cable;
- Reaction mass of the mirror and marionette position monitored with fiber bundle sensors to measure the system modes (suspended with copper wires);
- Reaction mass of the marionette holding the Virgo-like electromagnetic actuators (macor support, copper wire kapton insulated);
- MRM suspended with three titanium wires;





# MARIONETTA RM AND MIRROR RM



Suspension System of the payload and MRM

Silicon Mirror and its RM

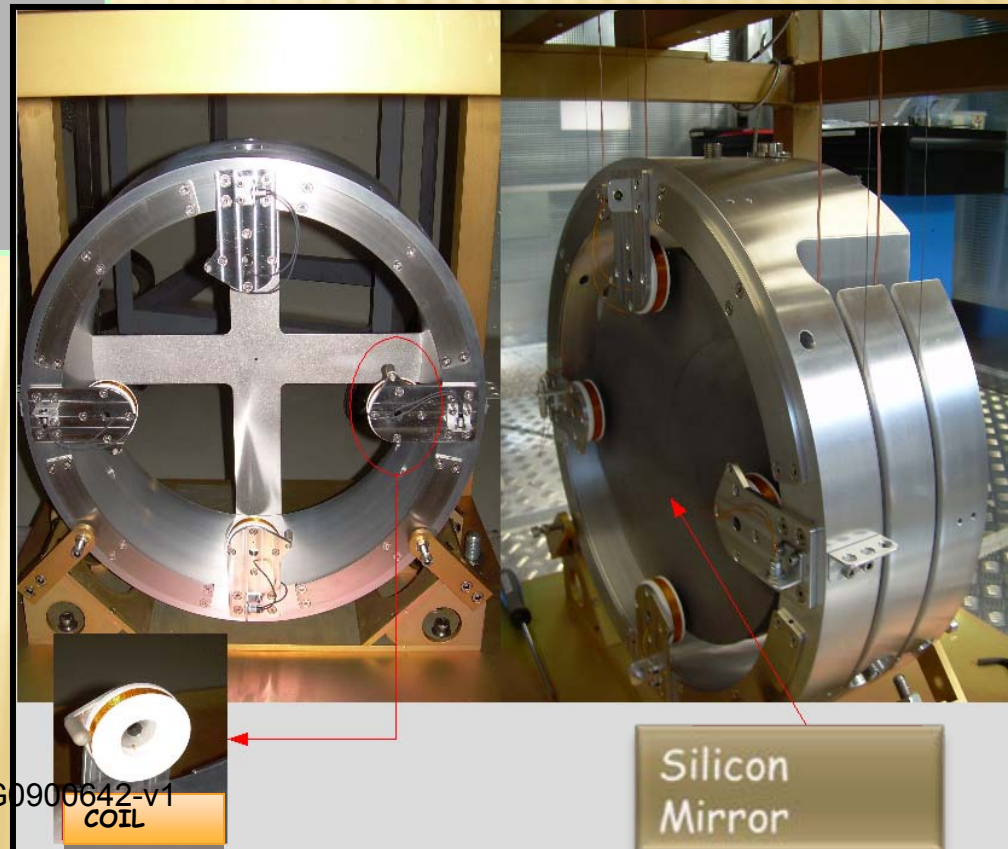

G0900642-v1  
COIL

Silicon  
Mirror

# THERMAL LINKS



On the marionette

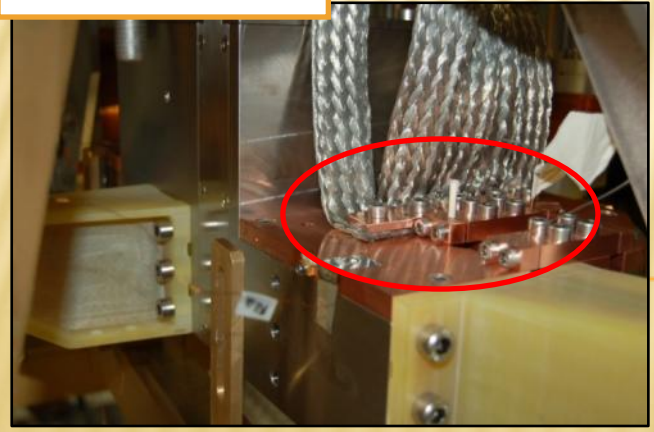

# FIBER BUNDLE SENSORS

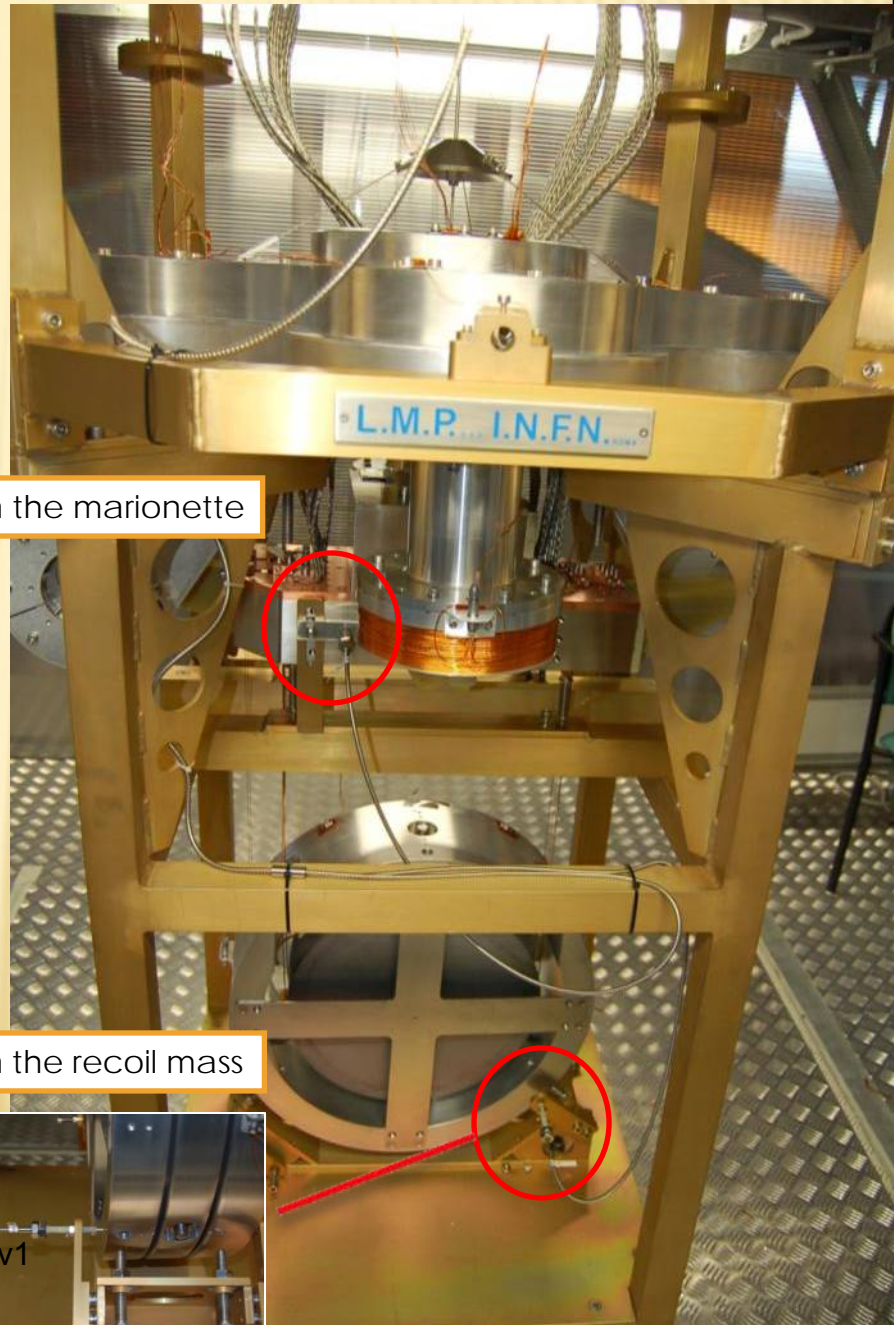

Fiber bundle on the marionette

Fiber bundle on the recoil mass

G0900642-v1

# STUDY OF THE MECHANICAL BEHAVIOR (I)

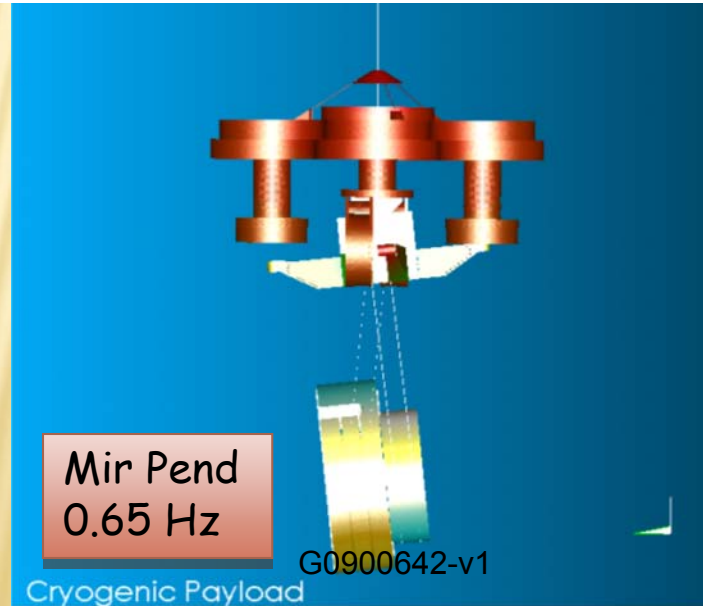
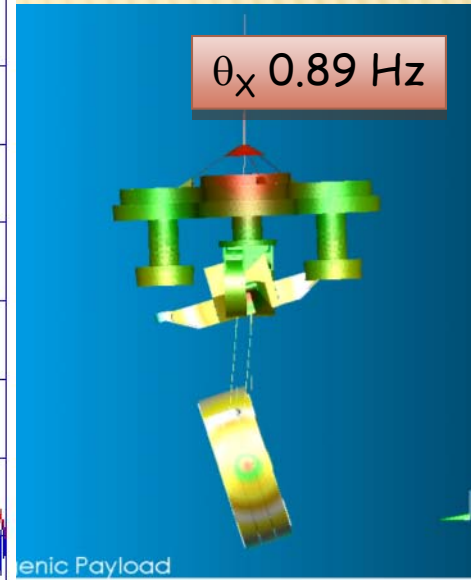
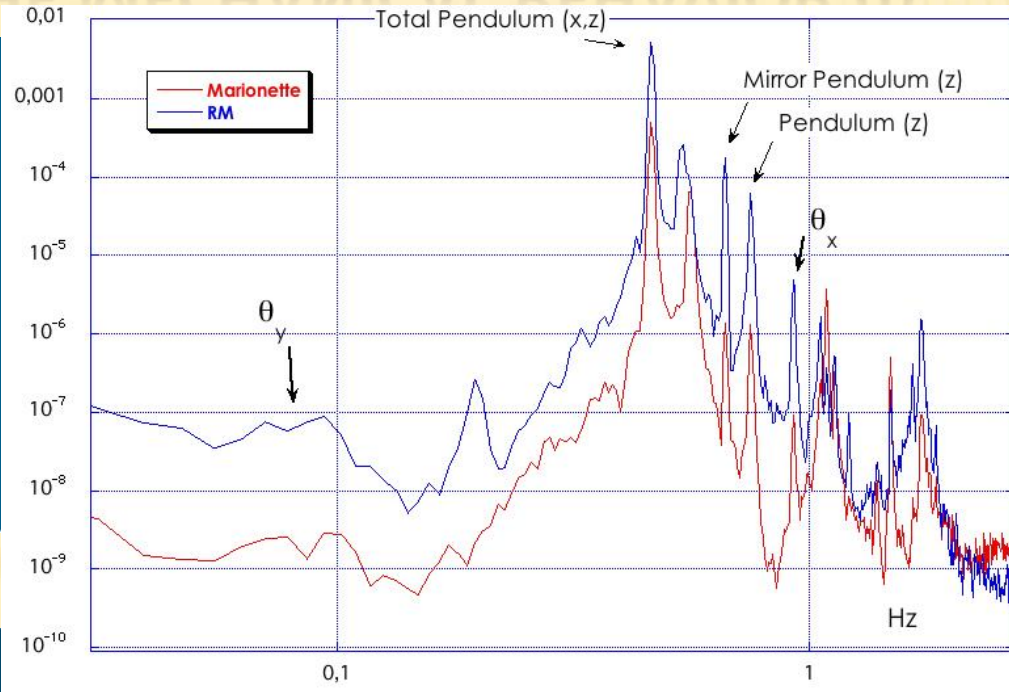

# STUDY OF THE MECHANICAL BEHAVIOR (II)

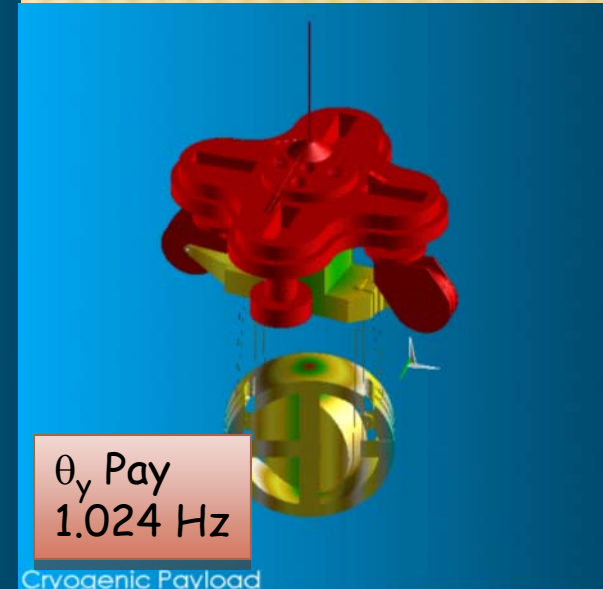
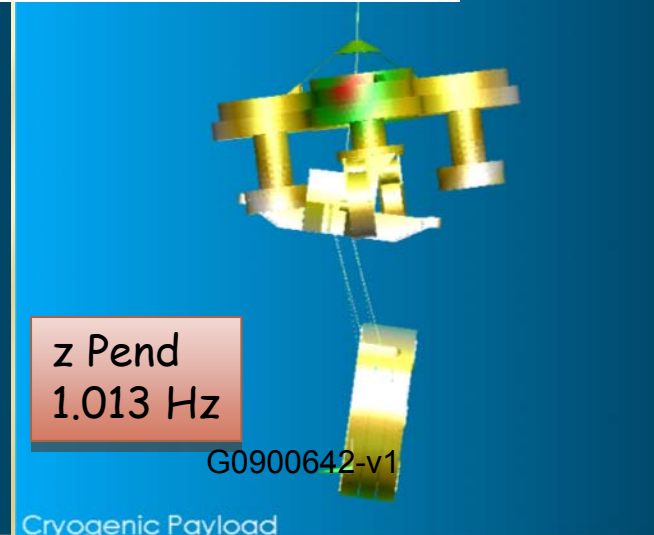
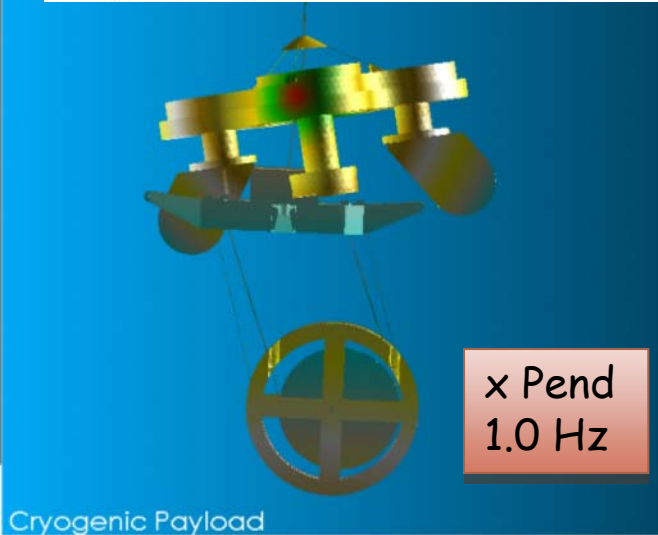
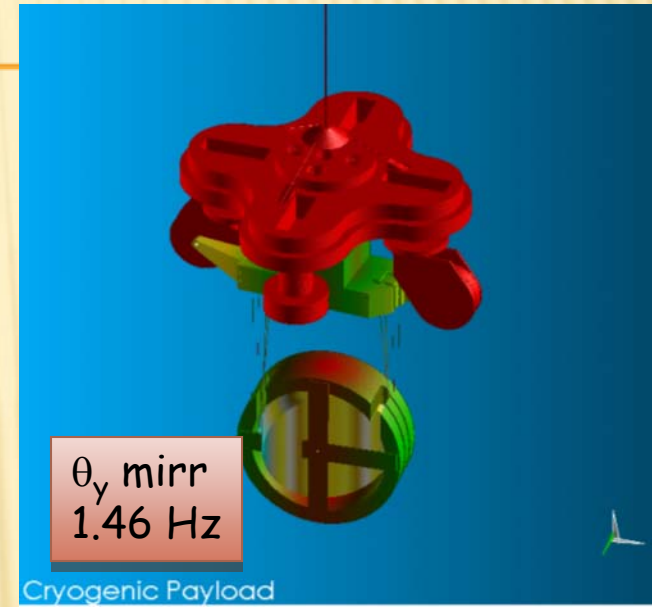
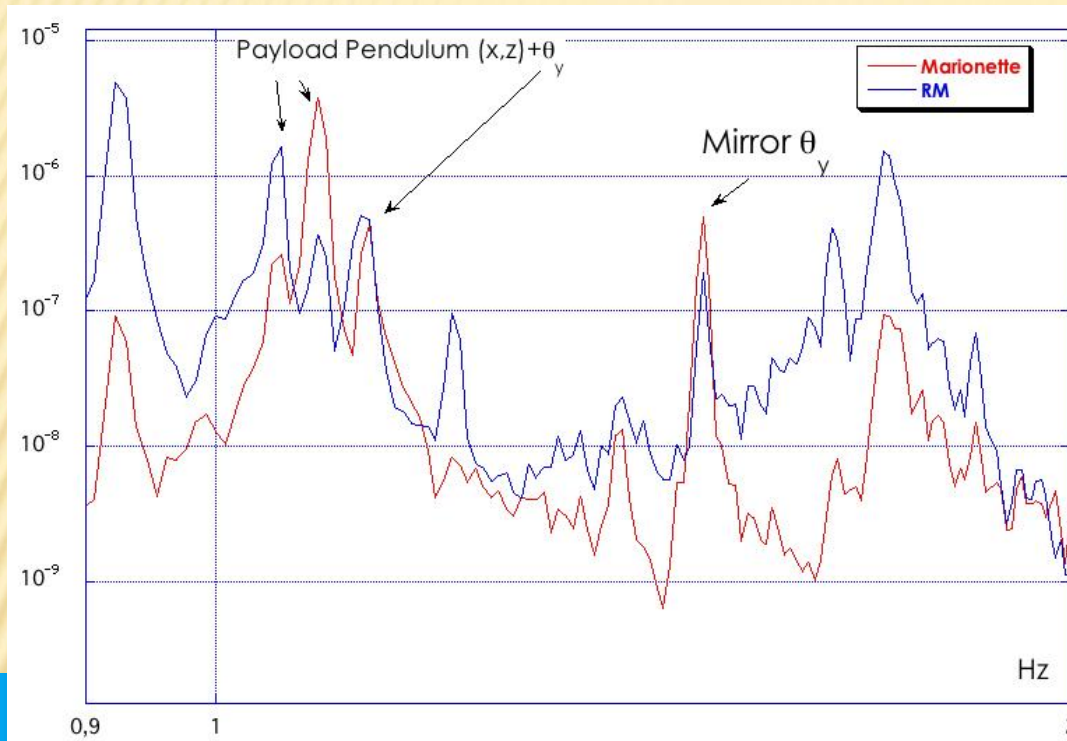

# THE SYSTEM INSERTED IN THE CRYOSTAT (ON VIRGO SITE 1500WA)

READY FOR INSERTION

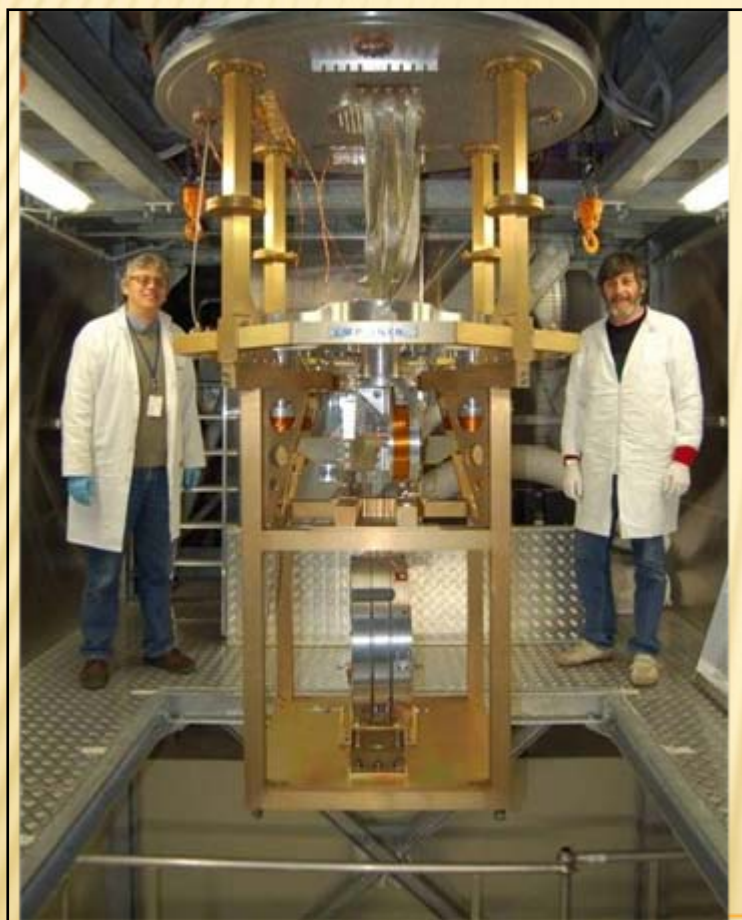

CLOSED VACUUM CHAMBER



# FIRST PAYLOAD COOLING RUN (JANUARY 5<sup>TH</sup> 2009)

During the cooling several times the PT cryo-coolers were stoppes, because of failure in the water refrigeration system of the compressors.

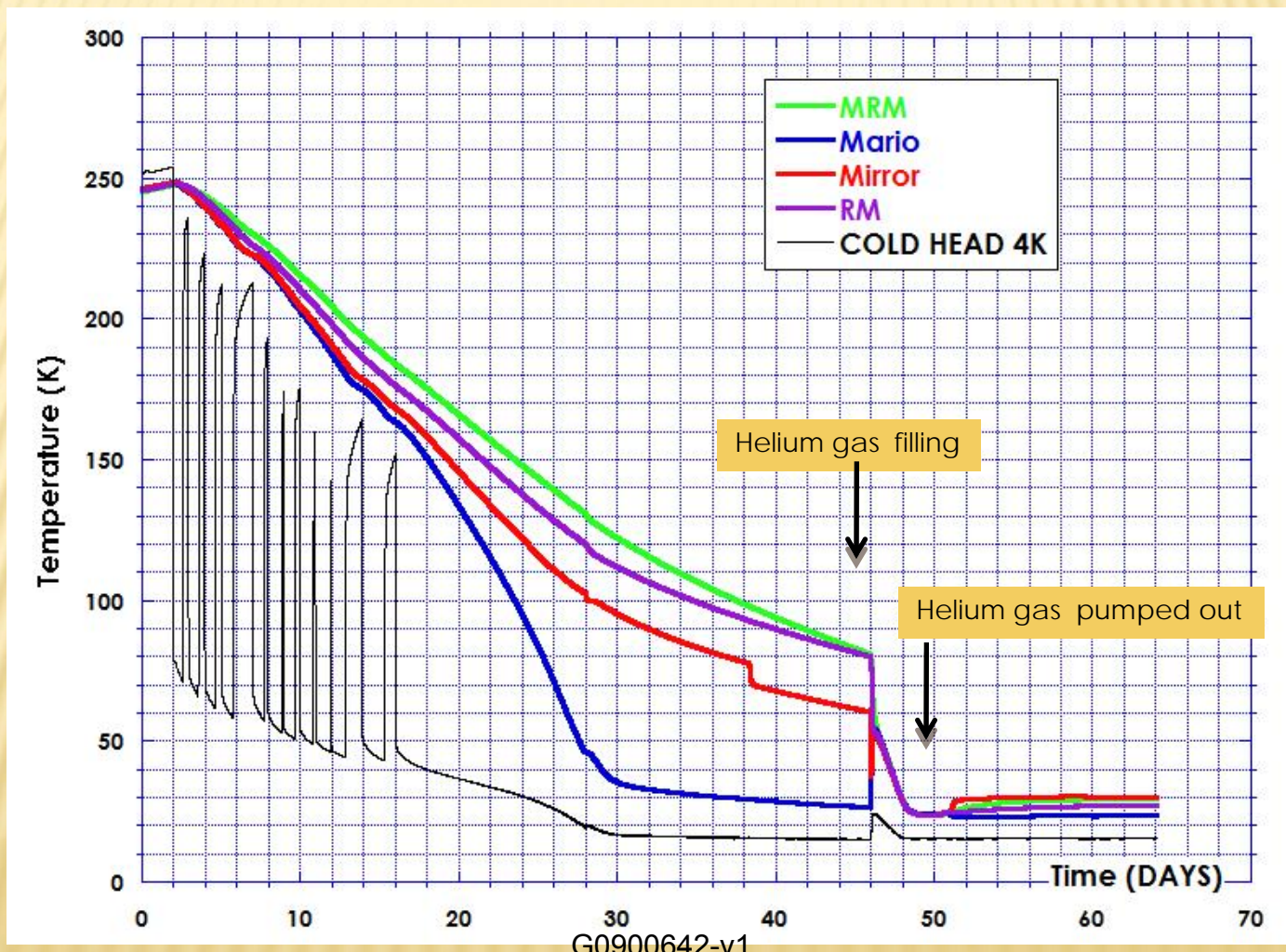

The final mirror temperature results to be 30 K while the cold head is at 15 K.

# THERMAL INPUTS ESTIMATIONS

6/25/2009

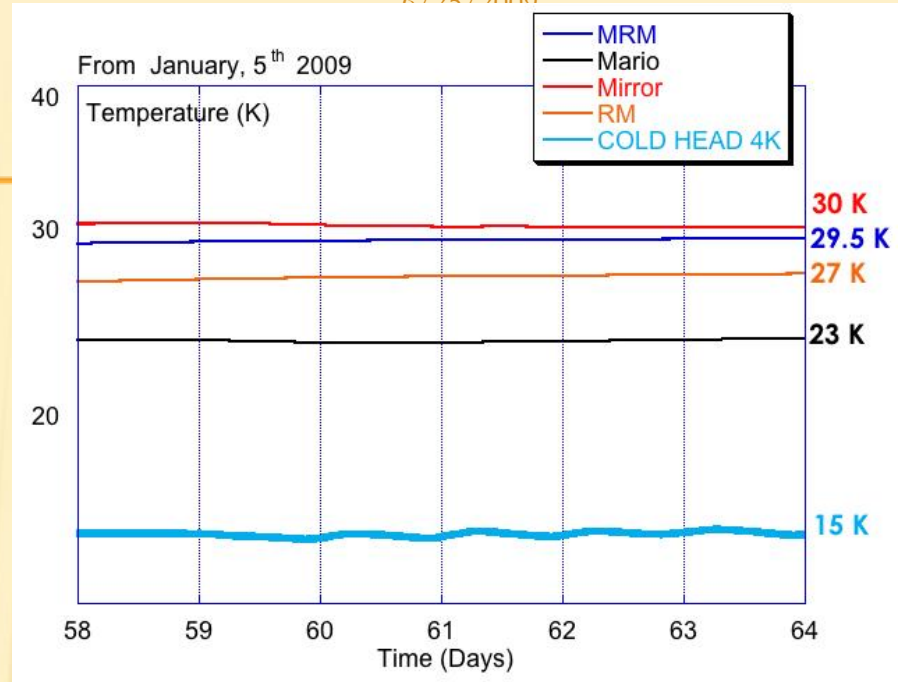

- ✘ **Mirror: 1.9 mW (CoBe3 wires)**
- ✘ **Recoil Mass: 1 mW (Steel c70 wires)**
- ✘ **Marionette: 6 mW (Ti6Al4 wires)**
  
- ✘ Most of the thermal power (>10W) is lost in the cooling process of the whole cryostat;
- ✘ Improvement of the thermal overall insulation is needed;

# DISPLACEMENT SPECTRA

Room Temperature: Pulse Tubes OFF

Pulse Tubes ON



Room temperature  
Displacement spectra of the marionette and mirror reference mass

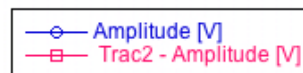
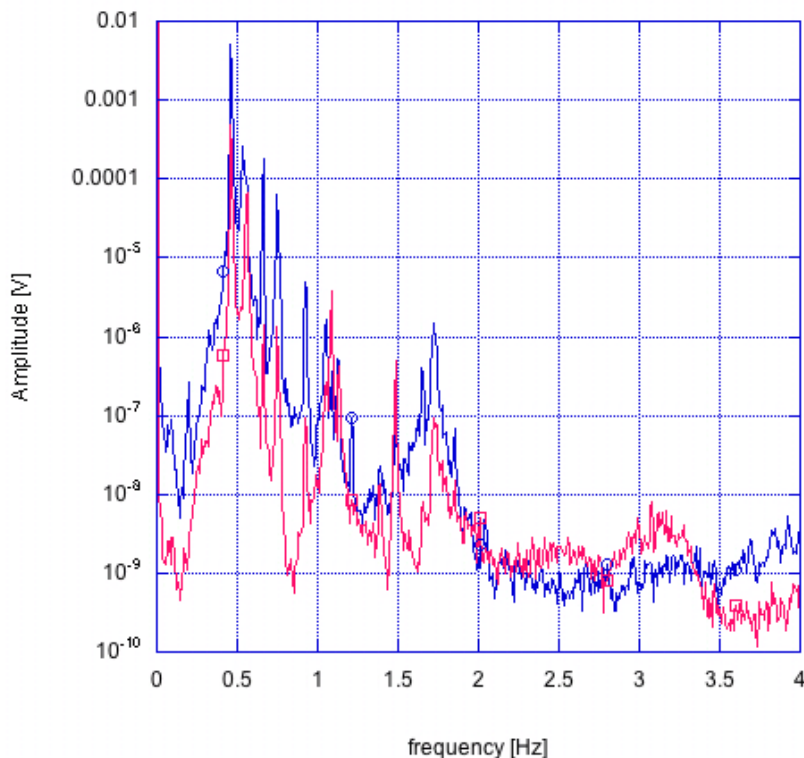

126 K mirror temperature  
Displacement spectra of the marionette and mirror reference mass

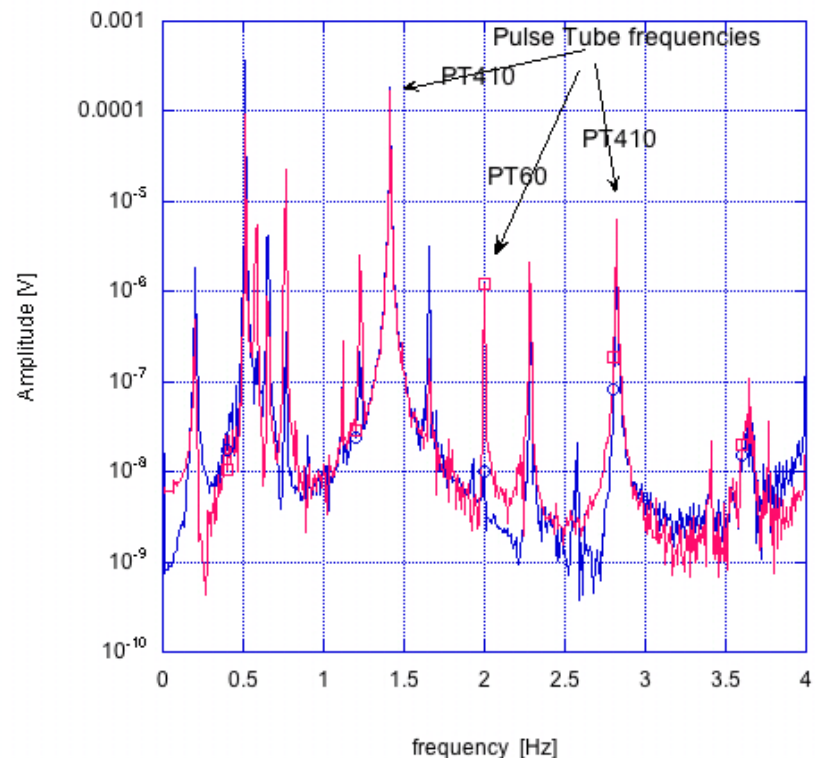



# COMPARISON BETWEEN HOT AND COLD PAYLOAD

PT410 Harmonics: 1.412 Hz, 2.824 Hz, 4.236 Hz, 5.641 Hz, 7.060 Hz, 8.8472 Hz

PT60 Harmonics: 2 Hz, 4 Hz, 6 Hz, 8 Hz

Frequency Hot	Frequency Cold	Simulation (without copper heat links)	Mode
	26.4 mHz	54 mHz	$\Theta_y$
93.75 mHz	71 mHz	87mHz	$\Theta_y$
197.7 mHz	200 mHz	0.467 Hz	z
0.4598 Hz	0.510 Hz	0.477 Hz	x
0.536 Hz	0.58 Hz	0.59 Hz	$\Theta_z$
0.554 Hz	0.643 Hz	0.653 Hz	x
0.66 Hz	0.754 Hz	0.68 Hz	z
0.75 Hz	0.763 Hz	0.71 Hz	x
0.924 Hz	0.974 Hz	0.74 Hz	z
1.050 Hz	1.021 Hz	0.893 Hz	$\Theta_x$
1.087 Hz	1.092 Hz	0.995 Hz	z
1.126 Hz	1.122 Hz	1.013 Hz	x
1.485 Hz	1.163 Hz	1.024 Hz	$\Theta_y$
1.65 Hz	1.228 Hz	1.455 Hz	$\Theta_y$
1.724 Hz	2.23 Hz	2.136 Hz	$\Theta_z$
1.85 Hz	2.288 Hz	2.271 Hz	$\Theta_x$
2.04 Hz	2.323 Hz	3.972 Hz	$\Theta_x$
3.83 Hz	3.7 Hz (wide)		
	4.421 Hz		

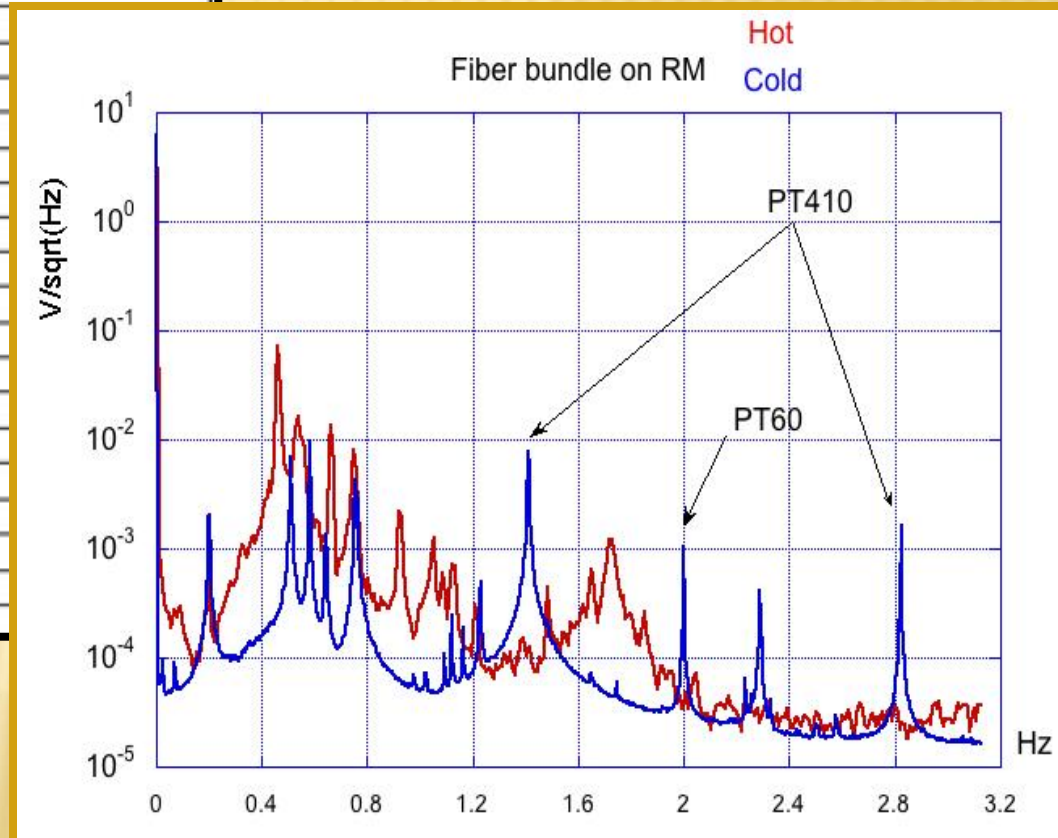

G0900642-v1

# STATUS AND NEXT STEPS OF THE LAST STAGE CRYOGENIC PAYLOAD

## Present

- ▣ The last stage cryogenic payload was characterized mechanically
- ▣ First cooling run finished:  $T_{\text{mirror}}=30\text{K}$ ;
- ▣ Most of the thermal power ( $>10\text{W}$ ) is lost in the cooling process of the whole cryostat;

## Very Near Future

- ▣ *Improvement of the design of the cryo payload and its cooling system*