

Title		
Common Mode Board		
Size	Number	Revision
B	D040180	F
Date:	3/15/2013	Sheet 1 of 17
File:	D:\Users\...\CM0.SchDoc	Drawn By: Daniel Sigg

For small input signals add gain to these instrumentation amplifier stages.

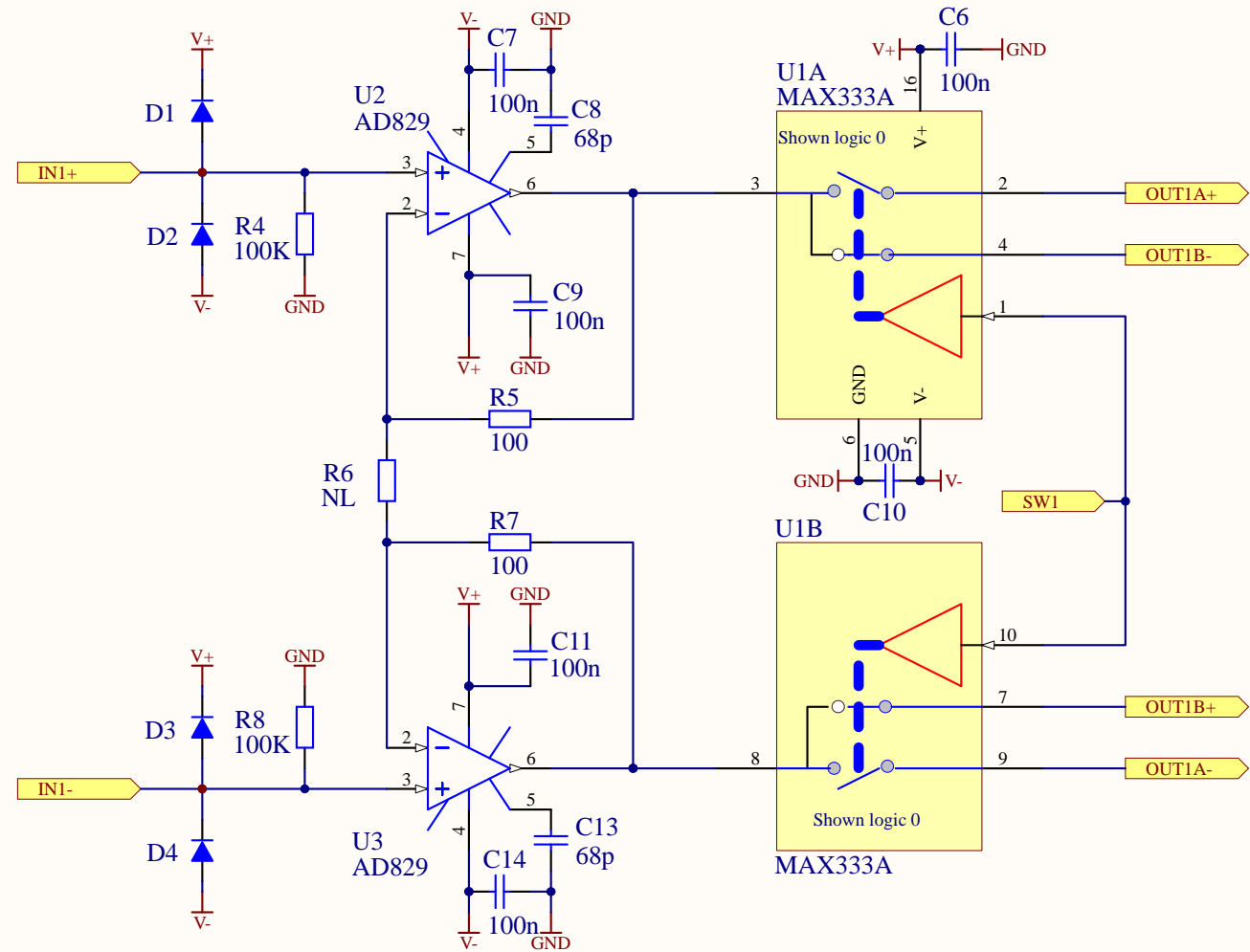

Title		
Common Mode Board: Input		
Size	Number	Revision
B	D040180	F
Date:	3/15/2013	Sheet 2 of 17
File:	D:\Users\...\CM1.SchDoc	Drawn By: Daniel Sigg

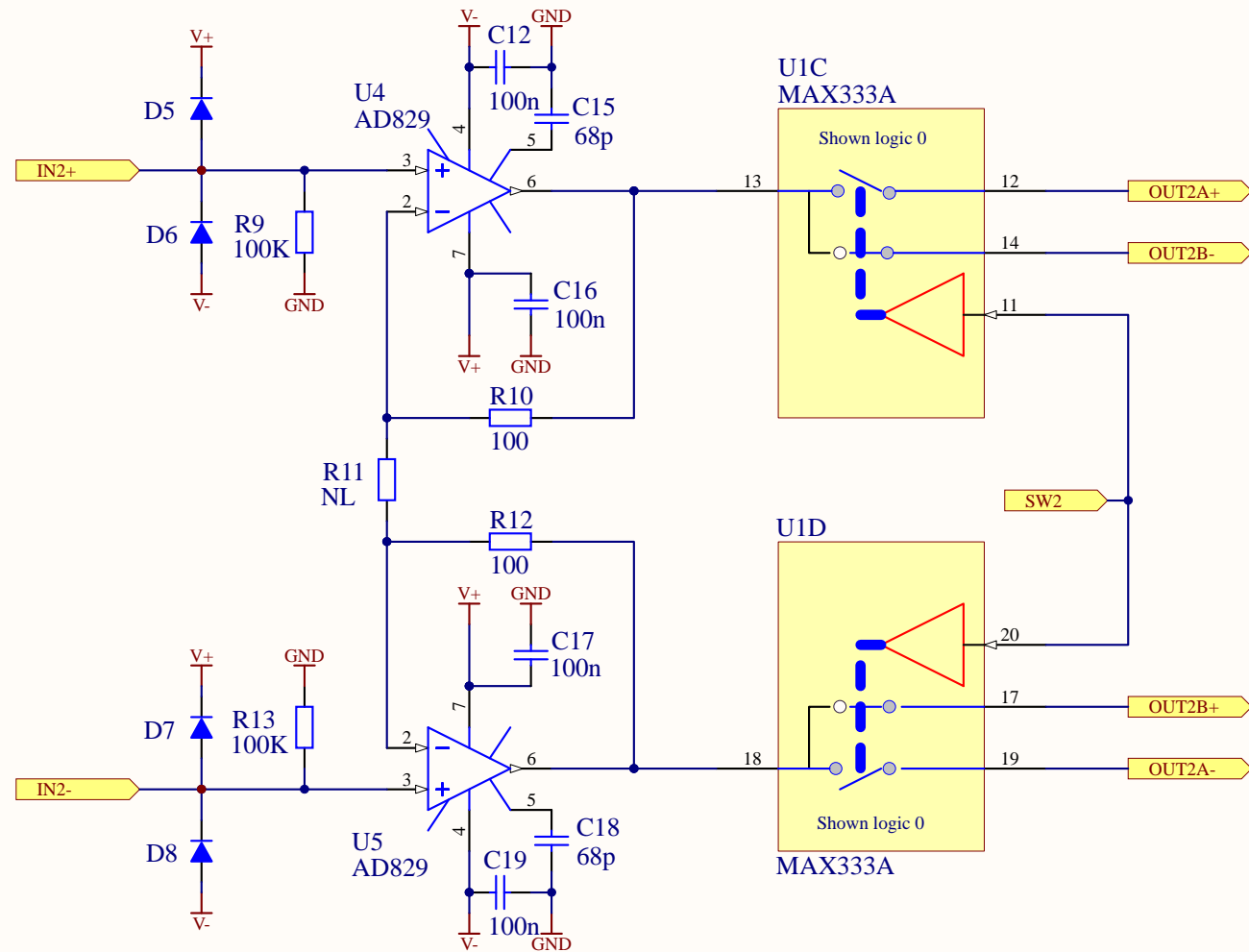
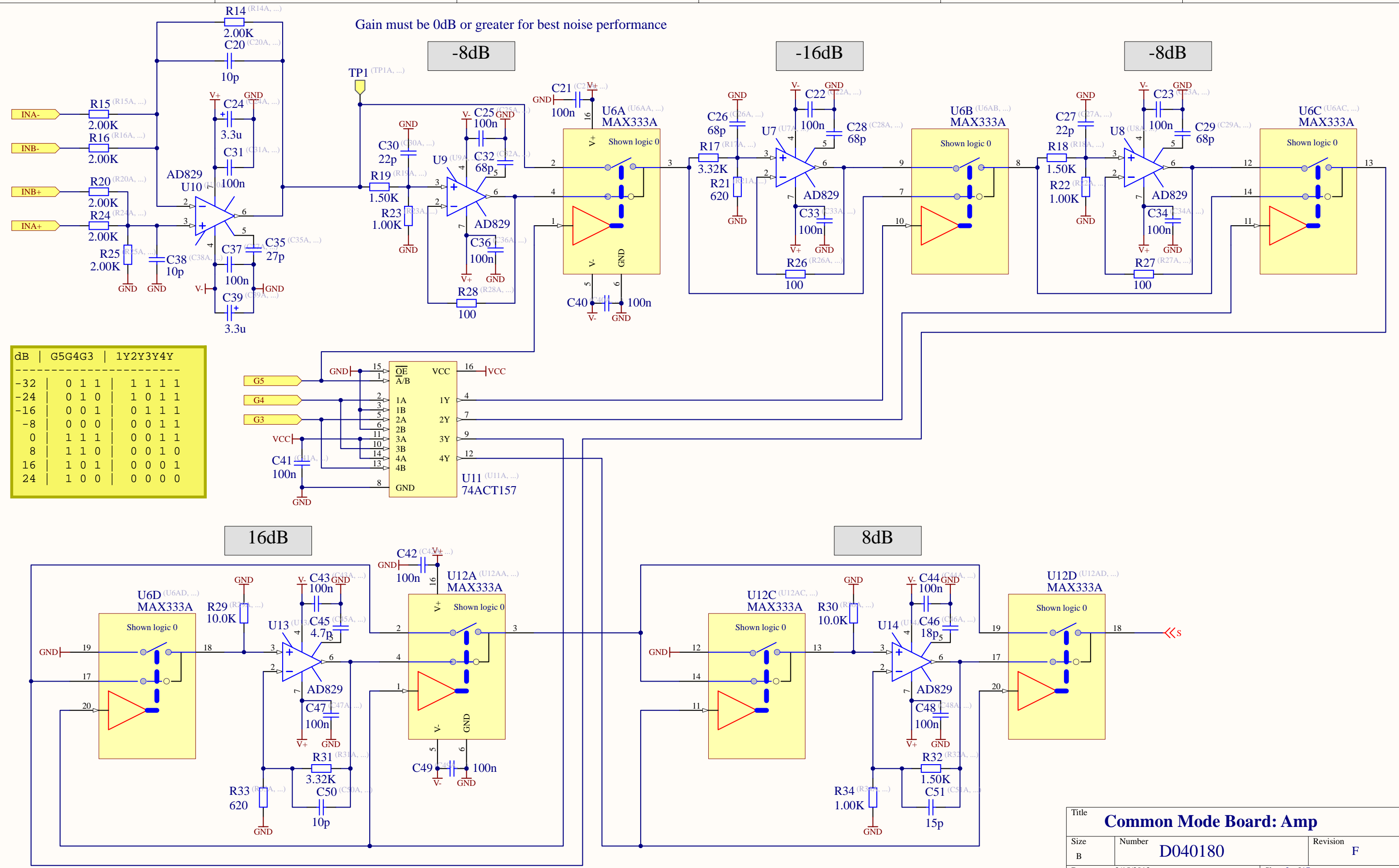

Title		
Common Mode Board: Amp		
Size	Number	Revision
B	D040180	F
Date:	3/15/2013	Sheet 3 of 17
File:	D:\Users\...\CM2A.SchDoc	Drawn By: Daniel Sigg

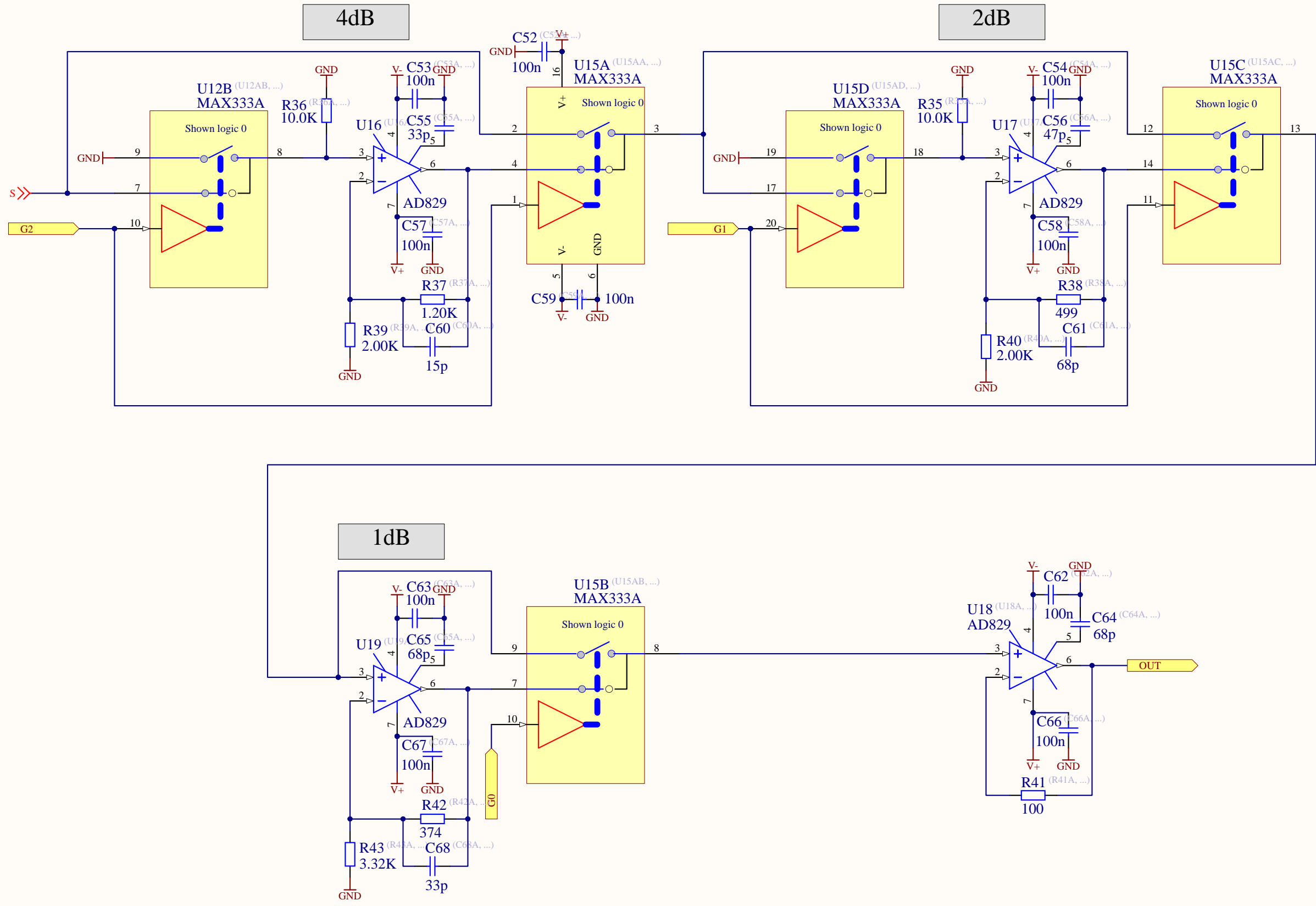

Title			Common Mode Board: Amp		
Size	Number	Revision			
B	D040180	F			
Date:	3/15/2013	Sheet 4 of 17			
File:	D:\Users\...\CM2B.SchDoc	Drawn By: Daniel Sigg			

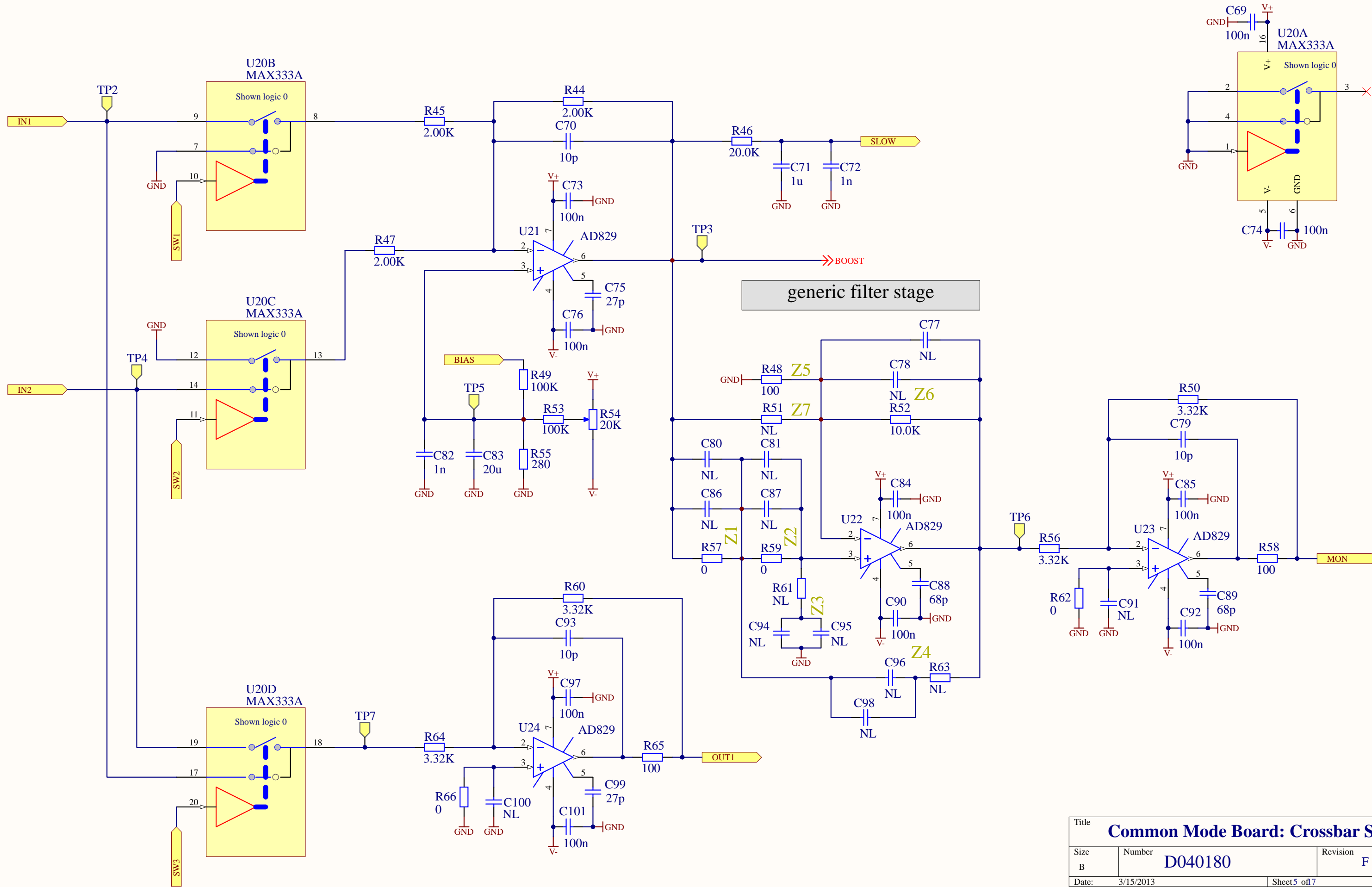

Title		
Common Mode Board: Crossbar Switch		
Size	Number	Revision
B	D040180	F
Date:	3/15/2013	Sheet 5 of 7
File:	D:\Users\...\CM3A.SchDoc	Drawn By: Daniel Sigg

40Hz/4kHz pole/zero pair

1kHz/20kHz pole/zero pair

1kHz/20kHz pole/zero pair

300Hz/4.5kHz pole/zero pair

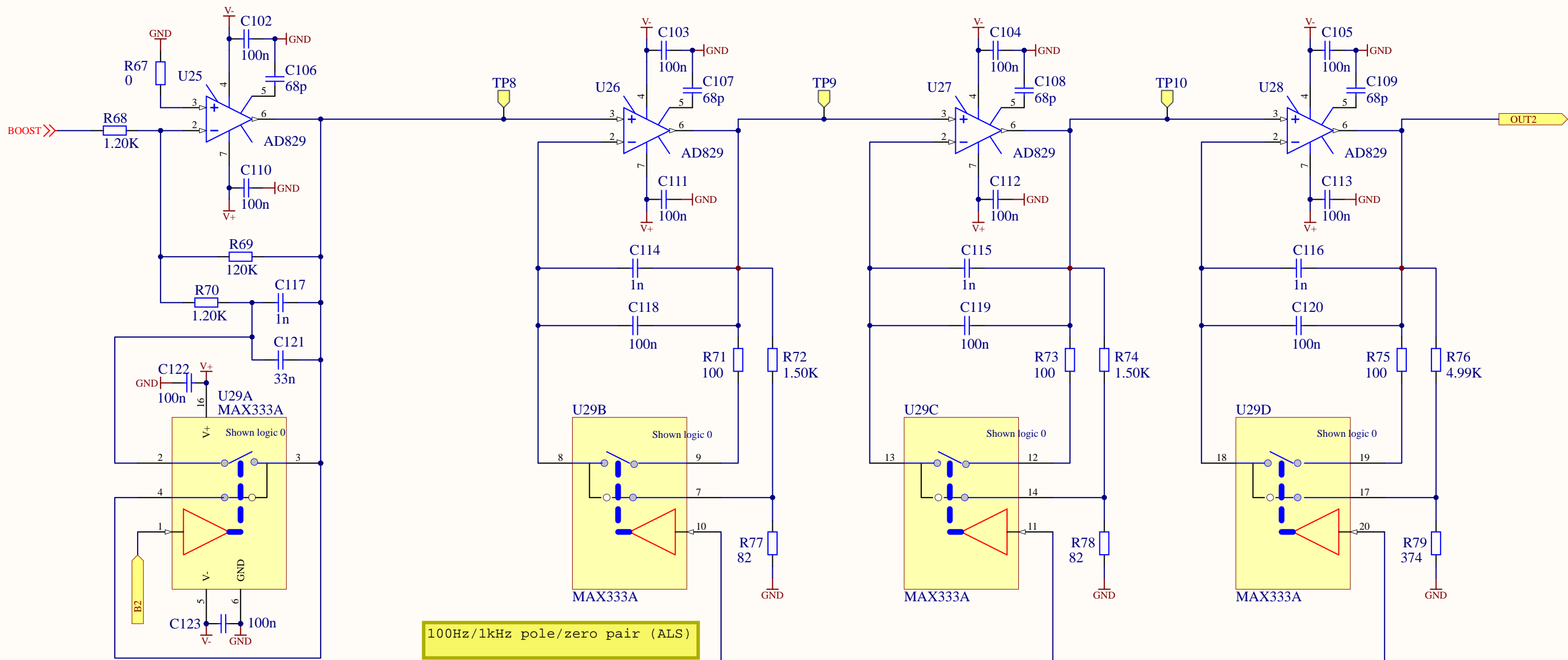

1.35Hz/4kHz pole/zero pair (LL)

40Hz/200Hz pole/zero pair (ALS)

100Hz/1kHz pole/zero pair (ALS)

Boosts	B1B0	1Y2Y3Y
0	1 1	1 1 1
1	1 0	0 1 1
2	0 1	0 0 1
3	0 0	0 0 0

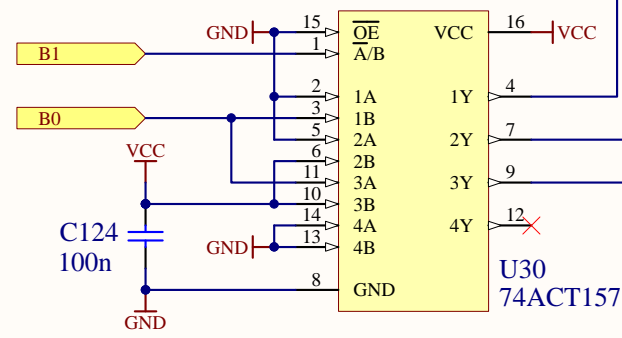

Title Common Mode Board: Boost		
Size B	Number D040180	Revision F
Date: 3/15/2013	Sheet 6 of 17	
File: D:\Users\...\CM3B.SchDoc	Drawn By: Daniel Sigg	

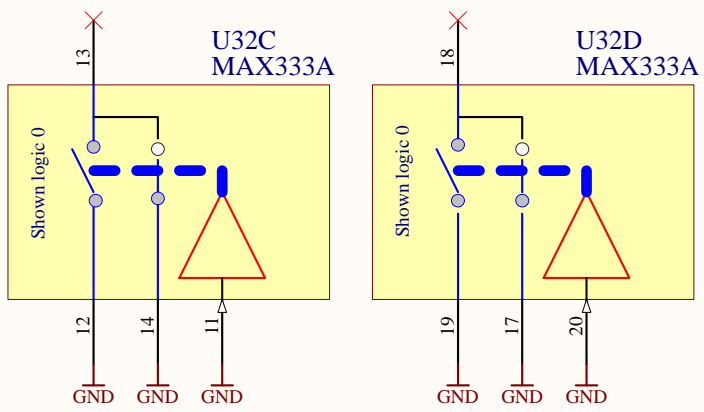
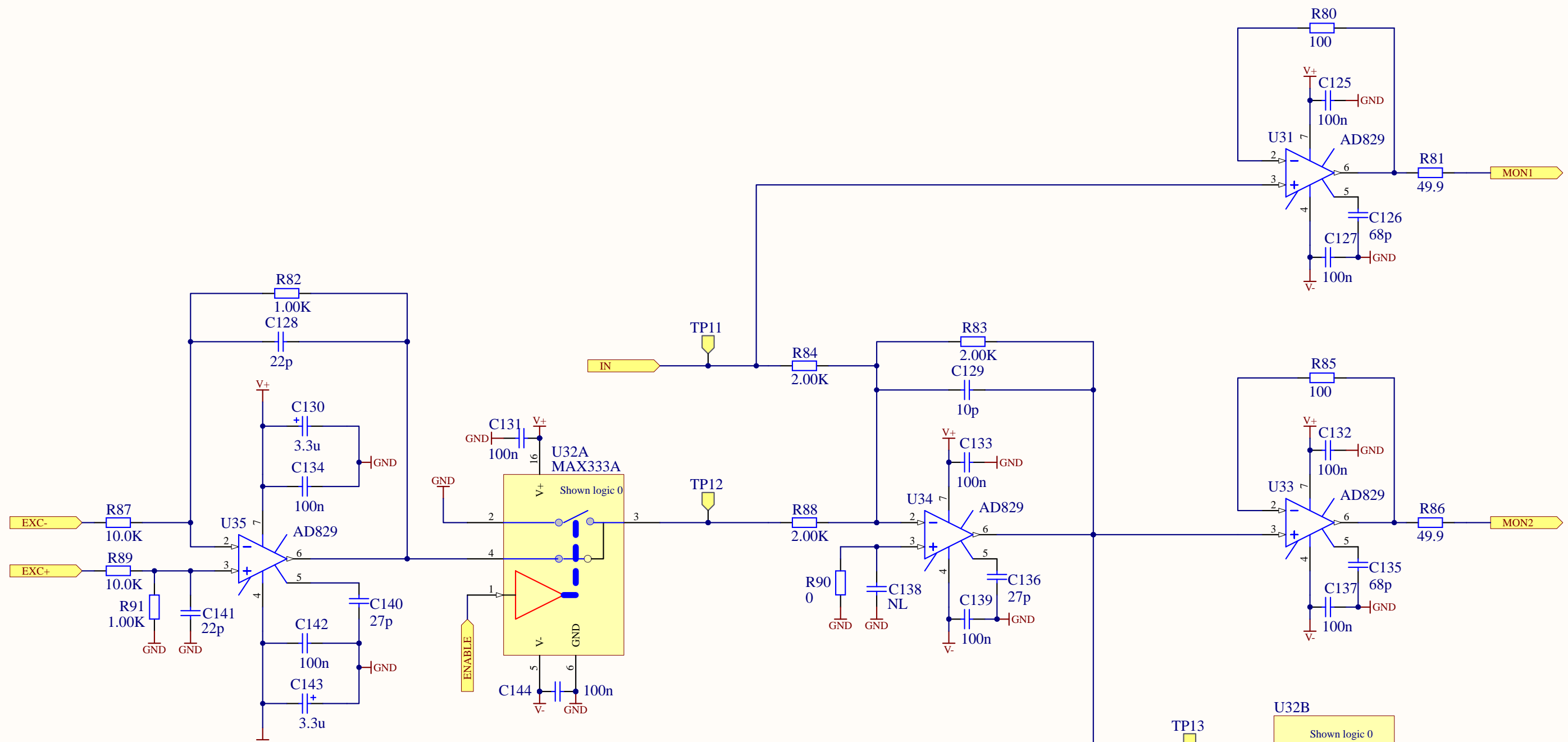

- M1 M3 standoff, 12mm
- M2 M3 pan, 8mm
- M3 M3 standoff, 12mm
- M4 M3 pan, 8mm
- M5 M3 standoff, 12mm
- M6 M3 pan, 8mm
- M7 M3 standoff, 12mm
- M8 M3 pan, 8mm
- M9 M3 standoff, 12mm
- M10 M3 pan, 8mm
- M11 M3 standoff, 12mm
- M12 M3 pan, 8mm
- M13 M3 pan, 8mm
- M14 M3 pan, 8mm
- M15 M3 pan, 8mm
- M16 M3 pan, 8mm
- M17 M3 pan, 8mm
- M18 M3 pan, 8mm
- McMaster-Carr 90317A115

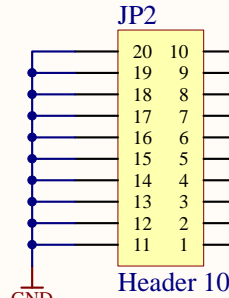
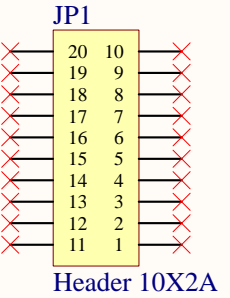

optional daughter board

Title Common Mode Board: Com. Excitation		
Size B	Number D040180	Revision F
Date: 3/15/2013	Sheet 7 of 17	
File: D:\Users\...\CM4A.SchDoc	Drawn By: Daniel Sigg	

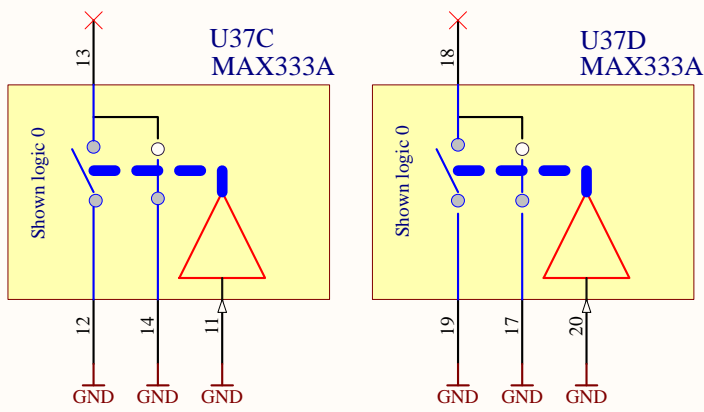
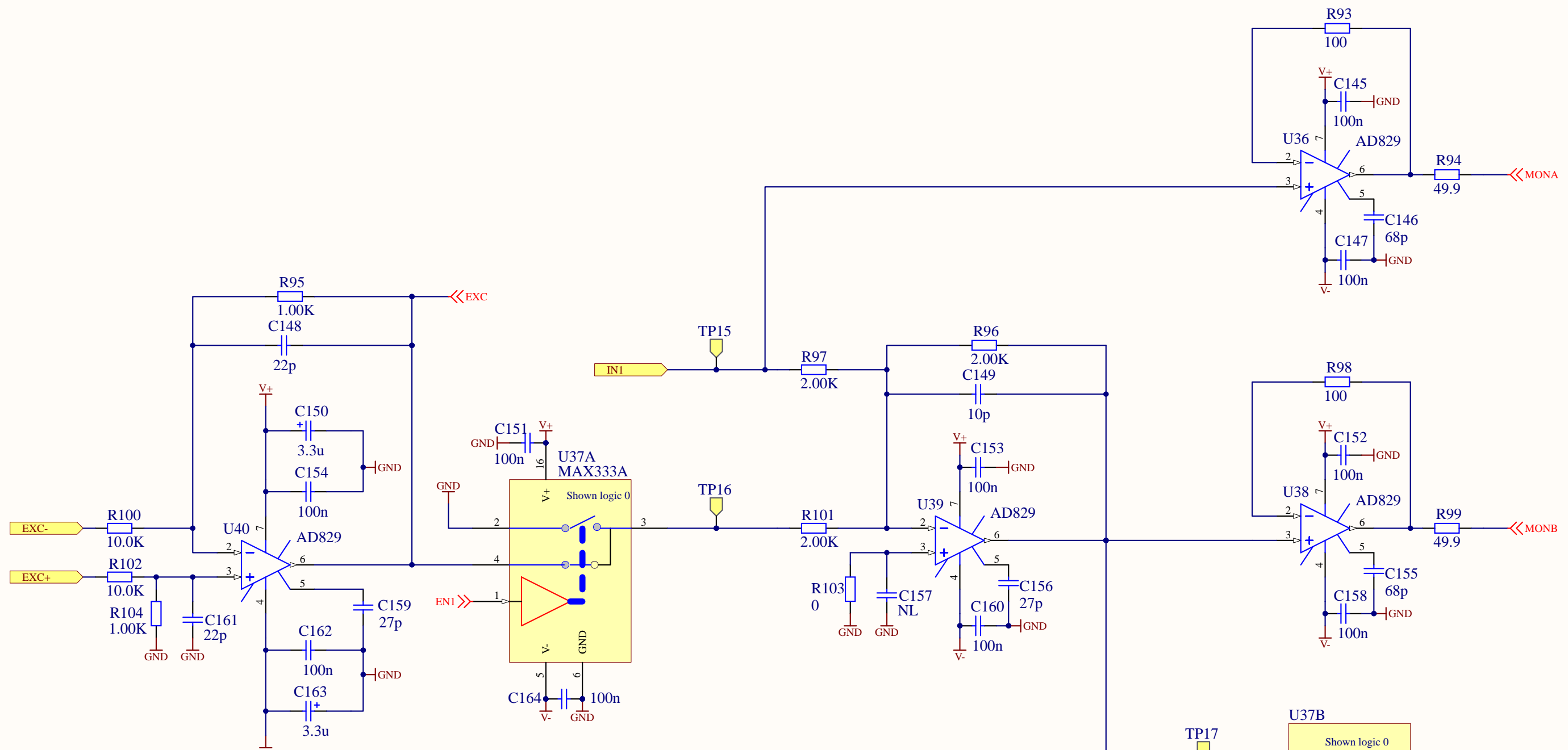

- M19 M3 standoff, 12mm
- M20 M3 pan, 8mm
- M21 M3 standoff, 12mm
- M22 M3 pan, 8mm
- M23 M3 standoff, 12mm
- M24 M3 pan, 8mm
- M25 M3 standoff, 12mm
- M26 M3 pan, 8mm
- M27 M3 standoff, 12mm
- M28 M3 pan, 8mm
- M29 M3 standoff, 12mm
- M30 M3 pan, 8mm
- Digi-Key 24434K-ND
- M31 M3 pan, 8mm
- M32 M3 pan, 8mm
- M33 M3 pan, 8mm
- M34 M3 pan, 8mm
- M35 M3 pan, 8mm
- M36 M3 pan, 8mm
- McMaster-Carr 90317A115

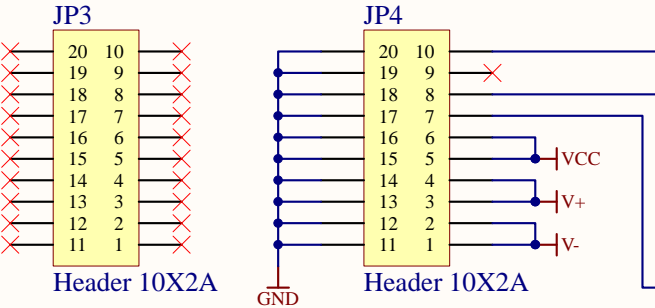

optional daughter board

Title Common Mode Board: Fast Excitation		
Size B	Number D040180	Revision F
Date: 3/15/2013	Sheet 8 of 17	
File: D:\Users\...\CM4B.SchDoc	Drawn By: Daniel Sigg	

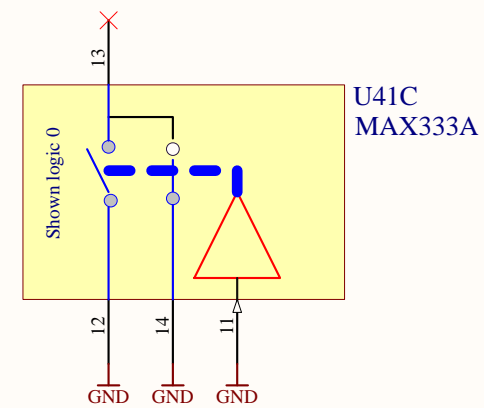
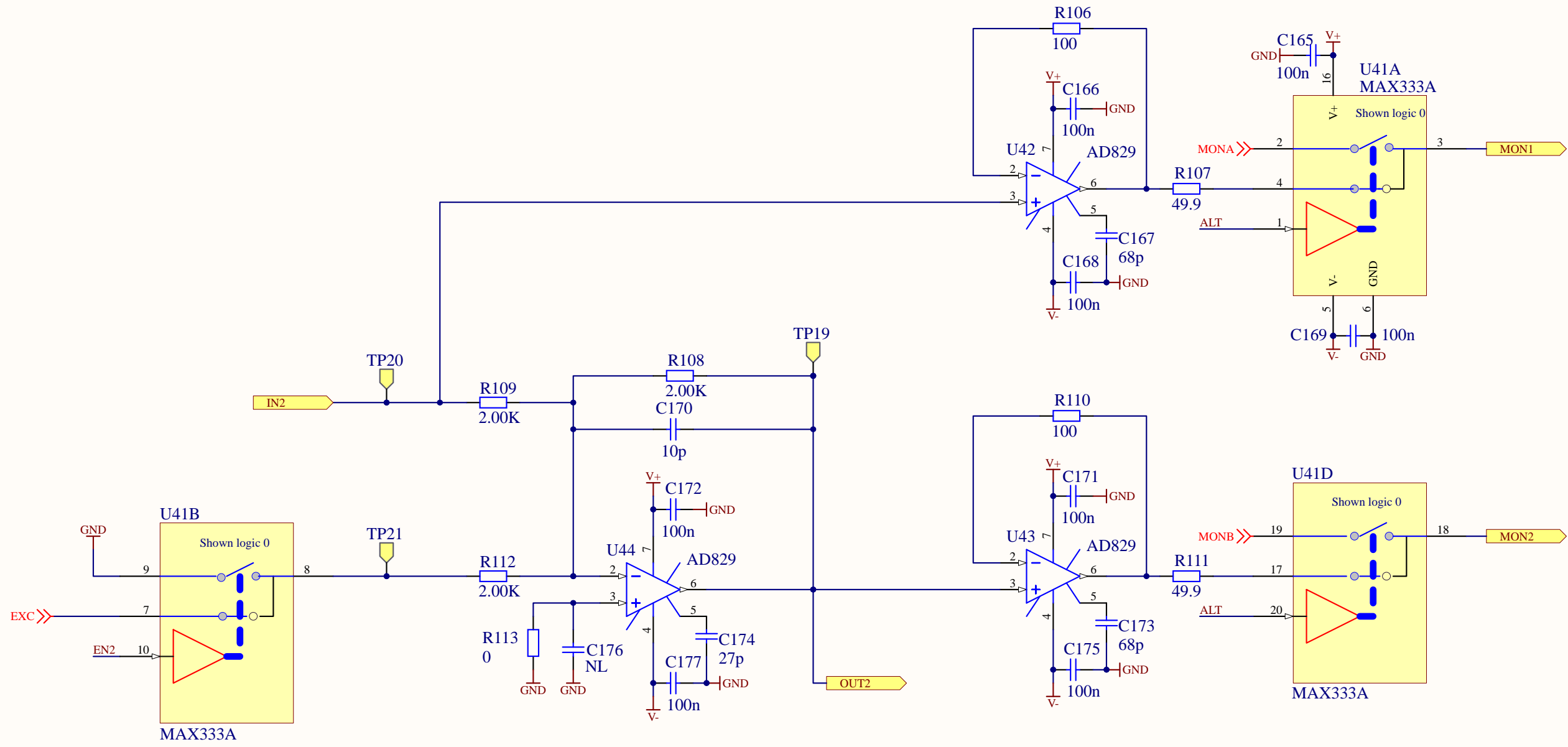

ENABLE	ALT	PATH	EN1	EN2
1	1	FAST	1	1
0	1	FAST	0	1
1	0	SLOW	1	1
0	0	SLOW	1	0

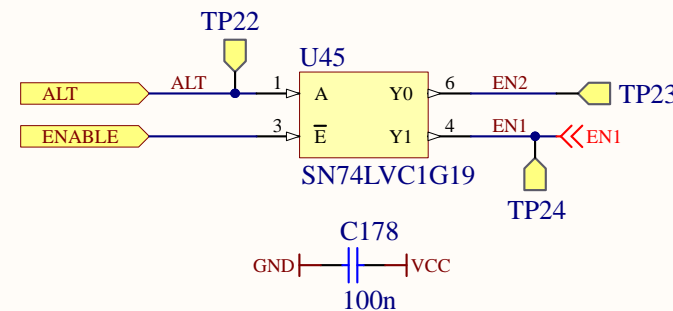

4kHz/17kHz pole/zero pair (MC):
 Z5: 374
 Z6: 33n || 1.2K

100kHz double pole/Q=0.85 (LL):
 Z1: 2.7K Z2: 1.3K
 Z3: 470p Z4: 1.5n
 Z6: 0

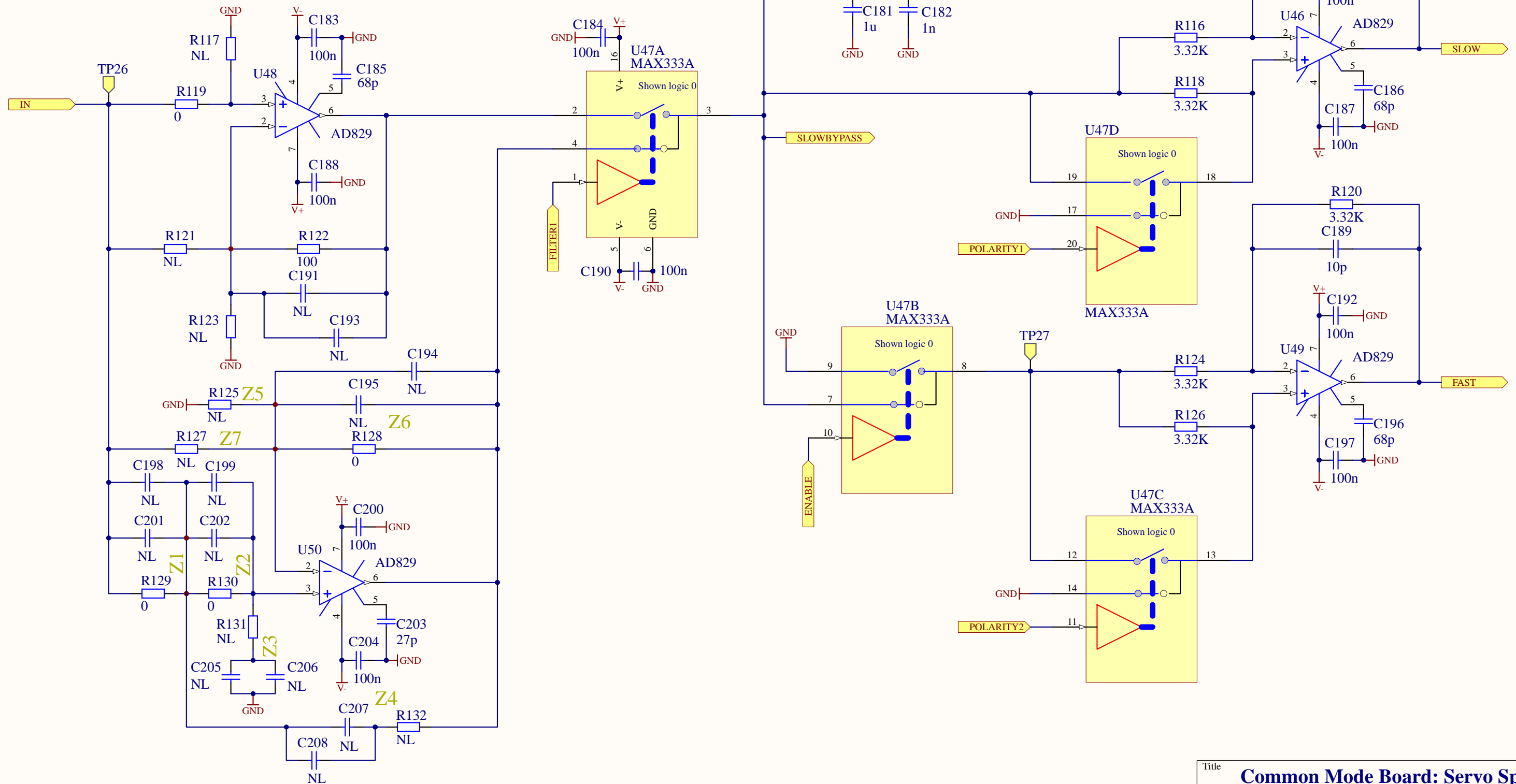

generic filter stage

Title		
Common Mode Board: Servo Split		
Size	Number	Revision
B	D040180	F
Date:	3/15/2013	Sheet10of17
File:	D:\Users\...\CM5A.SchDoc	Drawn By: Daniel Sigg

4Hz/400Hz pole/zero pair

4Hz pole

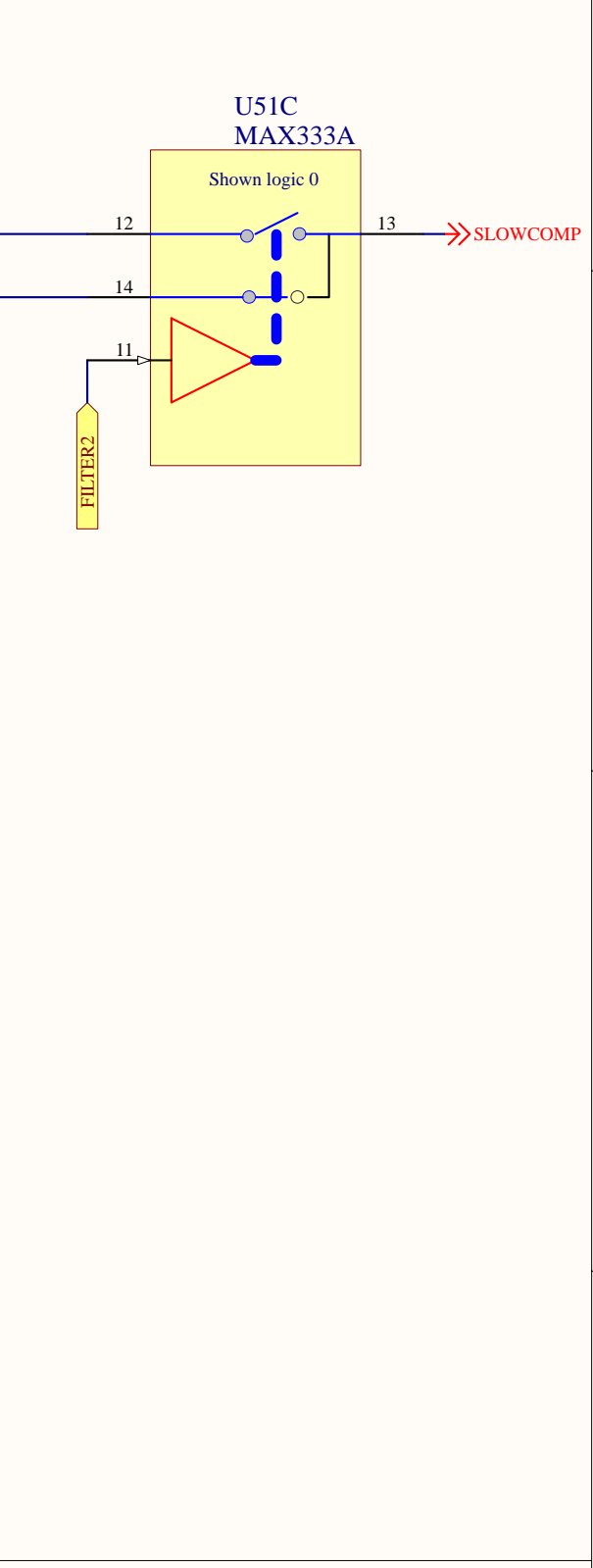
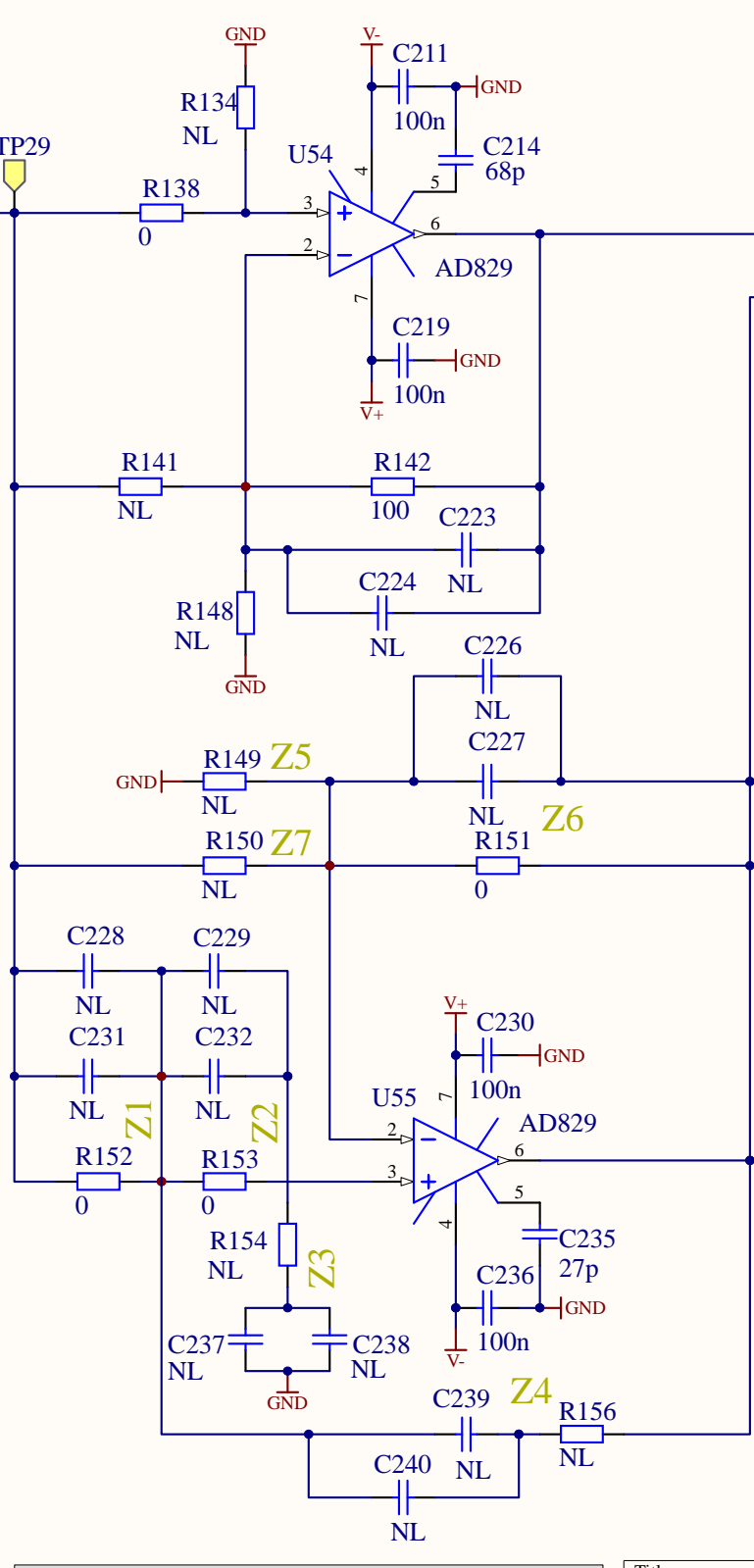
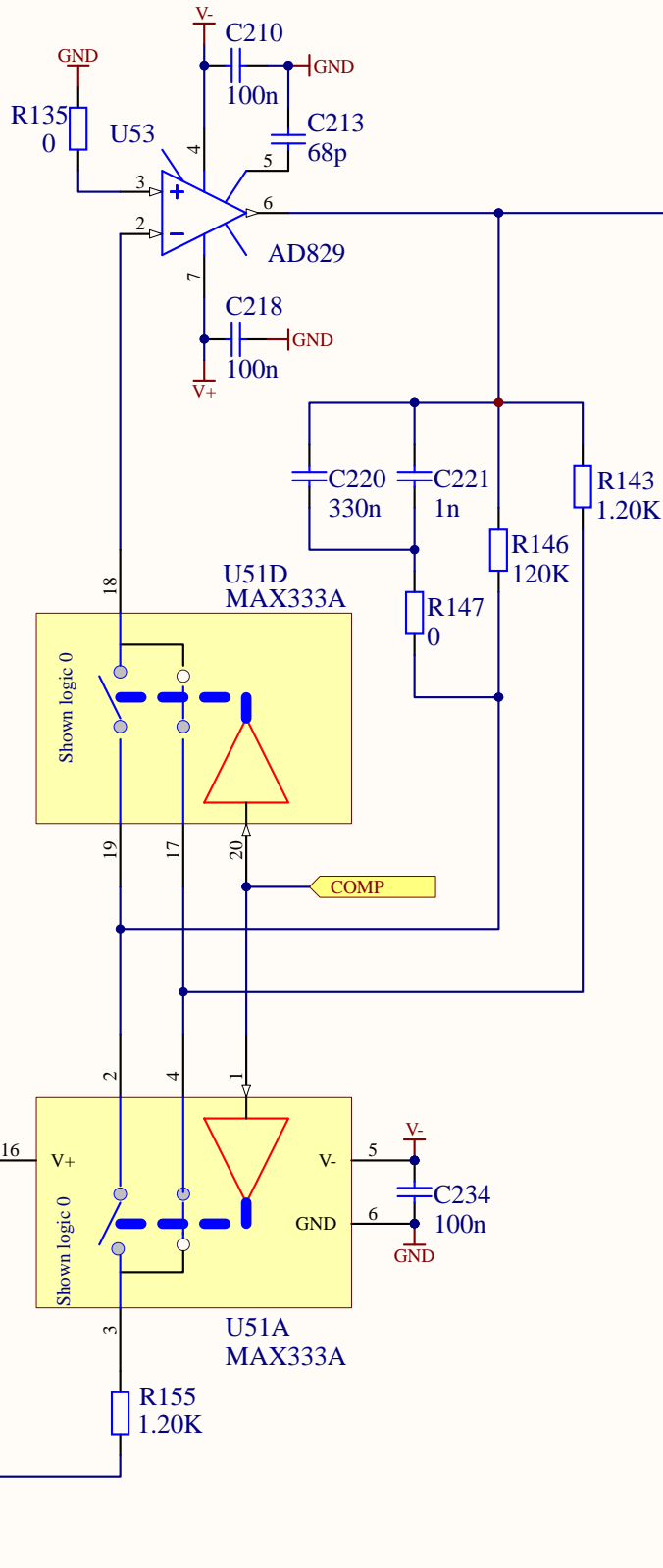
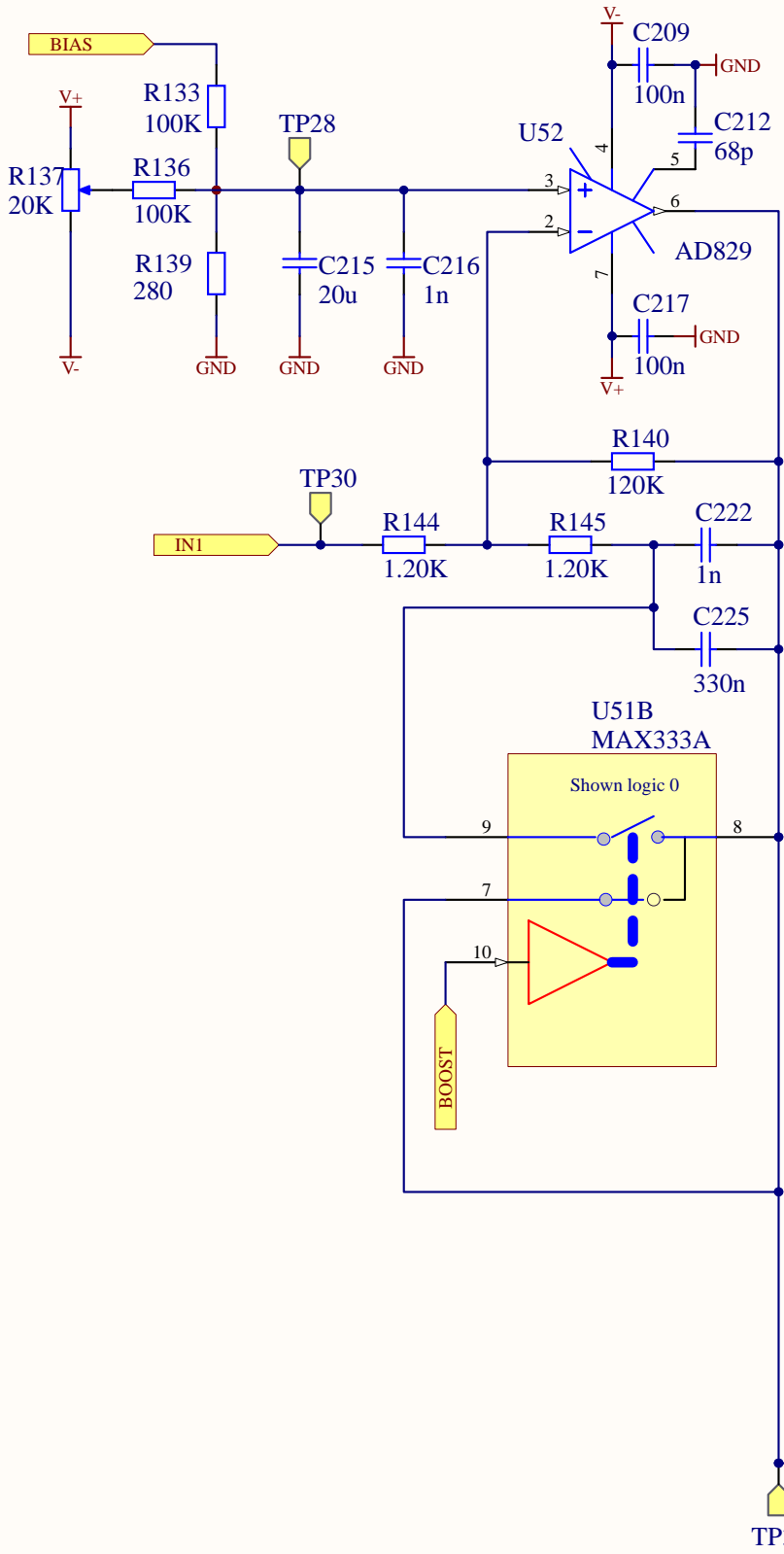

generic filter stage

Title			Common Mode Board: Slow		
Size	Number			Revision	
B	D040180			F	
Date:	3/15/2013	Sheet 11 of 17			
File:	D:\Users\...\CM5B.SchDoc	Drawn By: Daniel Sigg			

generic filter stage
 2 real zeros at 10Hz
 2 real poles at 100Hz
 dc gain of 0.1

ground option path (ALS/LL):
 Z1: 0

100kHz pole

2kHz pole/gain of 5 (MC):
 Z2: 16.5K || (4.7n + 100)
 Z4: 49.9K
 Z5: 10K + 49.9K

500Hz pole/gain of 1 (ALS/LL):
 Z2: 3.32K || (100n + 100)

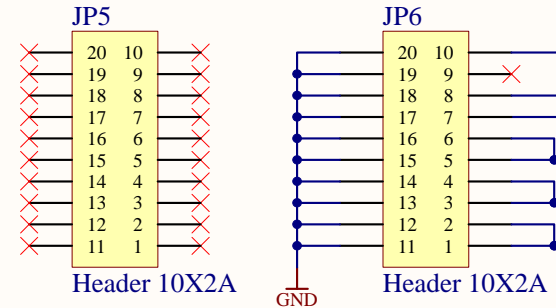
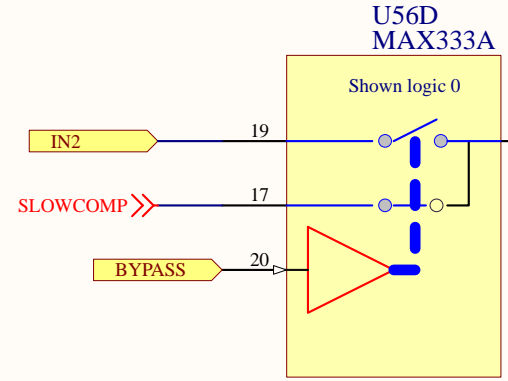

optional daughter board

- M37 M3 standoff, 12mm
- M38 M3 pan, 8mm
- M39 M3 standoff, 12mm
- M40 M3 pan, 8mm
- M41 M3 standoff, 12mm
- M42 M3 pan, 8mm
- M43 M3 standoff, 12mm
- M44 M3 pan, 8mm
- M45 M3 standoff, 12mm
- M46 M3 pan, 8mm
- M47 M3 standoff, 12mm
- M48 M3 pan, 8mm
- Digi-Key 24434K-ND
- M49 M3 pan, 8mm
- M50 M3 pan, 8mm
- M51 M3 pan, 8mm
- M52 M3 pan, 8mm
- M53 M3 pan, 8mm
- M54 M3 pan, 8mm
- McMaster-Carr 90317A115

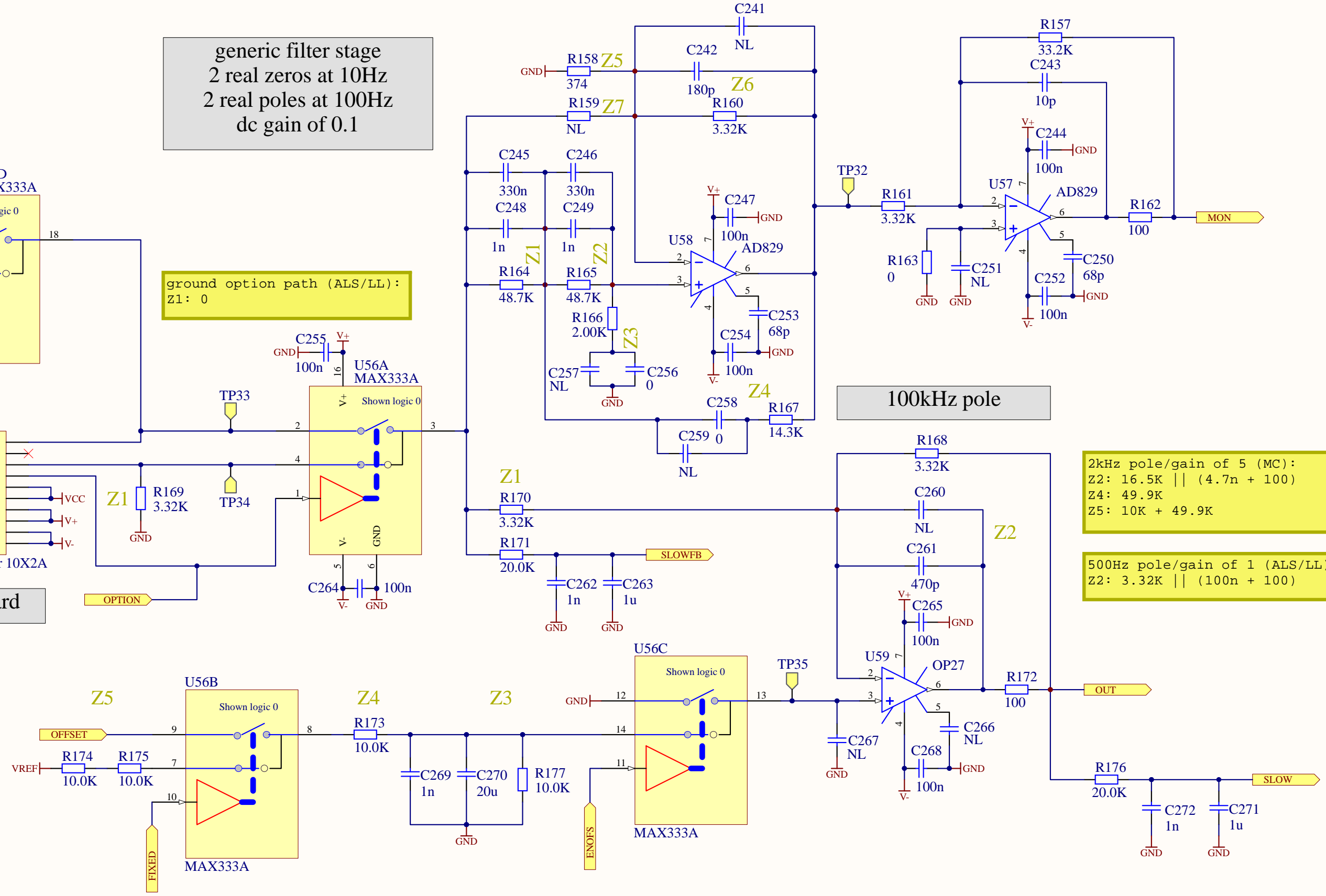

Title		
Common Mode Board: Slow		
Size	Number	Revision
B	D040180	F
Date:	3/15/2013	Sheet12of17
File:	D:\Users\...\CM5C.SchDoc	Drawn By: Daniel Sigg

5Hz high pass

5Hz high pass

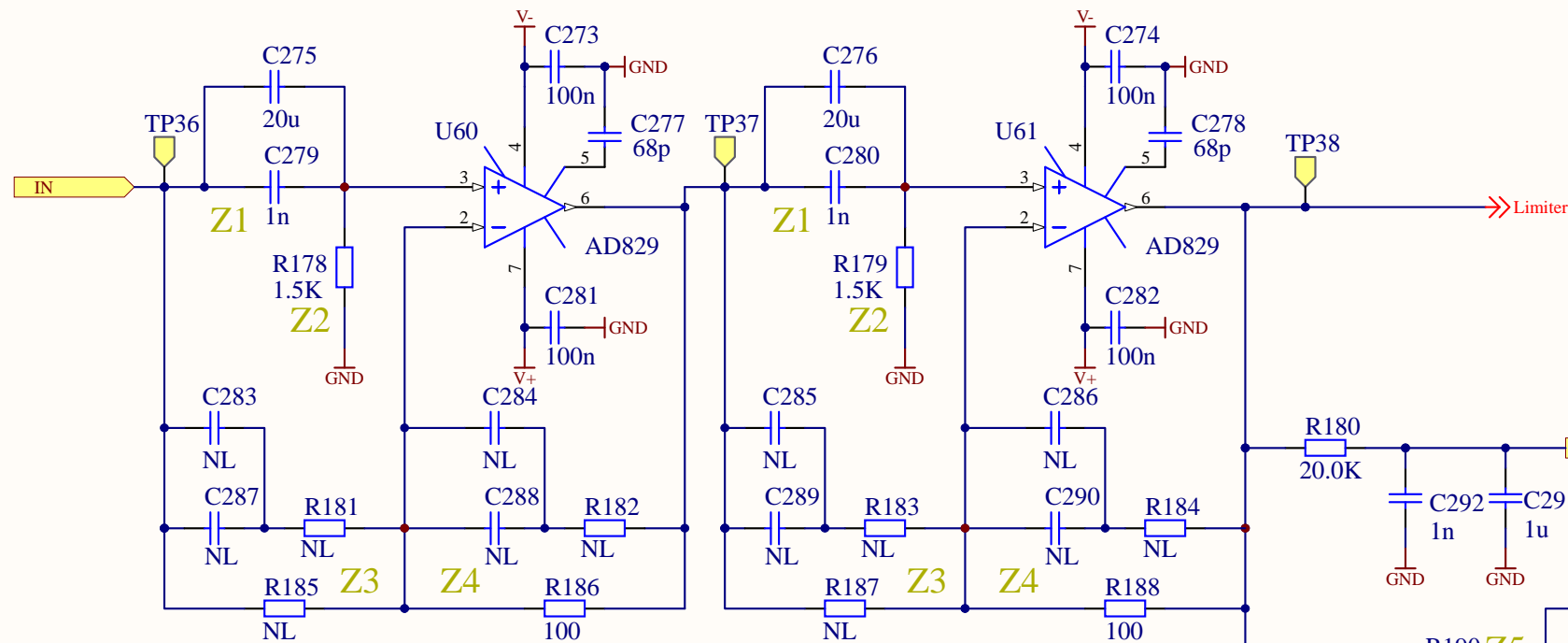

70kHz zero/140kHz pole (MC):
 Z1: NL
 Z2: 0
 Z3(330p + 3.32K) || 3.32K
 Z4: 3.32K || 10p

voltage follower (ALS/LL):
 Z1: 0 Ohm
 Z2: NL
 Z3: NL
 Z4: 100 Ohm

voltage follower (MC):
 Z1: 0 Ohm
 Z2: NL
 Z3: NL
 Z4: 100 Ohm

voltage follower (ALS/LL):
 Z1: 0 Ohm
 Z2: NL
 Z3: NL
 Z4: 100 Ohm

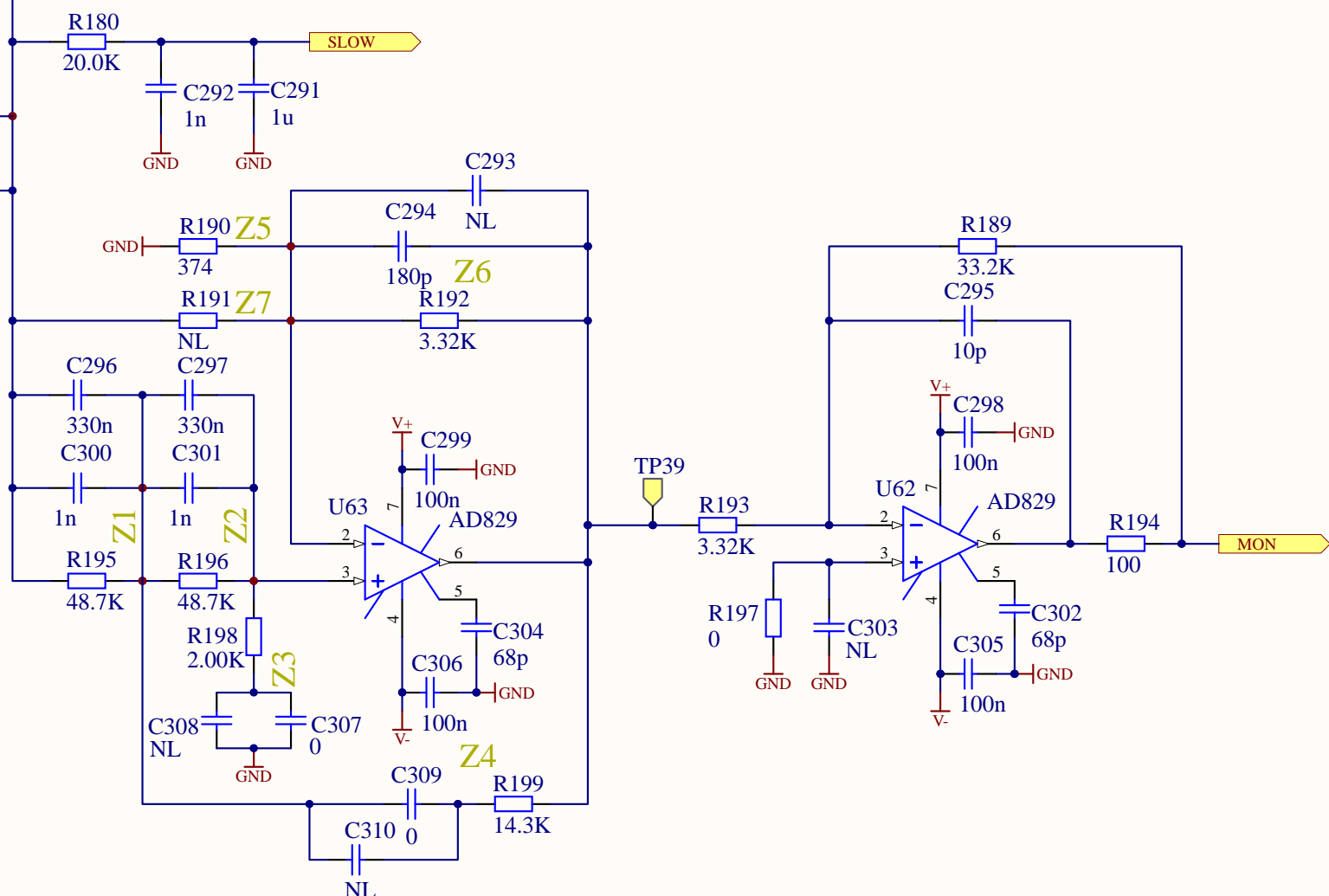

generic filter stage
 2 real zeros at 10Hz
 2 real poles at 100Hz
 dc gain of 0.1

Filter Design Examples:

Butterworth high pass: $G = 1.586$, $Z1 = Z2 = 1/sC$, $Z3 = Z4 = R$
 two zeros at 0Hz, two complex poles at $f = 1/(2 \pi R C)$

Butterworth low pass: $G = 1.586$, $Z1 = Z2 = R$, $Z3 = Z4 = 1/sC$
 two complex poles at $f = 1/(2 \pi R C)$

Whitening: $G = 1$, $Z1 = Z2 = (1/sC) || R2$, $Z3 = Z4 = R1$
 two real zeros at $f = 1/(2 \pi R2 C)$, two real poles at $f = 1/(2 \pi (R1 || R2) C)$

Dewhitening: $G = 1$, $Z1 = Z2 = R1$, $Z3 = Z4 = 1/sC + R2$
 two real poles at $f = 1/(2 \pi (R1 + R2) C)$, two real zeros at $f = 1/(2 \pi R2 C)$

Title		
Common Mode Board: Fast Path		
Size	Number	Revision
B	D040180	F
Date:	3/15/2013	Sheet13of17
File:	D:\Users\...\CM6A.SchDoc	Drawn By: Daniel Sigg

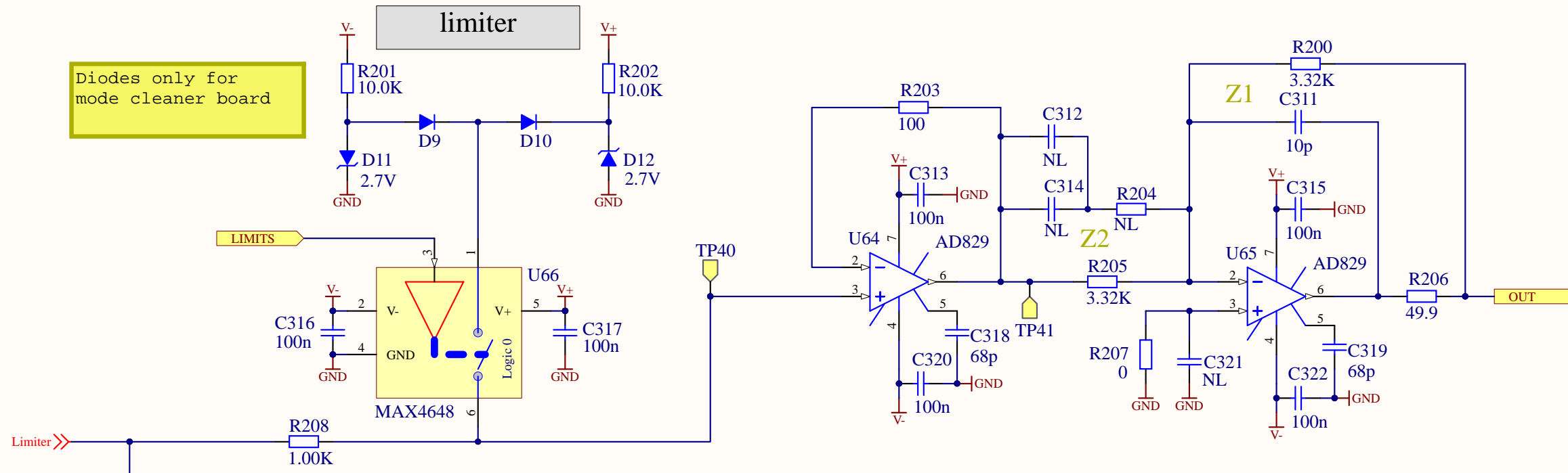

Diodes only for mode cleaner board

window comparator & one-shot

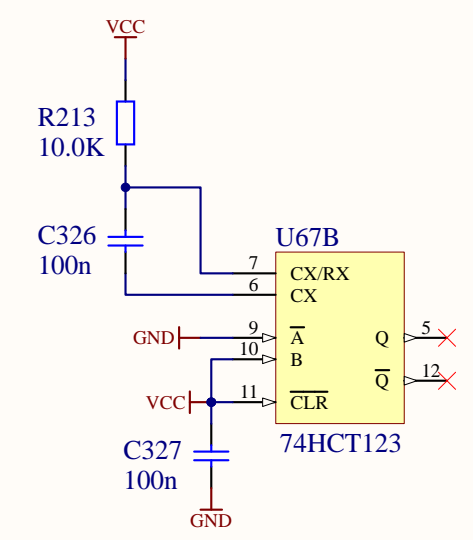
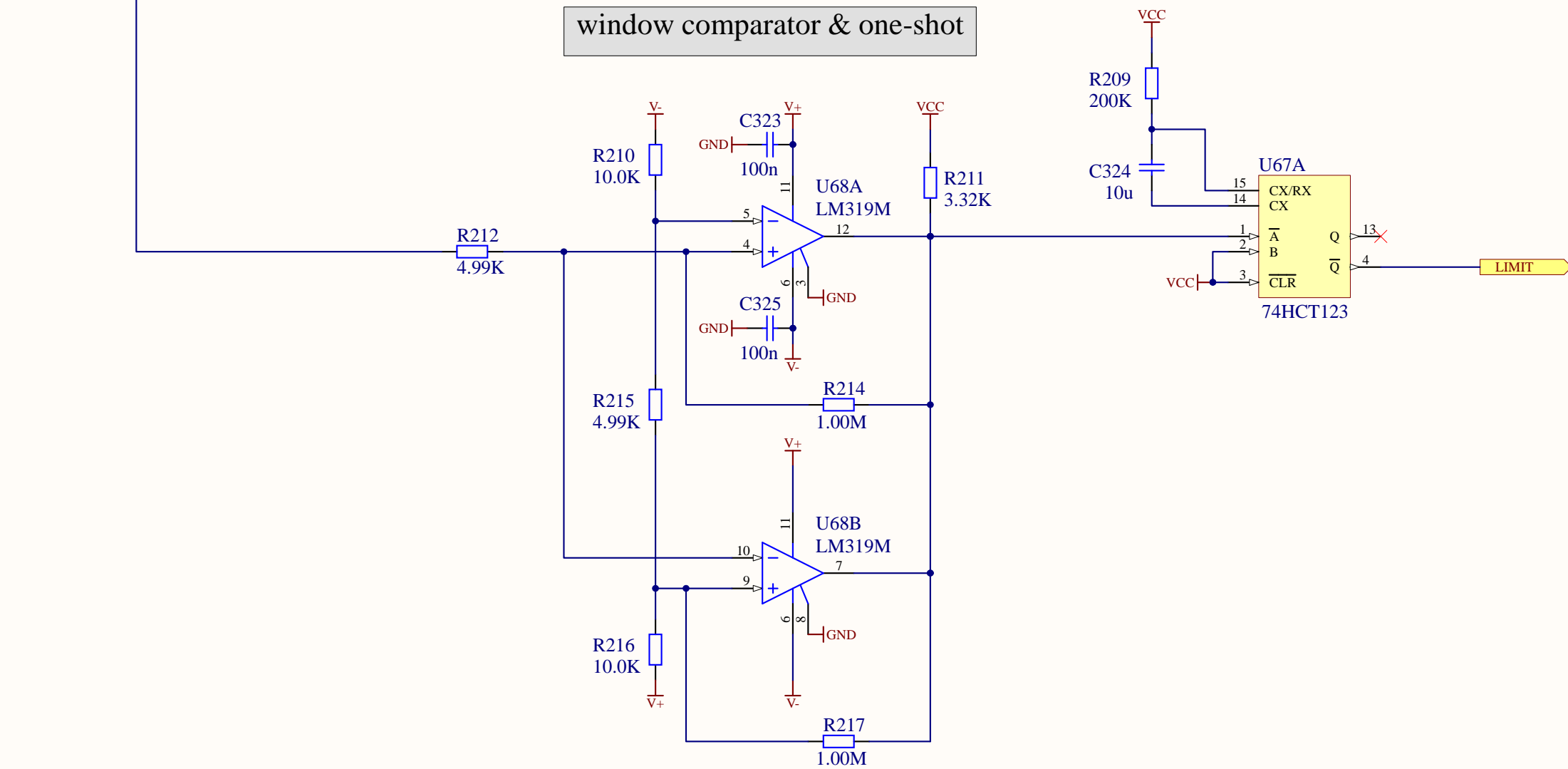

Title		
Common Mode Board: Output Limiter		
Size	Number	Revision
B	D040180	F
Date:	3/15/2013	Sheet14of17
File:	D:\Users\...\CM6B.SchDoc	Drawn By: Daniel Sigg

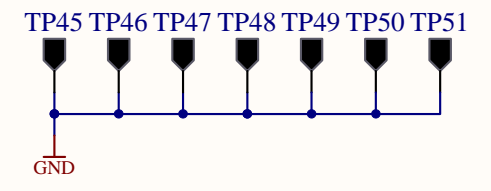
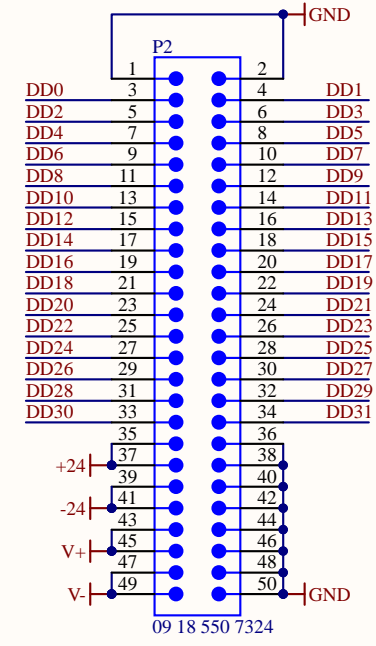
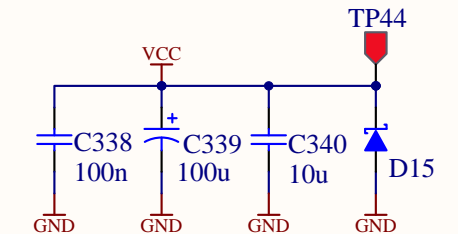
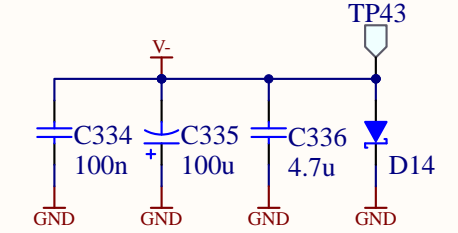
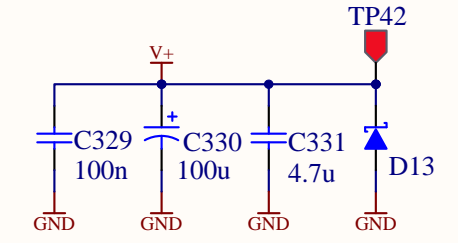
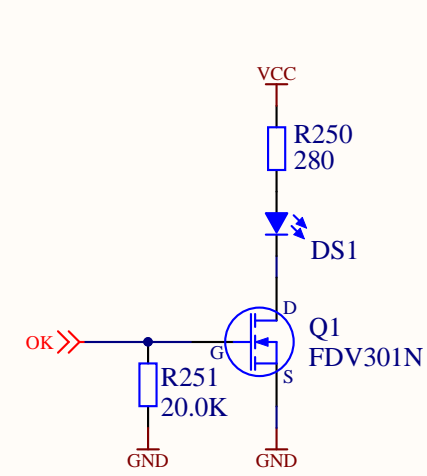
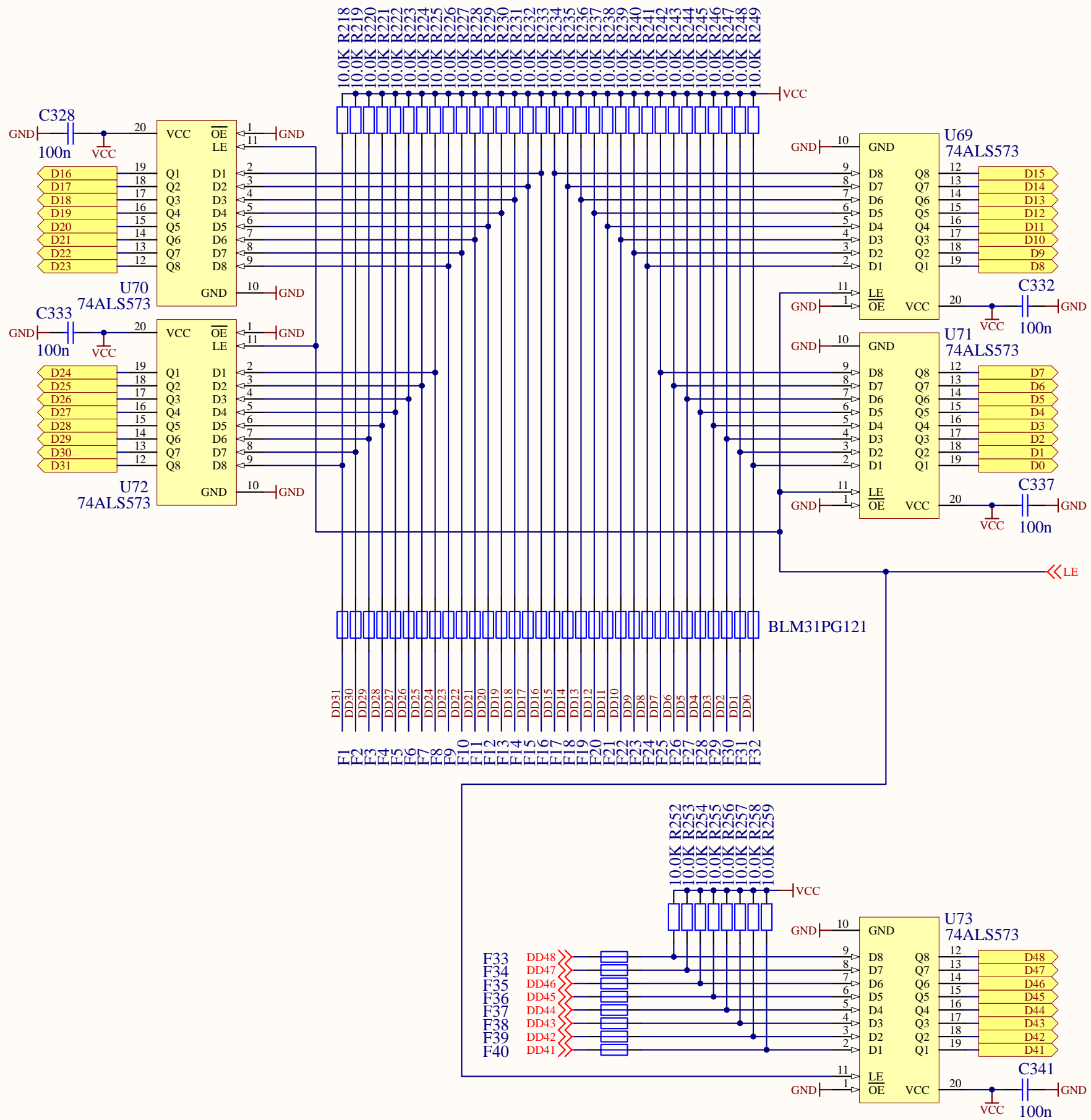

Title Common Mode Board: Backplane(P1)		
Size B	Number D040180	Revision F
Date: 3/15/2013	Sheet15of17	
File: D:\Users\...\CM7A.SchDoc	Drawn By: Daniel Sigg	

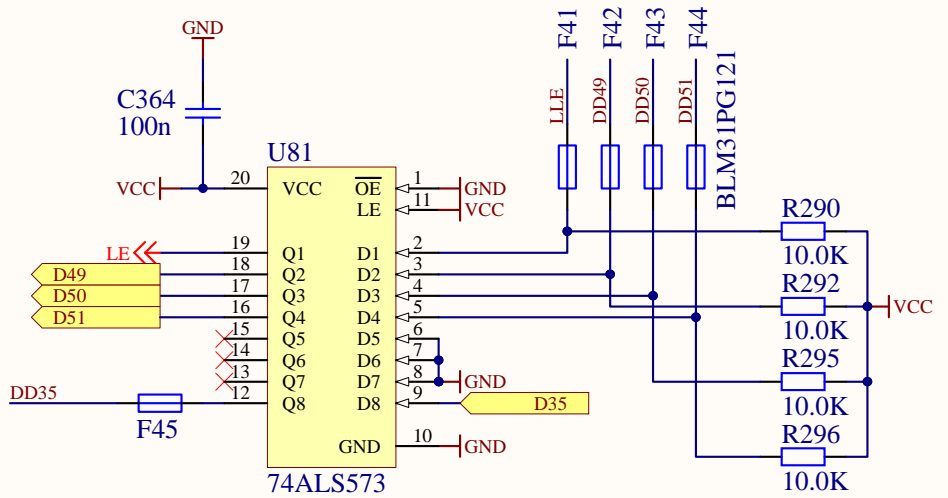
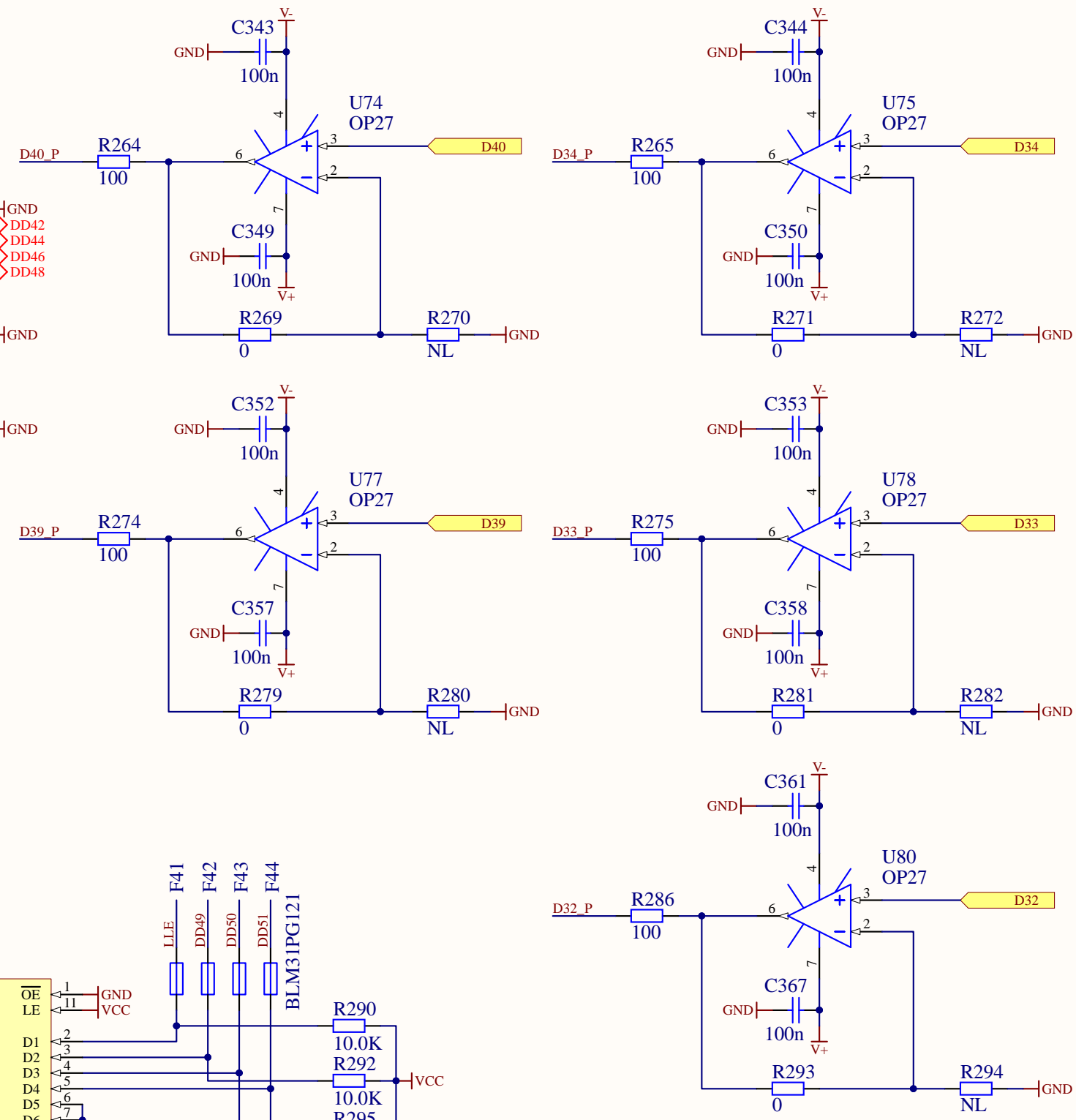
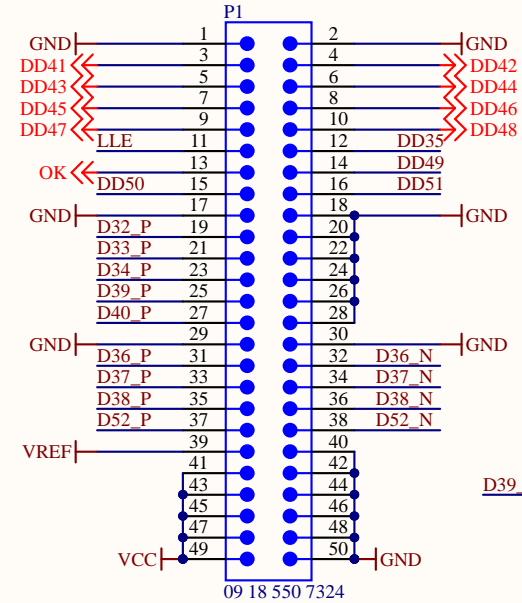
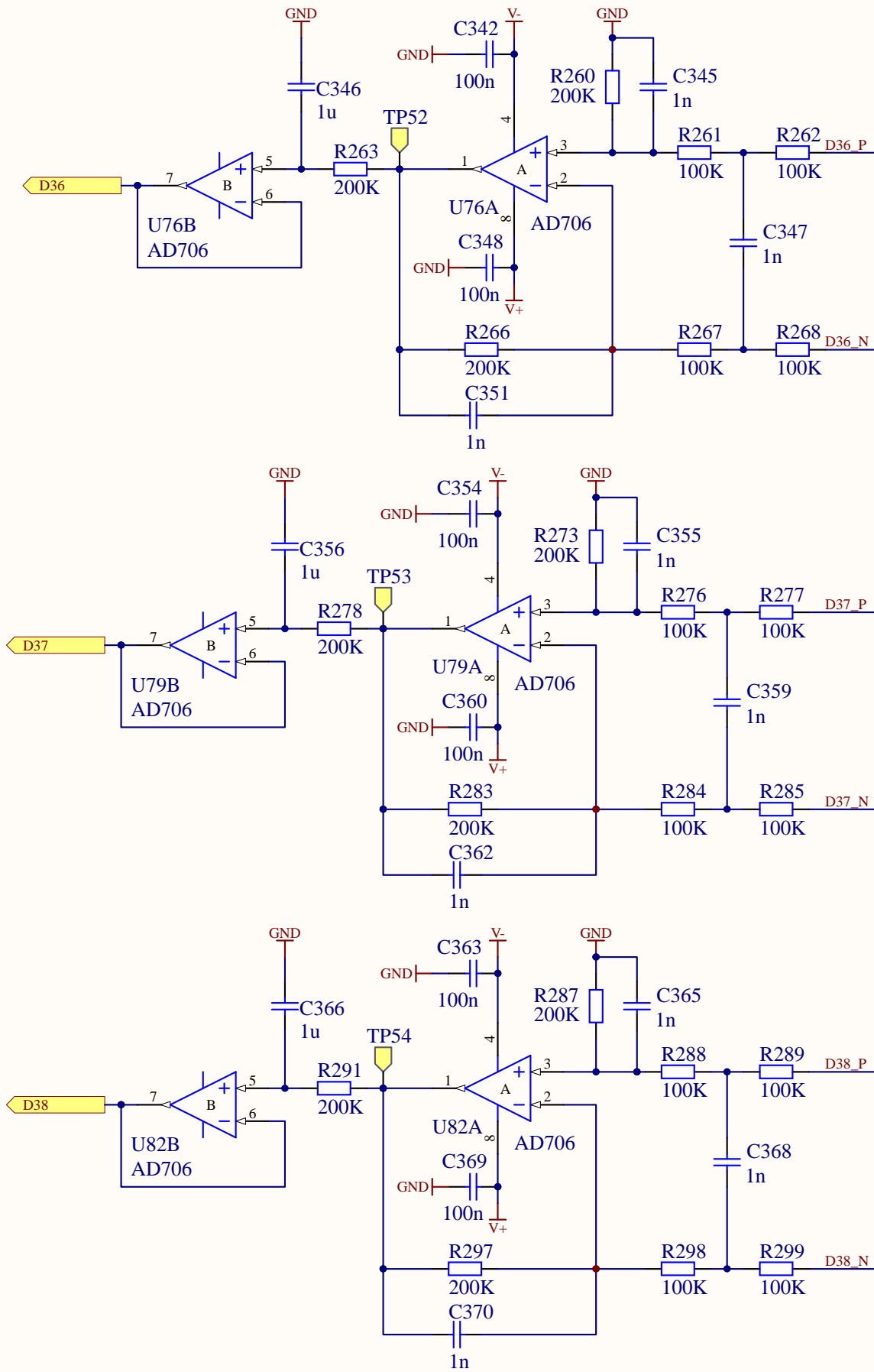

Title		
Common Mode Board: Backplane(P2)		
Size	Number	Revision
B	D040180	F
Date:	3/15/2013	Sheet16of17
File:	D:\Users\...\CM7B.SchDoc	Drawn By: Daniel Sigg

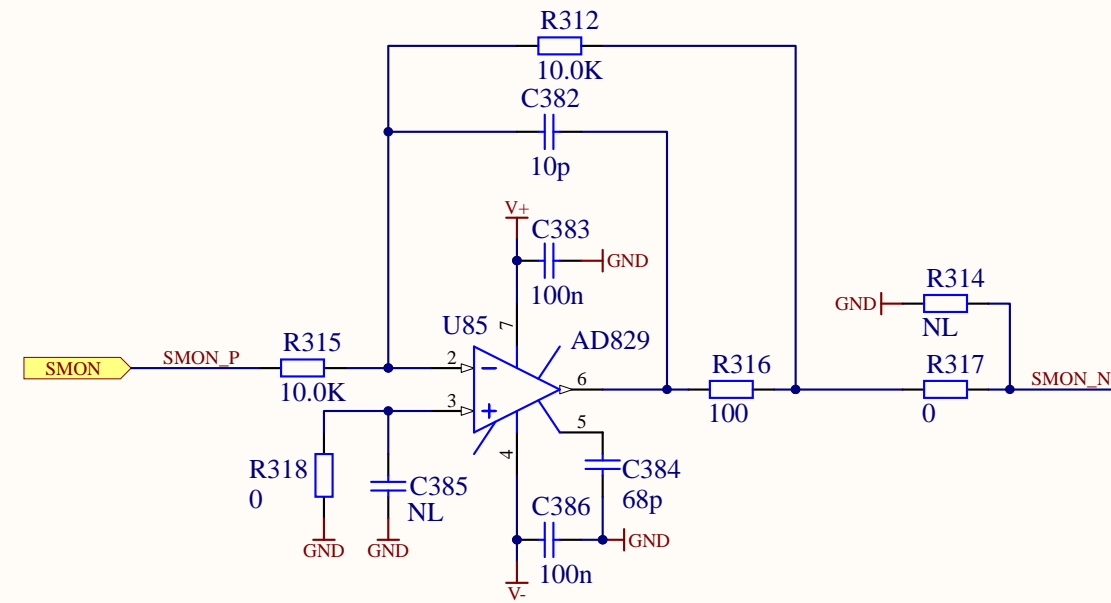
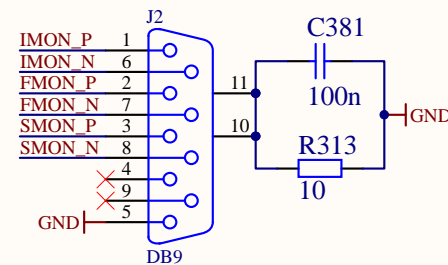
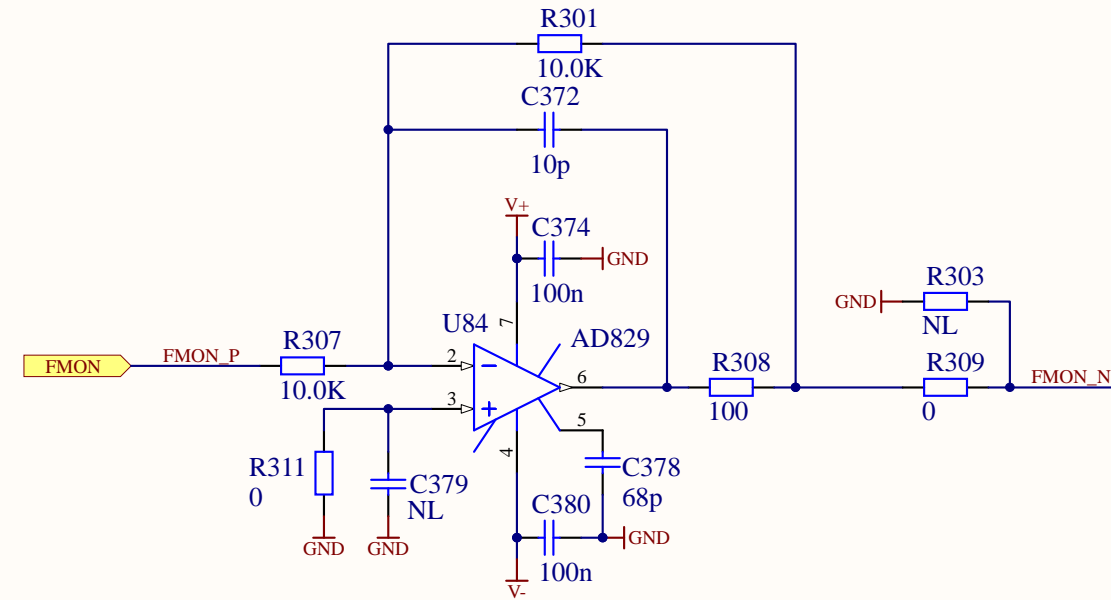
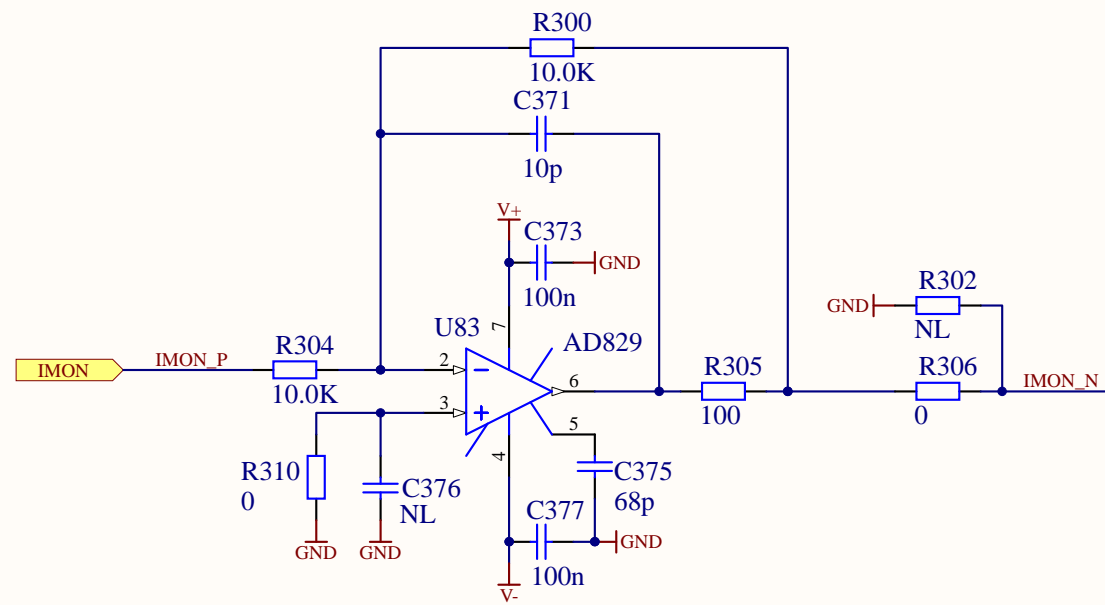

Title			Common Mode Board: DAQ
Size	Number	Revision	
B	D040180	F	
Date:	3/15/2013	Sheet 17 of 17	
File:	D:\Users\...\CM8.SchDoc	Drawn By: Daniel Sigg	