

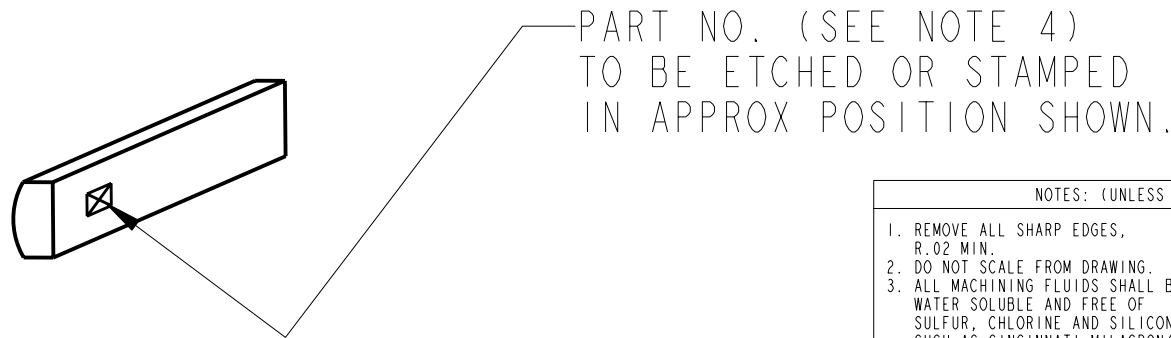

REV.	DATE	DCN #	DRAWING TREE #
A	30-OCT-06	E060260-00	.

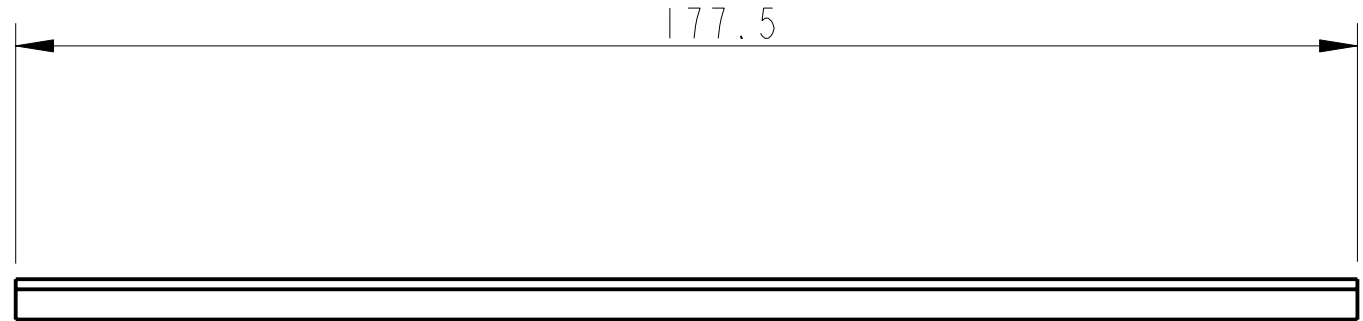
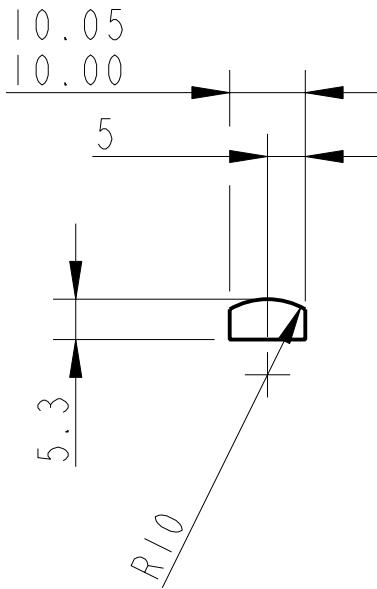

NOTES: (UNLESS OTHERWISE SPECIFIED)		CALIFORNIA INSTITUTE OF TECHNOLOGY MASSACHUSETTS INSTITUTE OF TECHNOLOGY IGR, GLASGOW UNIVERSITY GEO 600 GROUP RUTHERFORD APPLETON LABORATORIES												
1. REMOVE ALL SHARP EDGES, R.02 MIN. 2. DO NOT SCALE FROM DRAWING. 3. ALL MACHINING FLUIDS SHALL BE WATER SOLUBLE AND FREE OF SULFUR, CHLORINE AND SILICONE, SUCH AS CINCINNATI MILACRON'S CIMTECH 410 (STAINLESS STEEL) 4. SCRIBE, ENGRAVE OR STAMP DRAWING PARTNUMBER ON NOTED SURFACE OF PART AND A THREE DIGIT SERIAL NUMBER. SERIAL NUMBERS START AT 001 FOR THE FIRST PART AND PROCEED CONSECUTIVELY. USE .07" HIGH CHARACTERS. EXAMPLE: D020188- 001. A VIBRATORY TOOL MAY BE USED.	DIMENSIONS ARE IN mm [INCHES] TOLERANCES: X.XX ±0.2 mm ° ANGULAR ±0.25 °													
	MATERIAL: PFA 440 HP		SYSTEM ADVANCED LIGO											
	FINISH: CLEAN √μm [μin] Ra = 1.6		SUB-SYSTEM SUS											
	<table border="1"> <thead> <tr> <th></th> <th>NAME</th> <th>DATE</th> </tr> </thead> <tbody> <tr> <td>DRAWN</td> <td>NJS/FEL</td> <td>01/AUG/06</td> </tr> <tr> <td>CHECKED</td> <td>J'OD</td> <td>--/--/--</td> </tr> <tr> <td>APPROVED</td> <td>IW</td> <td>--/--/--</td> </tr> </tbody> </table>			NAME	DATE	DRAWN	NJS/FEL	01/AUG/06	CHECKED	J'OD	--/--/--	APPROVED	IW	--/--/--
	NAME	DATE												
DRAWN	NJS/FEL	01/AUG/06												
CHECKED	J'OD	--/--/--												
APPROVED	IW	--/--/--												
SIZE A DRG. NO. D060449		SCALE 1:1 PROJECTION:  SHEET 1 OF 1												