

REV.	DATE	DCN #	DRAWING TREE #

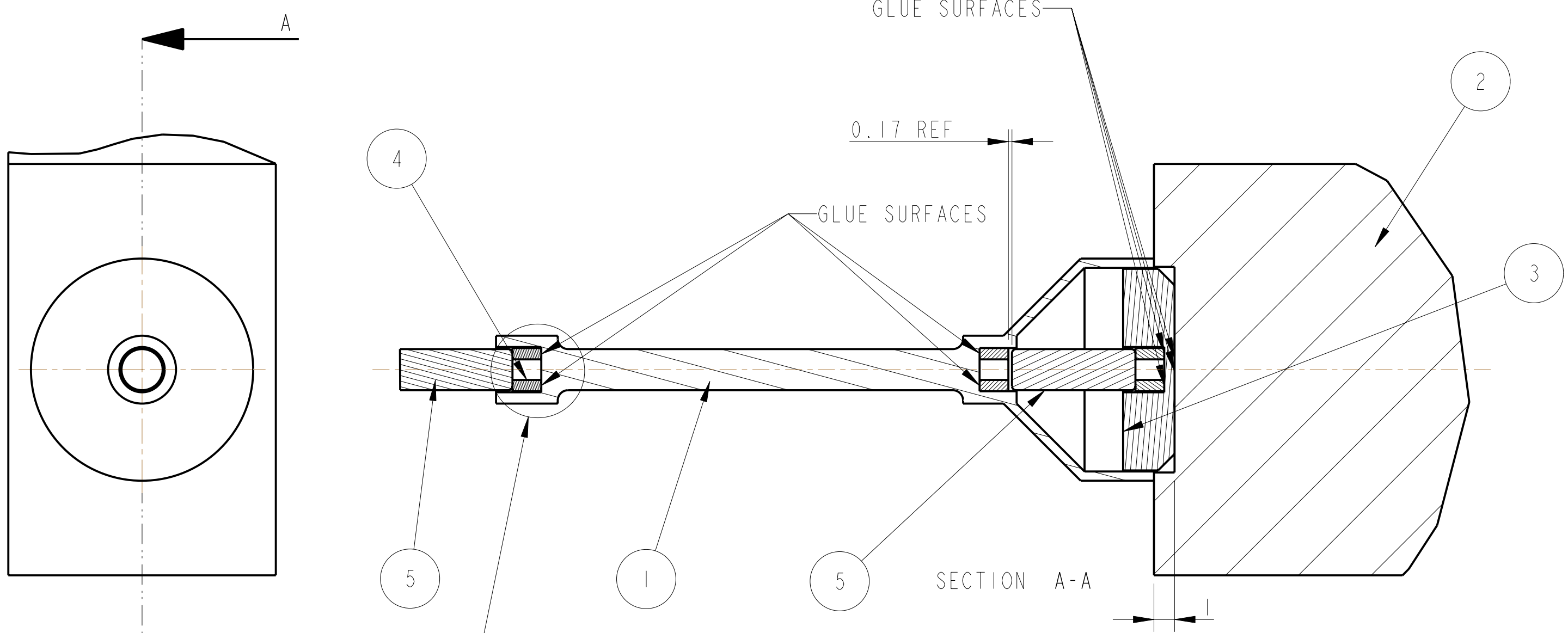

SEE DETAIL A

GLUE FILLET
ENSURE GLUE DOES NOT
PUSH STEEL DISC FORWARD

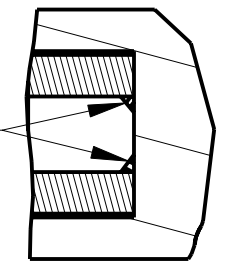

DETAIL A
SCALE 10:1

NOTE:
PART 2 (D070236) WILL
BE REPLACED BY
A GLASS MASS IN
SOME INSTANCES

ITEM	QTY	SPARE	TOTAL	PART NUMBER	DESCRIPTION	MATERIALS
1	4			D070235	MAGNET HOLDER; (EXTERNAL SHIELDED MAGNETS)	AL ALLOY: 5083 OR SIMILAR
2	1			D070236	PENULTIMATE MASS FLAG MOUNT; (EXTERNAL SHIELDED MAGNETS)	AL ALLOY: 5083
3	4			D070237	MAGNET BASE; (EXTERNAL SHIELDED MAGNETS)	AL/ALLOY: 5083 OR SIMILAR
4	12			D070238	STEEL DISK; (EXTERNAL SHIELDED MAGNETS)	ST. STEEL: 416 - MAGNETIC
5	8			D0901345	2MM DIA X 6MM MAGNET; .	AS PER SPEC: -----
PARTS LIST						

NOTES: (UNLESS OTHERWISE SPECIFIED)

- REMOVE ALL SHARP EDGES, R.02 MIN.
- DO NOT SCALE FROM DRAWING.
- ALL MACHINING FLUIDS SHALL BE WATER SOLUBLE AND FREE OF SULFUR, CHLORINE AND SILICONE, SUCH AS CINCINNATI MILACRON'S CIMTECH 410 (STAINLESS STEEL)
- SCRIBE, ENGRAVE OR STAMP DRAWING PART NUMBER ON NOTED SURFACE OF PART AND A THREE DIGIT SERIAL NUMBER. SERIAL NUMBERS START AT 001 FOR THE FIRST PART AND PROCEED CONSECUTIVELY. USE .07" HIGH CHARACTERS. EXAMPLE: D020188- 001. A VIBRATORY TOOL MAY BE USED.

DIMENSIONS ARE IN mm [INCHES]
TOLERANCES:
X.XX ± mm
ANGULAR ± °

MATERIAL: AS DRW

FINISH:
√μm [μin] Ra = -----

DRAWN	J O'DELL	10/JUN/07
CHECKED	MB	15/MAR/10
APPROVED	JOD	15/MAR/10

MIT CALIFORNIA INSTITUTE OF TECHNOLOGY
MASSACHUSETTS INSTITUTE OF TECHNOLOGY
1GR, GLASGOW UNIVERSITY GEO 600 GROUP
RUTHERFORD APPLETON LABORATORIES

SYSTEM **aLIGO**

SUB-SYSTEM **SUS**

NEXT ASSY **PENULTIMATE MASS**

PART NAME **PEN RE MASS MAGNETS
(EXTERNAL SHIELDED MAGNETS)**

SCALE 5:1 PROJECTION: SHEET 1 OF 1

DRG. NO. **D070234**

SIZE **B**

REV **C.**