

REV.	DATE	DCN #	DRAWING TREE #
B	21/DEC/07	E060260-B	

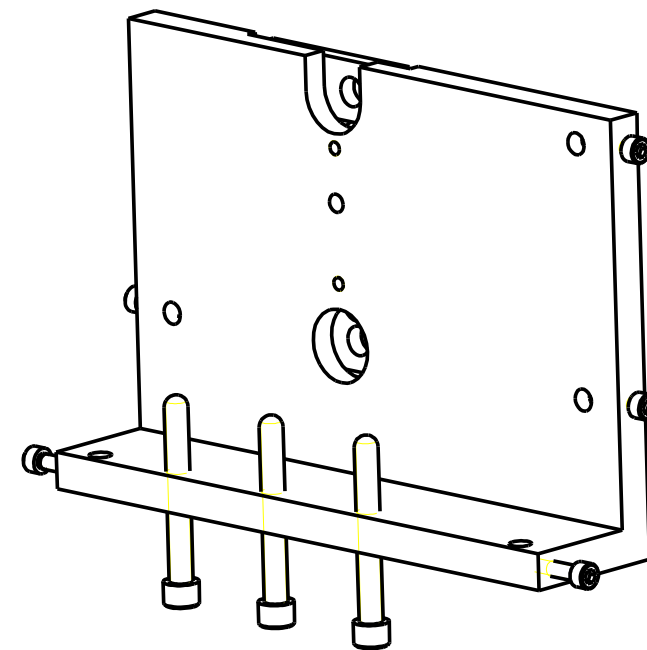
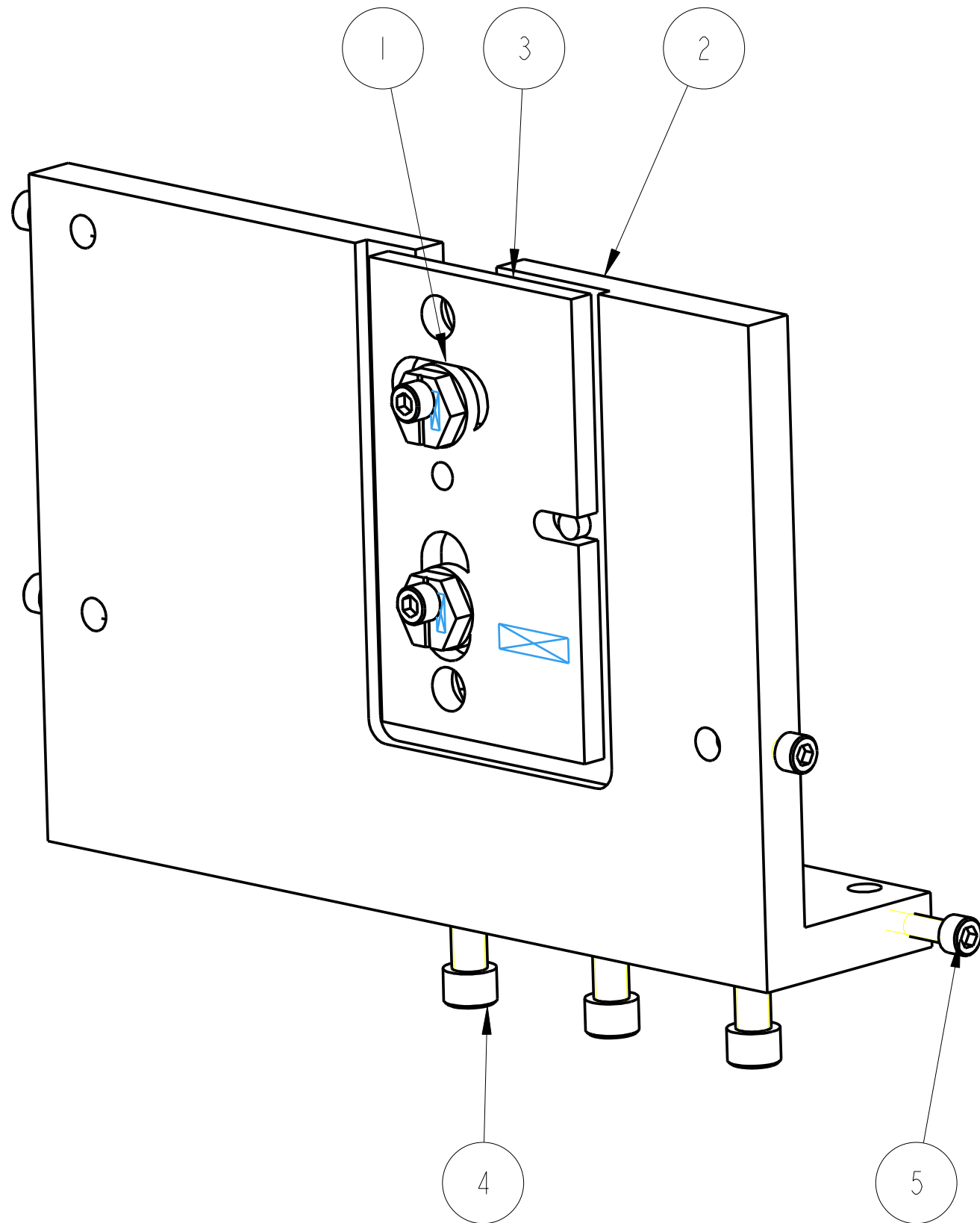

SCALE 1:2

ITEM	QTY	SPARE	TOTAL	PART NUMBER	DESCRIPTION	MATERIALS
1	2			D060336	2MM CAM; OSEM ADJUSTER	PH BRONZE: -----
2	1			D070544	TEST CHAIN UIM STOP; RIGHT HAND	AL ALLOY: 6061
3	1			D070548	UIM MASS STOP; BOTH CHAINS	AL ALLOY: 5083
4	3				1/4" 20 UNC X 2" CAP HEAD, SPHERICAL TIP	ST. STEEL 316
5	7				8-32 UNC X 0.625" CAP HEAD; .	ST STEEL 316

PARTS LIST

NOTES: (UNLESS OTHERWISE SPECIFIED)

- REMOVE ALL SHARP EDGES, R.02 MIN.
- DO NOT SCALE FROM DRAWING.
- ALL MACHINING FLUIDS SHALL BE WATER SOLUBLE AND FREE OF SULFUR, CHLORINE AND SILICONE, SUCH AS CINCINNATI MILACRON'S CIMTECH 410 (STAINLESS STEEL)
- SCRIBE, ENGRAVE OR STAMP DRAWING PART NUMBER ON NOTED SURFACE OF PART AND A THREE DIGIT SERIAL NUMBER. SERIAL NUMBERS START AT 001 FOR THE FIRST PART AND PROCEED CONSECUTIVELY. USE .07" HIGH CHARACTERS. EXAMPLE: D020188- 001. A VIBRATORY TOOL MAY BE USED.

DIMENSIONS ARE IN mm [INCHES]		CALIFORNIA INSTITUTE OF TECHNOLOGY MASSACHUSETTS INSTITUTE OF TECHNOLOGY 1GR, GLASGOW UNIVERSITY GEO 600 GROUP RUTHERFORD APPLETON LABORATORIES
TOLERANCES:		
X.XX ±N/A mm		SYSTEM ADVANCED LIGO
ANGULAR ±N/A °		SUB-SYSTEM SUS
MATERIAL: AS DRW		NEXT ASSY D060454
AS DRW		PART NAME UIM TC EQUAKE STOP ASSY #2
FINISH: AS DRW		
√μm [μin] Ra = AS DRW		
	NAME	DATE
DRAWN	I WILMUT	05/Dec/07
CHECKED	J'OD	10/DEC/07
APPROVED	IW	10/DEC/07

STZE B	DRG. NO. D070543	REV B
SCALE 1:1	PROJECTION:	SHEET 1 OF 1