

Ass5-Flexure
 LVDT readout
 DC actuation (magnet on frame);
 use CW 40.3
 c.o.w. position = -0.02 mm
 mass = 2.851 Kg
 Moments of inertia:
 I1= 1087,446 Kgmm²
 I2= 33380,136 Kgmm²
 I3= 33563,470 Kgmm²

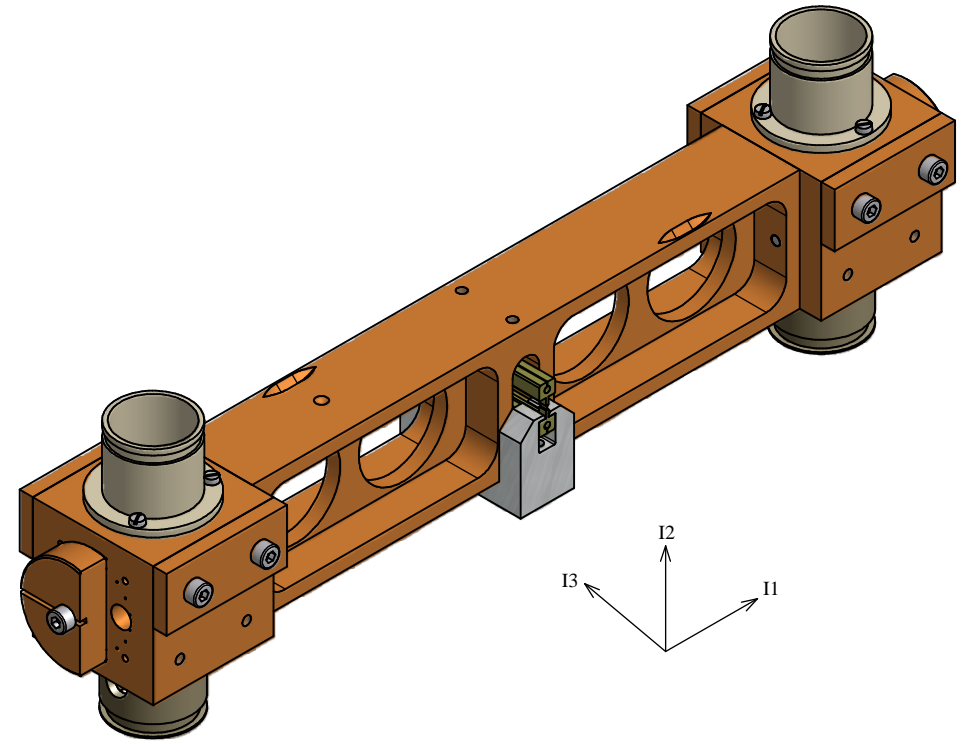

Ass6-Flexure
 LVDT readout
 AC actuation (coil on frame);
 use CW 40.4
 c.o.w. position = -0.02 mm
 mass = 2.873 Kg
 Moments of inertia:
 I1= 1108,073 Kgmm²
 I2= 33748,771 Kgmm²
 I3= 33927,131 Kgmm²

| | | |
|--|---------------------------------------|----------|
| | | |
| | | |
| | | |
| | added moments of inertia | 13-07-09 |
| ref. | note | date |
| modifications | | |
| | DESIGNED FOR R. De Salvo | |
| | DRAWN BY G. Gennaro-PROMECC | |
| TITLE TILTMETER ASSEMBLY LVDT READOUT | DATE 14-06-08 | |
| | LIGO-D081021-01-D | |
| | SCALE 1/1 | A2 |