

8 7 6 5 4 3 2 1

NOTES:
 ① HELICOILS TO BE INSTALLED INTO ITEM NO. 1 BY LIGO PRIOR TO ASSEMBLY AND AFTER ALL PARTS ARE CLEANED AND BAKED.
 ② RIGHT HAND CONFIGURATION IDENTICAL EXCEPT ITEM NO. 1 IS REVERSED IN ORDER TO KEEP EQ STOP AWAY FROM CHAMFERED EDGE OF MASS.

| REV. | DATE | DCN # | DRAWING TREE # |
|------|-------------|----------|----------------|
| v1 | 11 OCT 2010 | - | E0900353 |
| v2 | 13 MAY 2010 | E0900505 | E0900353 |
| - | - | - | - |

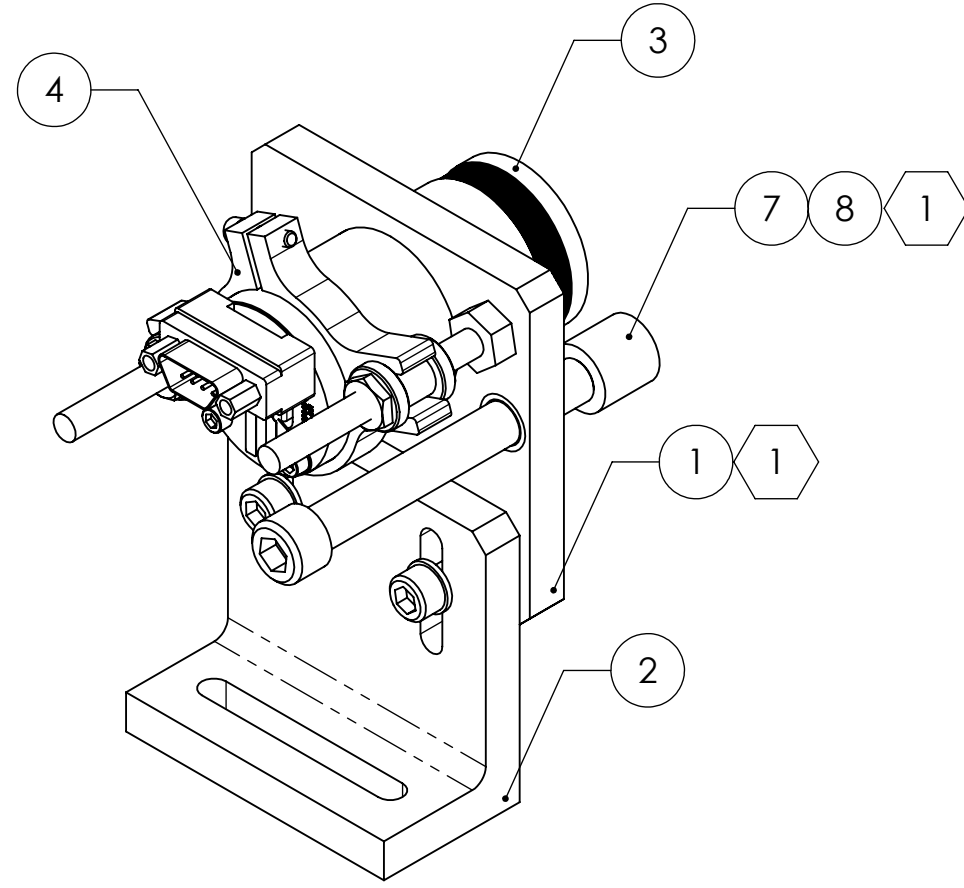

② LEFT HAND CONFIGURATION

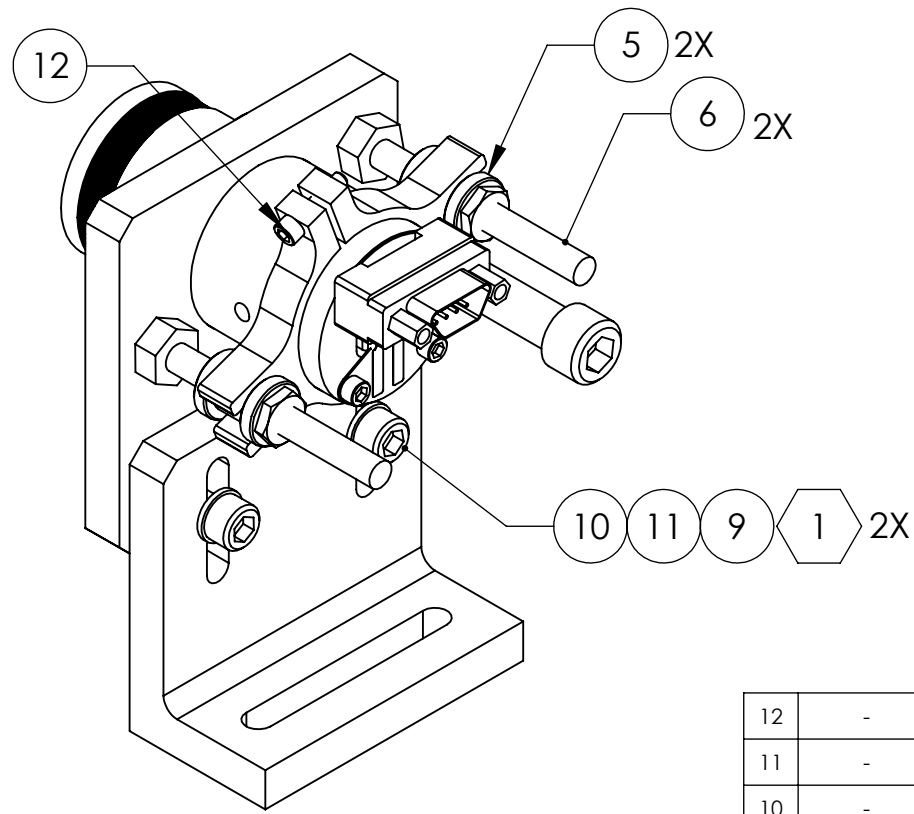

REVERSE ISOMETRIC VIEW

| ITEM NO. | PART NUMBER | DESCRIPTION | MATERIAL | REQ | SPARE | TOTAL |
|----------|-------------|---|----------------------|-----|-------|-------|
| 12 | - | SCREW, SOCKET HEAD CAP, #2-56 UNC-2A X 0.375 LONG | 300 SSSL | 1 | 1 | 2 |
| 11 | - | WASHER, FLAT, #8 (NAS 620-C8 OR EQUIVALENT) | 300 SSSL | 2 | - | 2 |
| 10 | - | SCREW, SOCKET HEAD CAP, #8-32 UNC-2A X 0.625 LONG | 300 SSSL | 2 | - | 2 |
| 9 | 1185-2EN246 | HELICOIL, #8-32 X 0.246 LONG | NITRONIC 60 | 2 | 1 | 3 |
| 8 | 1185-4EN250 | HELICOIL, 1/4-20 X 0.25 LONG | NITRONIC 60 | 1 | 1 | 2 |
| 7 | D0900932 | EARTHQUAKE STOP FOR GLASS (GLASS TIP), SIMPLIFIED, 2 INCH | N/A | 1 | - | 1 |
| 6 | D1000659 | ADJUSTER SHAFT | 304, 316 OR 302 SSSL | 2 | 1 | 3 |
| 5 | D1000660 | ADJUSTMENT NUT | PEEK | 2 | 1 | 3 |
| 4 | D0901548 | AOSEM ADJUSTMENT COLLAR | 6061-T6 Al | 1 | - | 1 |
| 3 | D0901065 | AOSEM ASSEMBLY | - | 1 | - | 1 |
| 2 | D0902415 | AOSEM ALIGNMENT BRACKET MOUNT | 6061-T6 Al | 1 | - | 1 |
| 1 | D0902417 | AOSEM ALIGNMENT BRACKET | 6061-T6 Al | 1 | - | 1 |

| PARTS LIST | | | | | | |
|---|--------------------------|---|-------------|-------------------|-----------------------------|---------------------|
| CALIFORNIA INSTITUTE OF TECHNOLOGY MASSACHUSETTS INSTITUTE OF TECHNOLOGY | | PART NAME LOWER AOSEM ALIGNMENT ASSY, TEST MASS | | | | |
| SYSTEM ADVANCED LIGO | SUB-SYSTEM SUS | DESIGNER W. RASCH | 07 OCT 2009 | SIZE | DWG. NO. D0902208 | REV. v2 |
| DRAFTER B. MOORE | 22 APR 2010 | CHECKER M. MEYER | 23 APR 2010 | SCALE: 1:1 | PROJECTION: | SHEET 1 OF 1 |
| NEXT ASSY D020700 | | | | | | |

D0902208_AdvLIGO_SUS_HSTS_Lower AOSEM Alignment Ass'y, Test Mass, PART PDM REV: X-027, DRAWING PDM REV: X-018

8 7 6 5 4 3 2 1