

(Ø 468)

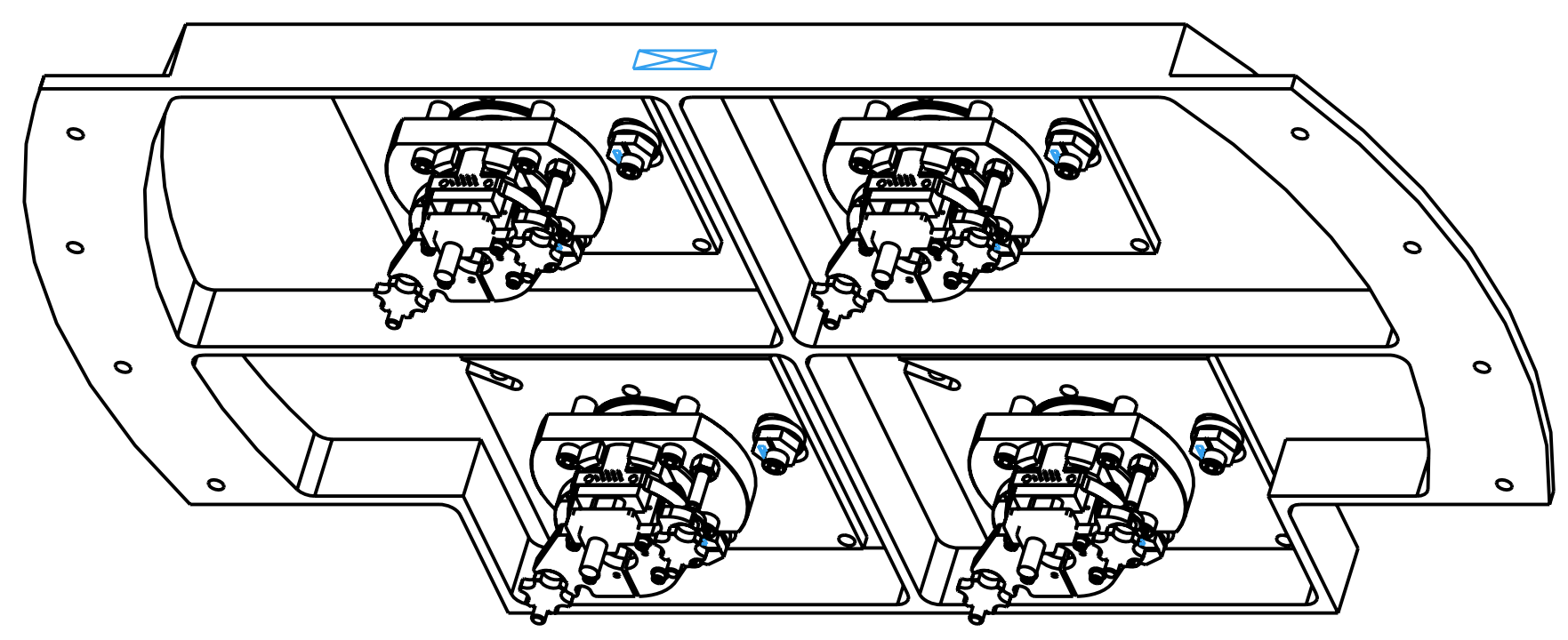

SCALE 1:2

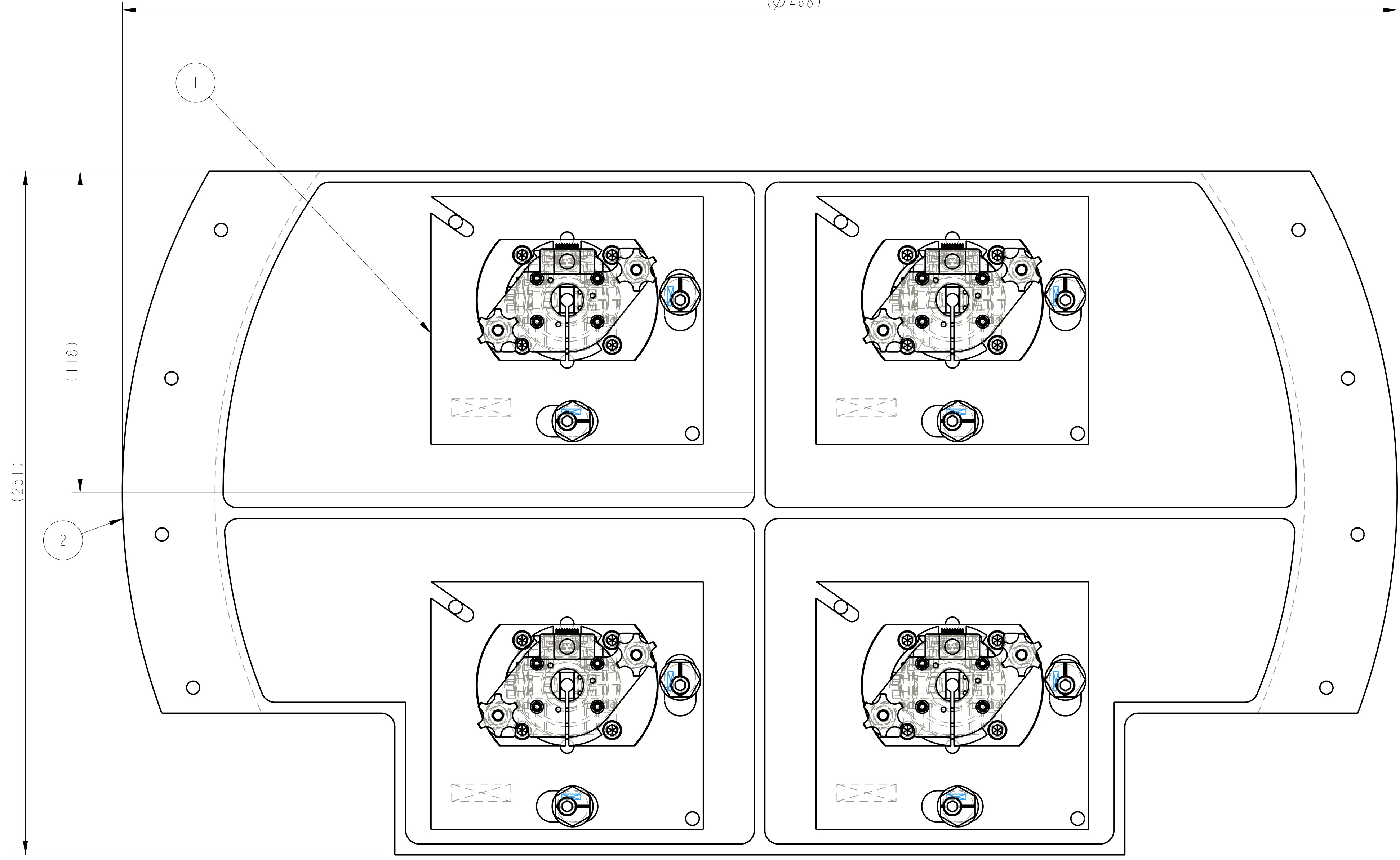
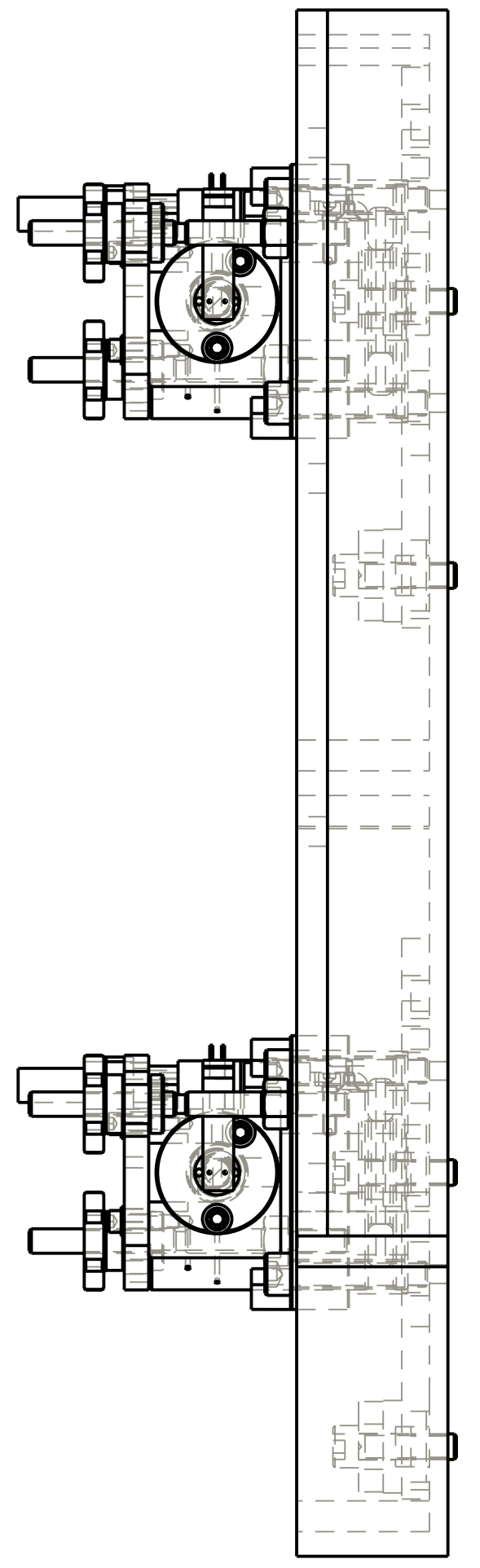

SECTION A-A

ITEM	QTY	SPARE	TOTAL	PART NUMBER	DESCRIPTION	MATERIALS
1	4			D060322	TRANSVERSE OSEM ADJUSTER	AS DRW
2	1			D080112	BS BOTTOM TABLECLOTH PLATE; BS BOTTOM TABLECLOTH; 5083 OR SIMILAR	
3	1			D080111.SKEL001		

PARTS LIST		MATERIALS	
NAME	DATE	NAME	DATE

NOTES: (UNLESS OTHERWISE SPECIFIED)

- REMOVE ALL SHARP EDGES. R:0.2 MIN.
- DO NOT SCALE FROM DRAWING.
- ALL MACHINING FLUIDS SHALL BE WATER SOLUBLE AND FREE OF SULFUR, CHLORINE AND SILICONE. SUCH AS CINCINNATI MILACRON'S CIMTECH 410 (STAINLESS STEEL).
- SCRIBE, ENGRAVE OR STAMP DRAWING PART NUMBER ON NOTED SURFACE OF PART AND A THREE DIGIT SERIAL NUMBER. SERIAL NUMBERS START AT 001 FOR THE FIRST PART AND PROCEED CONSECUTIVELY. USE 07* HIGH CHARACTERS. EXAMPLE: D080100-001 - A VIBRATOR TOOL MAY BE USED.

DIMENSIONS ARE IN mm (INCHES)

TOLERANCES:

LINEAR: ± 0.13

ANGULAR: ± 0.5

MATERIAL: AS DRW

FINISH: AS DRW

SCALE: 1:1

PROJECTION: 1ST ANGLE

PROJECT: SUS

PART NAME: BS BOTTOM TABLECLOTH BEAMSPLITTER SUSPENSION

DRG. NO.: D080111

SCALE: 1:1

PROJECTION: 1ST ANGLE

SHEET 1 OF 1