

REV.	DATE	DCN #	DRAWING TREE #
v4	08 Feb 2012	E1200180	E1200181

NOTES CONTINUED:

4. ALL MACHINING FLUIDS MUST BE FULLY SYNTHETIC, FULLY WATER SOLUBLE AND FREE OF SULFUR, SILICONE AND CHLORINE.
5. SCRIBE, ENGRAVE, OR MECHANICALLY STAMP (NO INKS OR DYES) DRAWING PART NUMBER, REVISION (AND VARIANT OR "TYPE" IF APPLICABLE) ON NOTED SURFACE OF PART FOLLOWED ON THE NEXT LINE WITH A THREE DIGIT SERIAL NUMBER. SERIAL NUMBERS START AT 001 FOR THE FIRST ARTICLE AND PROCEED CONSECUTIVELY. USE MINIMUM 0.12 HIGH CHARACTERS, UNLESS THE SIZE OF THE PART DICTATES SMALLER CHARACTERS. A VIBRATORY TOOL MAY BE USED. EXAMPLE DXXXXXXX-VY, TYPE-XX, S/N XXX.
6. APPROXIMATE WEIGHT = 38.37340 LB.
7. MACHINE ALL SURFACES TO REMOVE OXIDES AND MILL FINISH, USE OF ABRASIVE REMOVAL TECHNIQUES (INCLUDING SANDING OR SCOURING FOR MATTE FINISH) IS NOT ALLOWED. USE OF SCOTCH-BRITE OR SIMILAR PRODUCTS IS FORBIDDEN.
8. ALL PARTS SHALL BE MANUFACTURED IN ACCORDANCE WITH LIGO SPECIFICATION E0900364.
9. ALL THREADED INSERTS TO BE INSTALLED BY LIGO PERSONNEL, AFTER DELIVERY OF FINISHED PARTS, USE NITRONIC 60 THREADED INSERTS.
10. ALL HELI-COIL TAPPED HOLES TO BE PREPARED ACCORDING TO EMHART HELI-COIL PRODUCT CATALOG HC2000 CURRENT REV.
11. ALL MATERIAL IS TO BE VIRGIN MATERIAL (I.E. NOT WELD REPAIRS OR PLUGS) UNLESS APPROVED IN ADVANCE AND IN WRITING BY LIGO, REFER TO LIGO-E0900364.
12. NO REPAIRS SHALL BE MADE UNLESS APPROVED IN ADVANCE, AND IN WRITING, BY LIGO LABORATORY. IN GENERAL WELD REPAIRS AND PRESS FIT INSERT REPAIRS ARE NEVER ACCEPTABLE. THE MATERIAL USED MUST BE VIRGIN MATERIAL. SPECIAL CIRCUMSTANCES CAN BE REVIEWED IF AND WHEN BROUGHT TO THE ATTENTION OF LIGO CONTRACTING OFFICER'S REPRESENTATIVE (COTR) THROUGH THE MATERIAL REVIEW BOARD (MRB) PROCESS, REFER TO LIGO-E09000364.

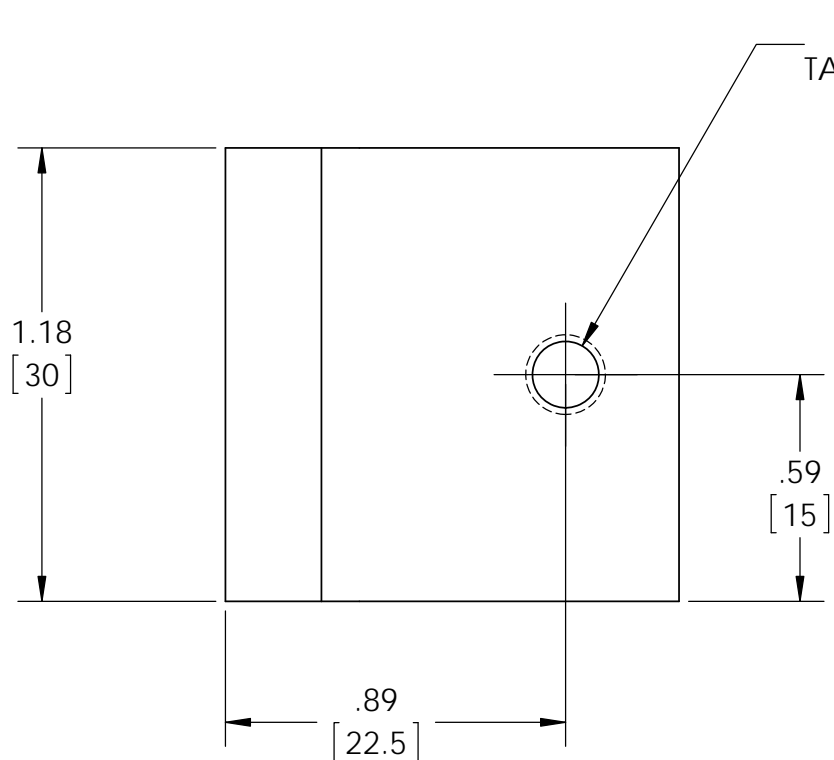
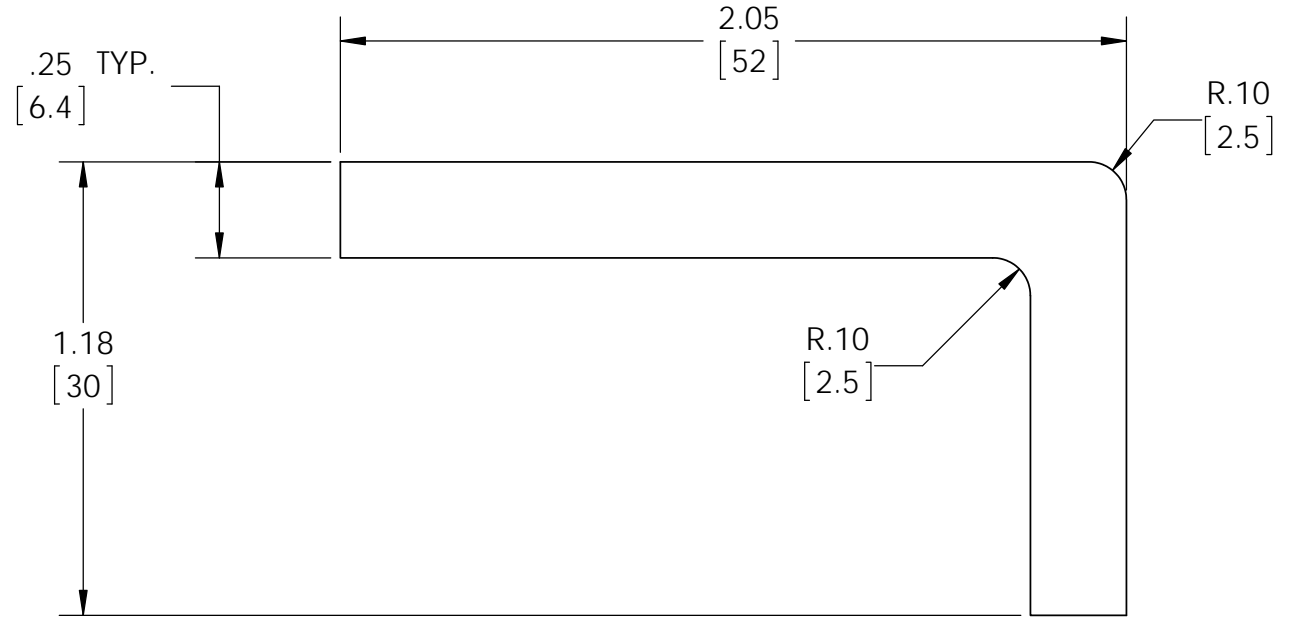

Ø .17 [4.4] THRU ALL  
TAP FOR #8-32 HELICOIL INSERT = 1.0 \* DIA.

2X Ø .17 [4.4] THRU ALL  
TAP FOR #8-32 HELICOIL INSERT = 1.0 \* DIA.

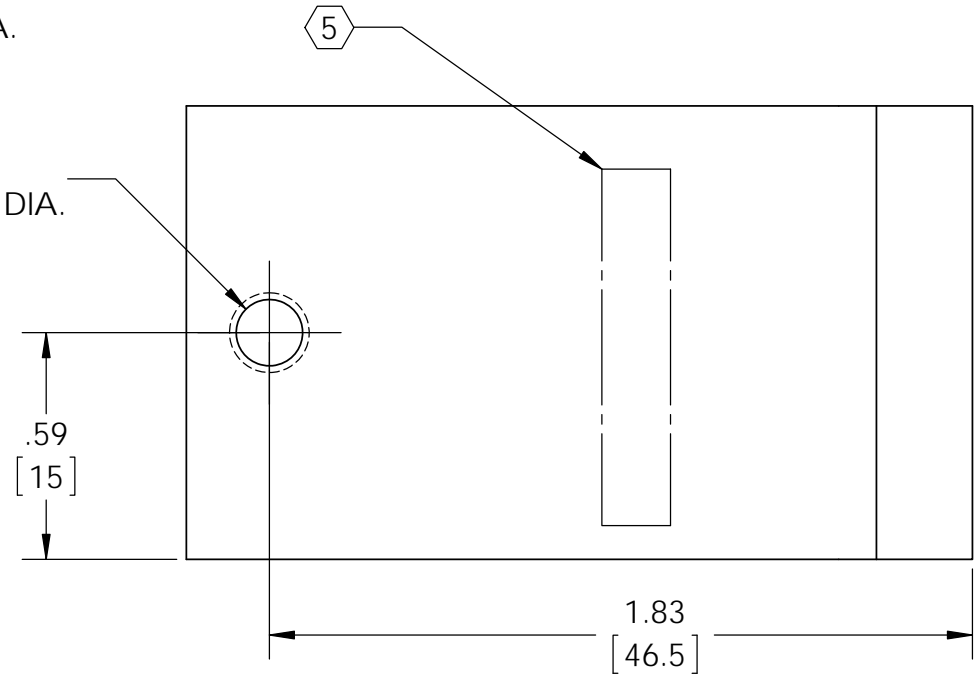

D0902518\_Angle\_Section\_10\_PART PDM REV: X-003, DRAWING PDM REV: X-001

NOTES AND TOLERANCES: (UNLESS OTHERWISE SPECIFIED)				LIGO CALIFORNIA INSTITUTE OF TECHNOLOGY MASSACHUSETTS INSTITUTE OF TECHNOLOGY		PART NAME					
DIMENSIONS ARE IN INCHES [MM]				ADVANCED LIGO		aLIGO SUS, ANGLE SECTION 10					
TOLERANCES: .XX ± .015 .XXX ± .005				SUB-SYSTEM SUS		DESIGNER	L.CUNNINGHAM	28 June 2010	SIZE	DWG. NO.	REV.
ANGULAR ± .5°				MATERIAL 6061-T6 Al		DRAFTER	L.CUNNINGHAM	30 June 2010	B	D0902518	v4
1. INTERPRET DRAWING PER ASME Y14.5-1994. 2. REMOVE ALL SHARP EDGES, .03 x 45°. 3. DO NOT SCALE FROM DRAWING.				FINISH 63 μinch		CHECKER	J.ROMIE	08 Feb 2012	SCALE: 2:1	PROJECTION:	SHEET 1 OF 1
NEXT ASSY D1102306 D1102307				APPROVAL		C.TORRIE	08 Feb 2012				