

D0902648 Spring Clamp Plate, Stage 1-2, aLIGO BSC ISI, PART PDM REV: X-026, DRAWING PDM REV: X-010

**NOTES CONTINUED:**

5. SCRIBE, ENGRAVE, OR MECHANICALLY STAMP (NO INKS OR DYES) DRAWING PART NUMBER, REVISION (AND VARIANT OR "TYPE" IF APPLICABLE) ON NOTED SURFACE OF PART FOLLOWED ON THE NEXT LINE WITH A THREE DIGIT SERIAL NUMBER. SERIAL NUMBERS START AT 001 FOR THE FIRST ARTICLE AND PROCEED CONSECUTIVELY. USE MINIMUM 0.12" HIGH CHARACTERS, UNLESS THE SIZE OF THE PART DICTATES SMALLER CHARACTERS. A VIBRATORY TOOL MAY BE USED.  
EXAMPLE: DXXXXXX-VY, TYPE-XX, S/N XXX

6. APPROXIMATE WEIGHT = 3.55 LB.

7. A TRUE POSITION TOLERANCE OF  $\phi .010$  IS - THE SAME AS A CONVENTIONAL TOLERANCE OF  $\pm .005$ .

8. MACHINE ALL SURFACES TO REMOVE OXIDES AND MILL FINISH, USE OF ABRASIVE REMOVAL TECHNIQUES IS NOT ALLOWED.

9. ALL PARTS SHALL BE MANUFACTURED IN ACCORDANCE WITH LIGO SPECIFICATION E0900364.

10. PART TO BE ELECTROPOLISHED.

11. DIMENSIONS AND TOLERANCES APPLY AFTER ELECTROPOLISHING.

REV.	DATE	DCN #	DRAWING TREE #
v1	01 Mar. 2010	E1000026	E1000025
v2	24 Aug. 2010	E1000353	E1000025

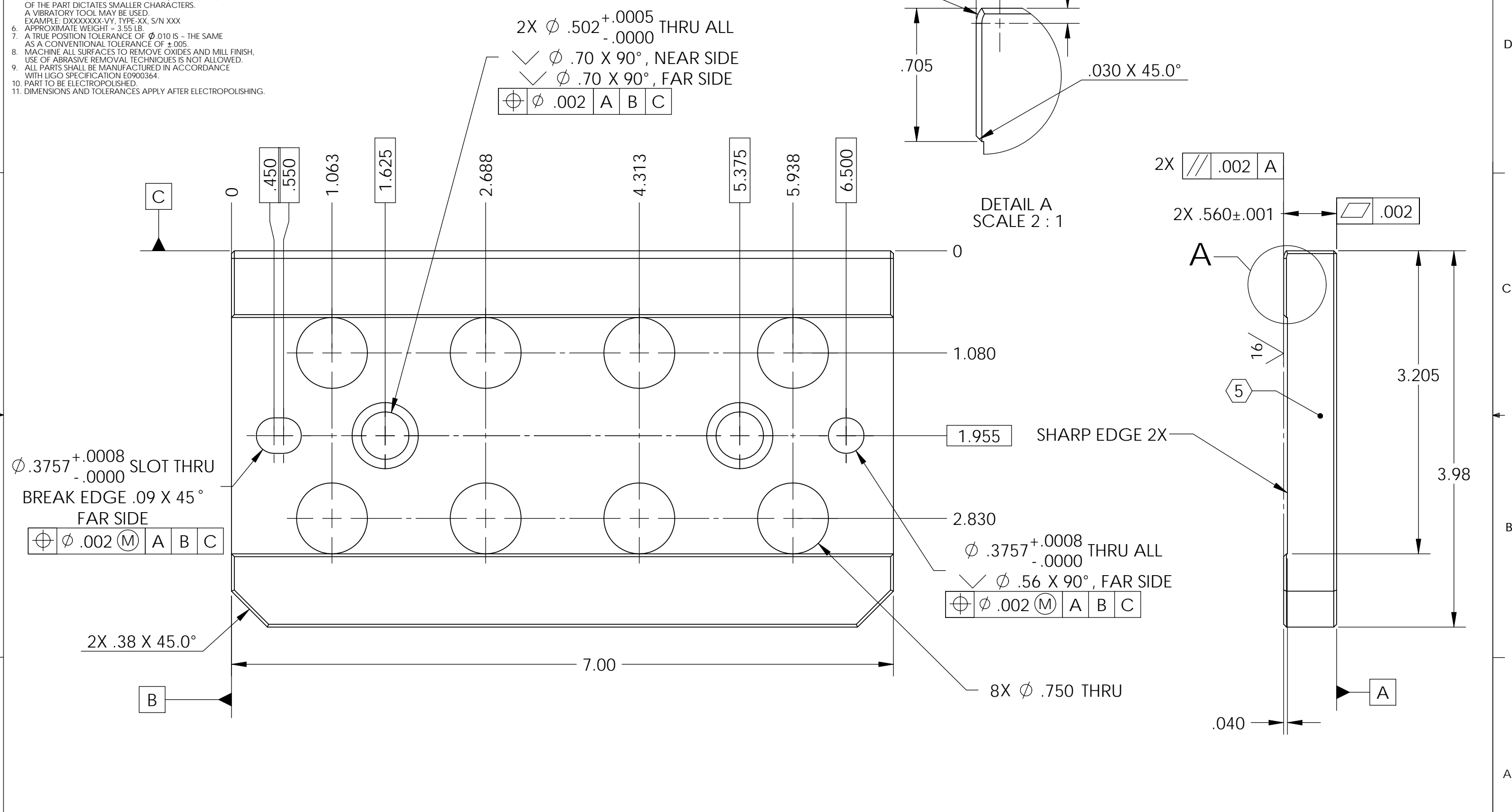

NOTES AND TOLERANCES: (UNLESS OTHERWISE SPECIFIED)				LIGO CALIFORNIA INSTITUTE OF TECHNOLOGY MASSACHUSETTS INSTITUTE OF TECHNOLOGY		PART NAME					
DIMENSIONS ARE IN INCHES				ADVANCED LIGO		Spring Clamp Plate, Stage 1-2, aLIGO BSC ISI					
TOLERANCES: .XX ± .015 .XXX ± .005				SEI		DESIGNER	A.STEIN	01 Feb. 2010	SIZE	DWG. NO.	REV.
ANGULAR ± .5°				MATERIAL		DRAFTER	M.HILLARD	01 Feb. 2010	B	D0902648	v2
				FINISH		CHECKER	MATICHARD	01 Feb. 2010	SCALE: 1:1		
				17-4 PH SSSL, H 1150		APPROVAL	K.MASON	01 Feb. 2010	PROJECTION:  SHEET 1 OF 1		
				32 μinch		NEXT ASSY		D0902485			