

NOTES CONTINUED:
 ⑤ SCRIBE, ENGRAVE, OR MECHANICALLY STAMP (NO INKS OR DYES) DRAWING PART NUMBER AND REVISION ON NOTED SURFACE FOLLOWED ON THE NEXT LINE BY A THREE DIGIT SERIAL NUMBER. SERIAL NUMBERS START AT 001 FOR THE FIRST ARTICLE AND PROCEED CONSECUTIVELY. USE 07" HIGH CHARACTERS. EXAMPLE: DXXXXXX-VY, S/N 001. A VIBRATORY TOOL MAY BE USED.
 ⑥ ITEMS 1 AND 2 CAN BE MADE FROM ONE PIECE IF DESIRED.

REV.	DATE	DCN #	DRAWING TREE #
v1	21 DEC 2009	E0900484	-
-	-	-	-
-	-	-	-

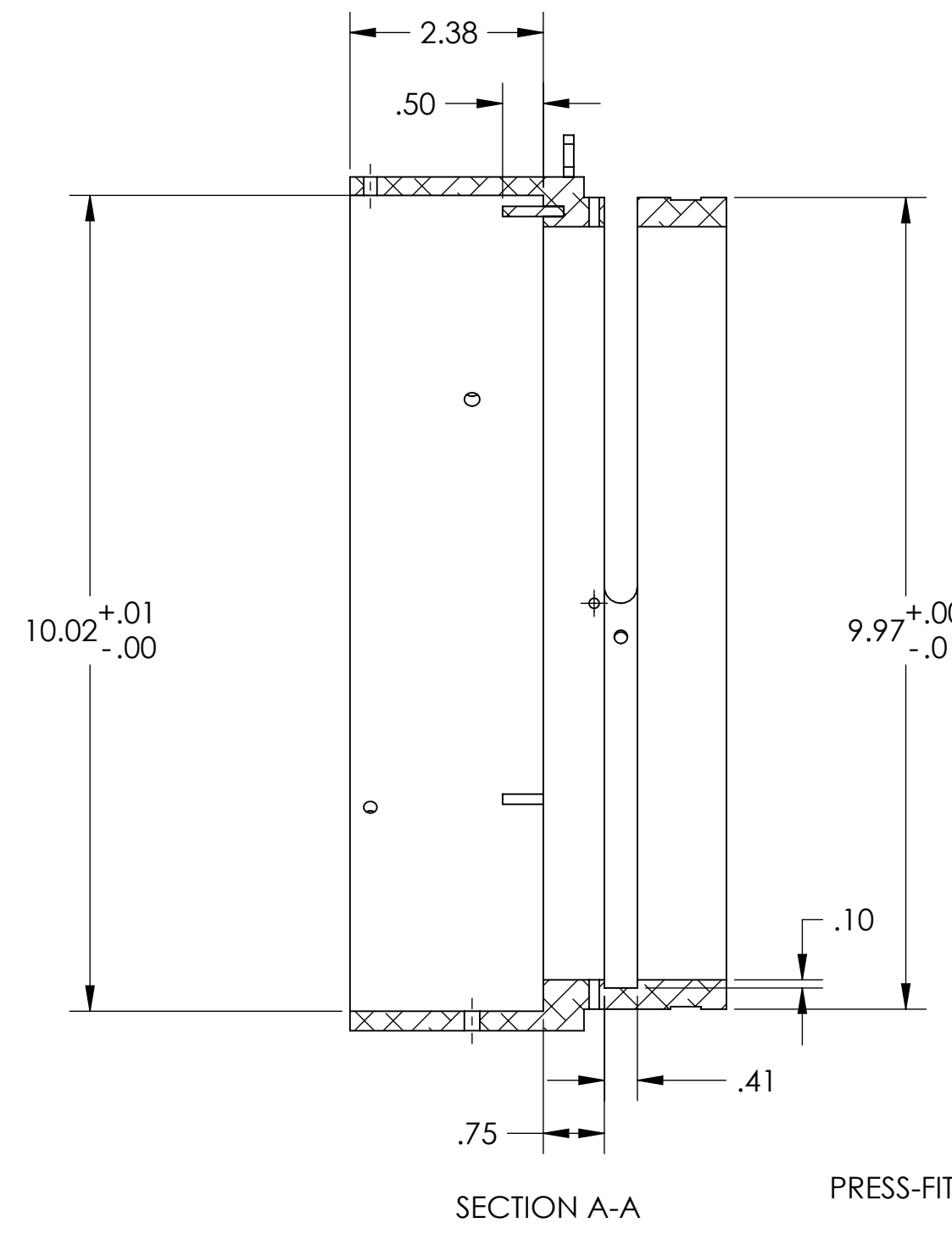

3X Ø.12 ± .0002 √.25 PRESS-FIT HOLE FOR 1/8" DOWEL PIN EVENLY SPACED

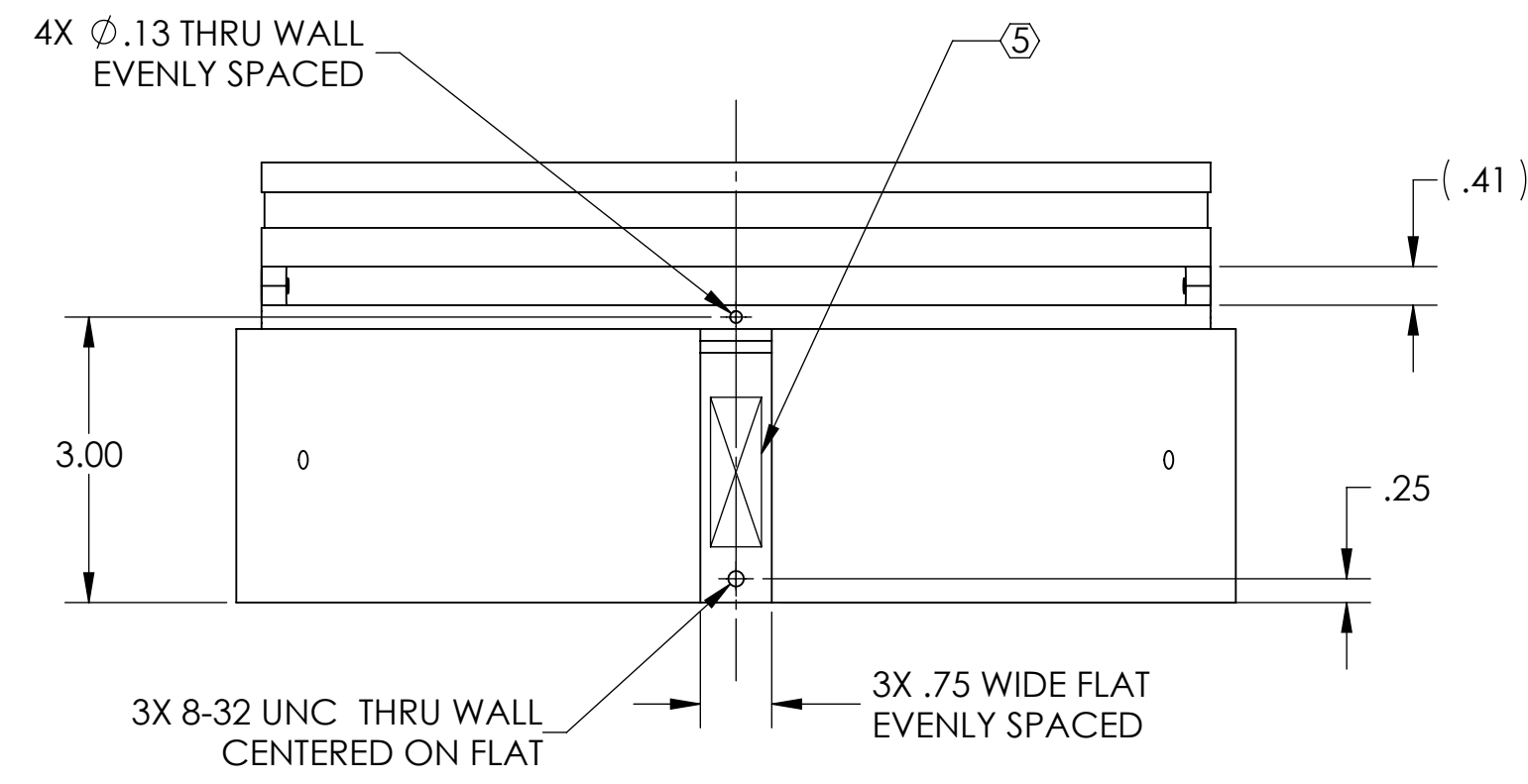
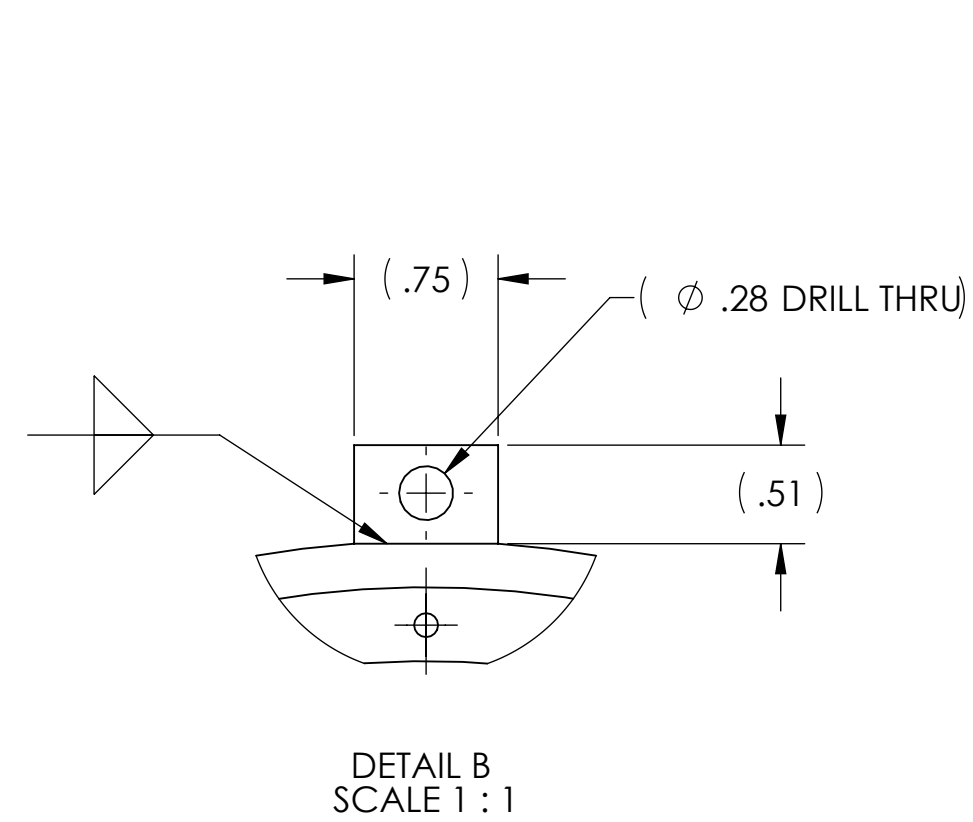
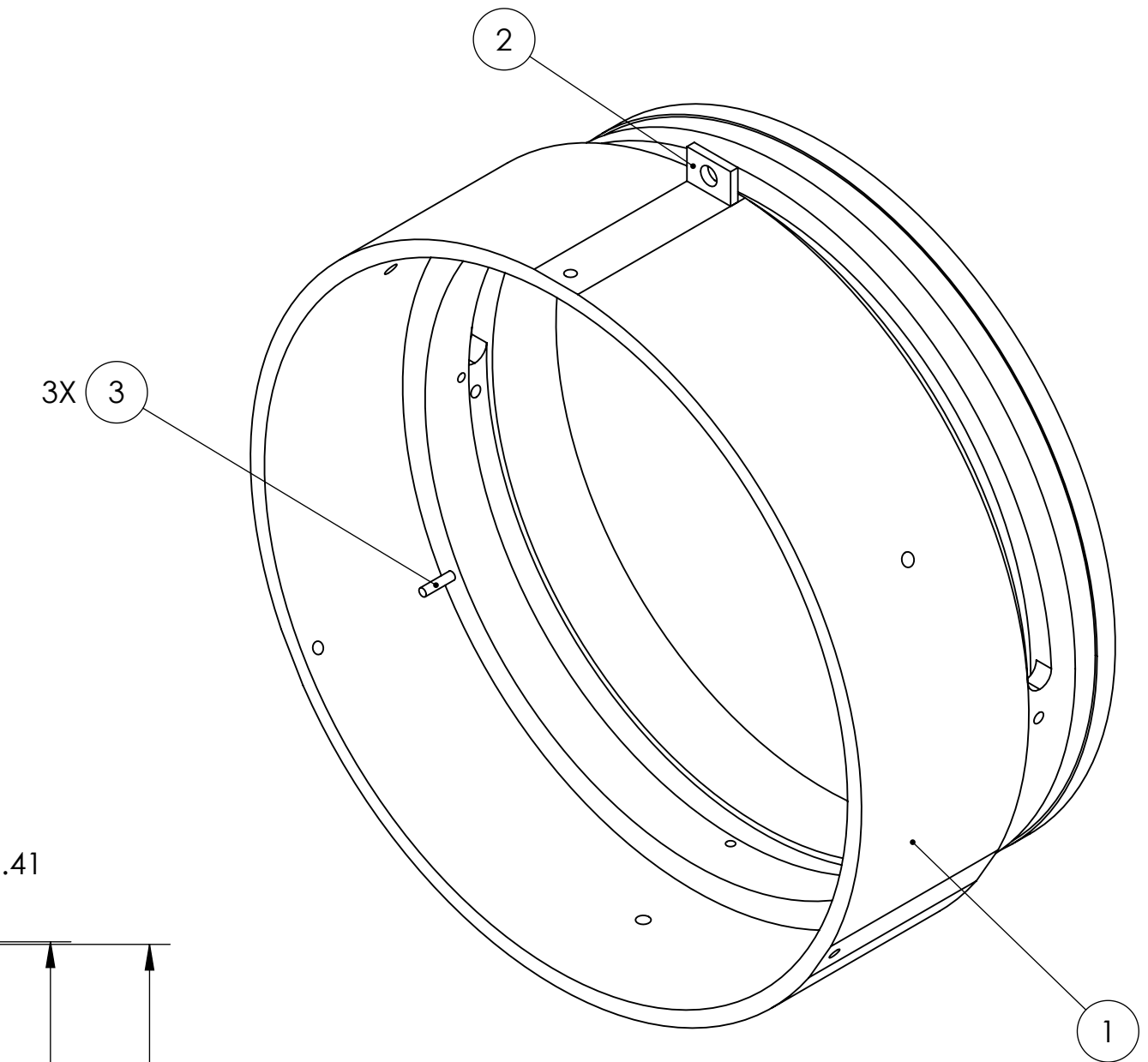
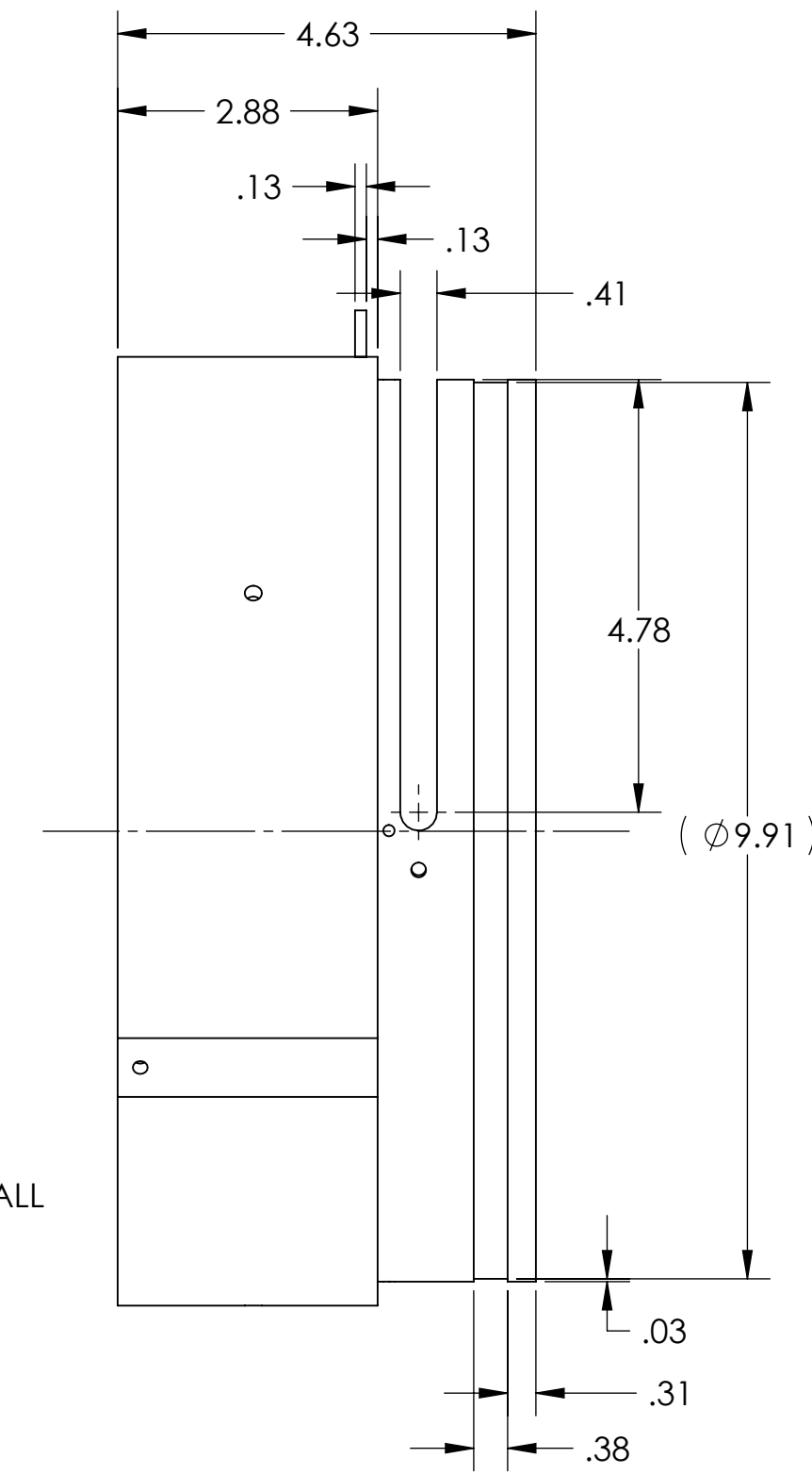
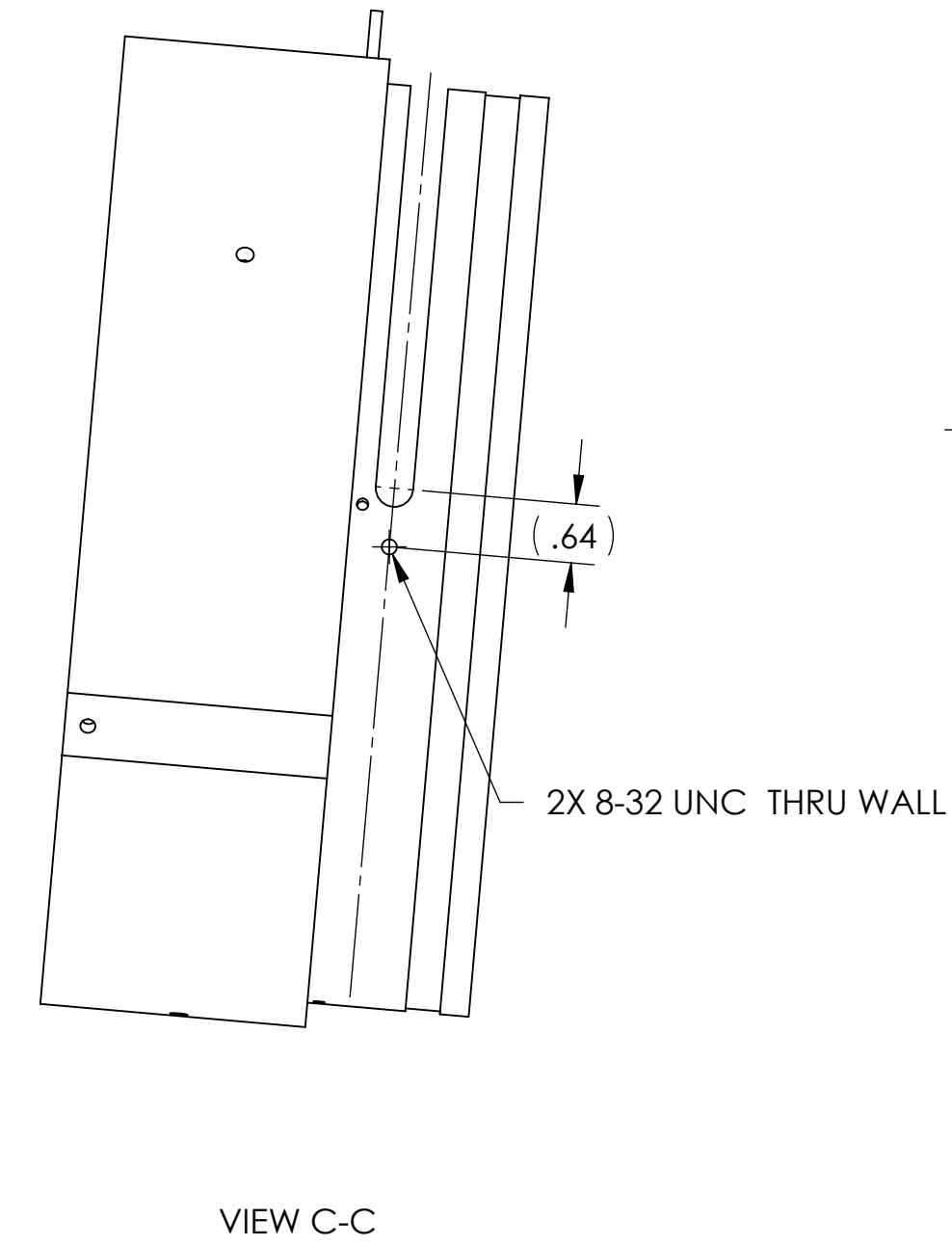
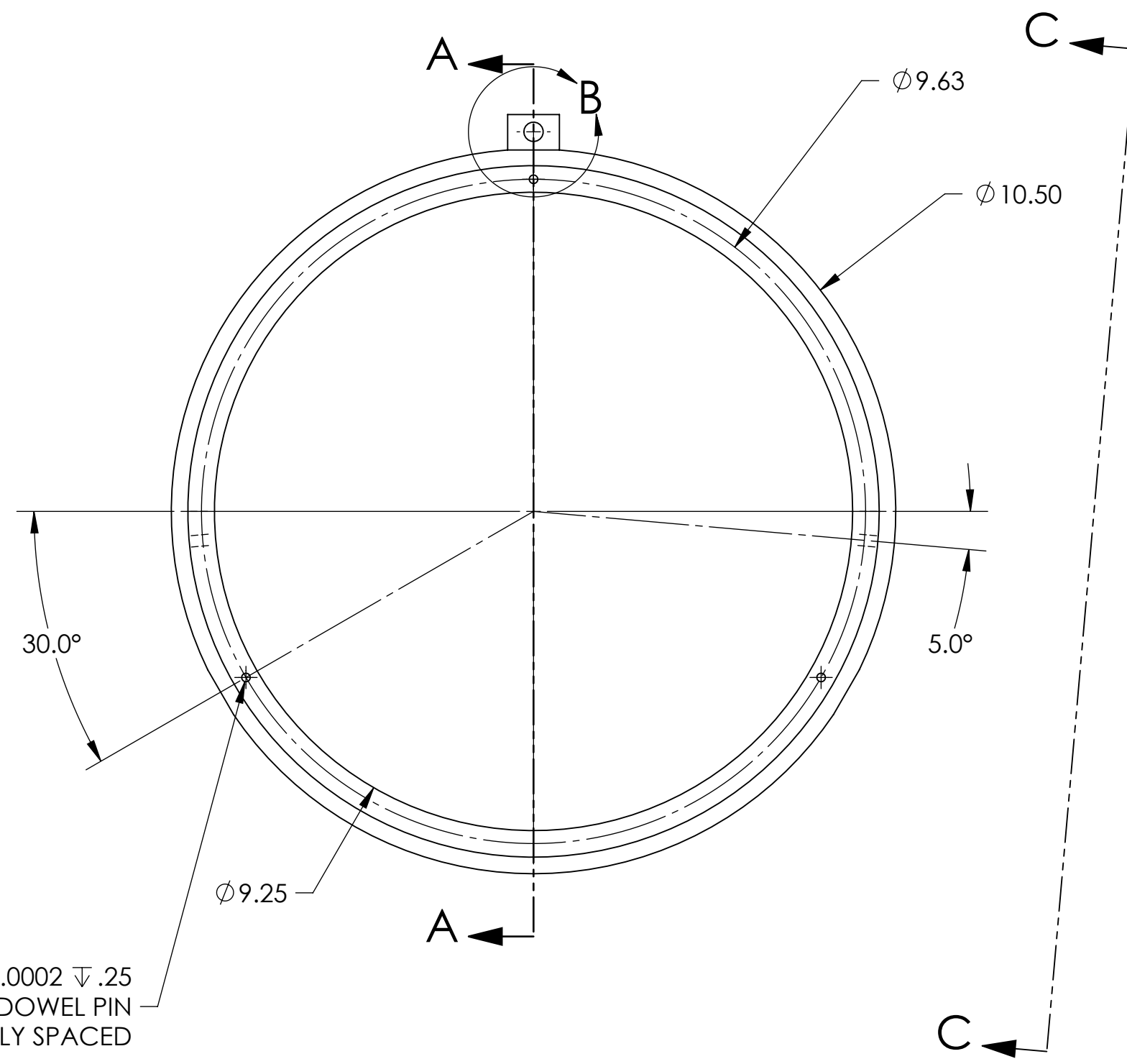

DETAIL B
SCALE 1 : 1

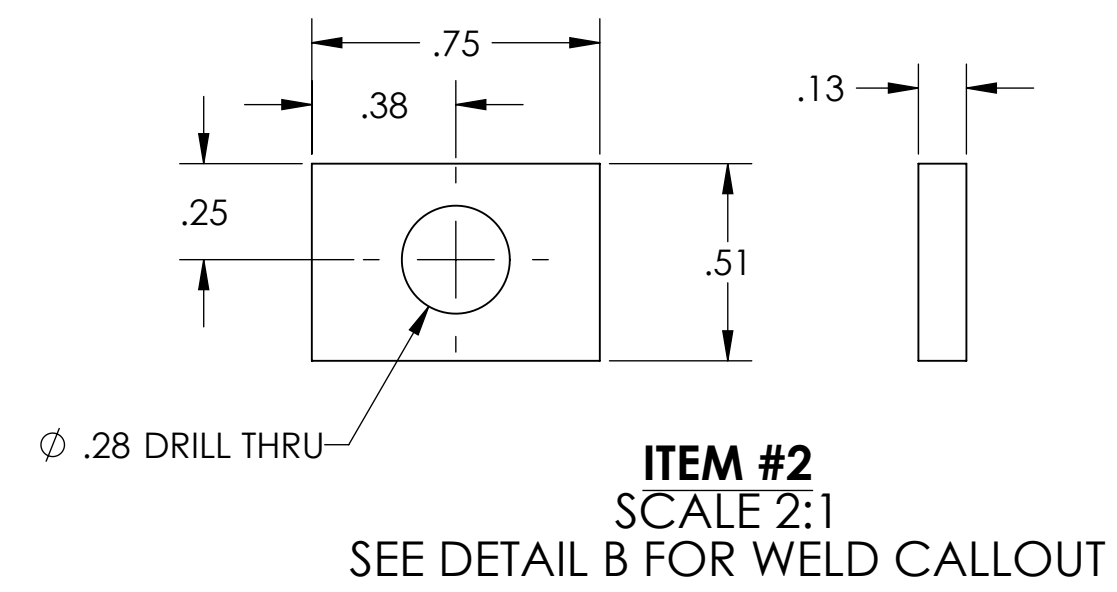
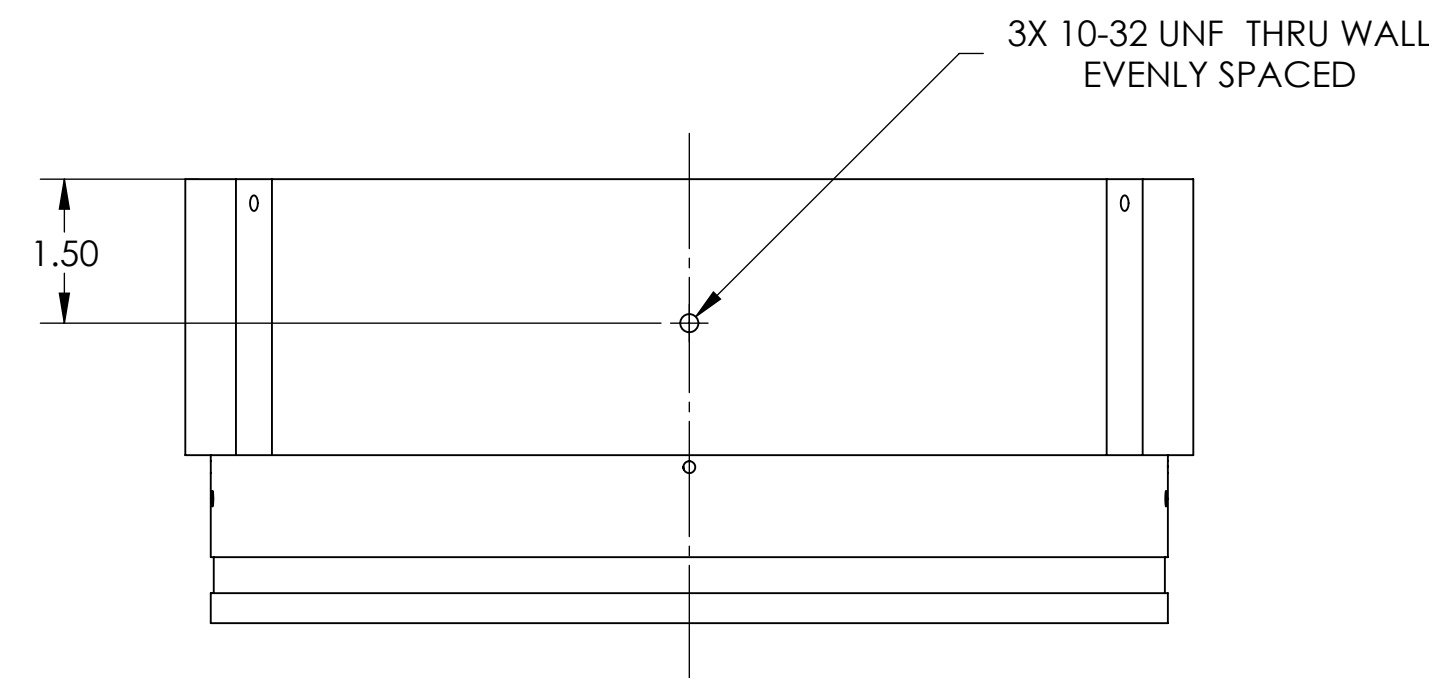

ITEM NO.	PART NUMBER	DESCRIPTION	MATERIAL	QTY
3	-	1/8" DOWEL PIN, 3/4" LONG	316 SS TL	3
2	D080365-2 ⑥	LOCKING TAB, 0.51" X 0.75" X 0.125 THICK	6061-T6 AL	1
1	D080365-1 ⑥	VIEWPORT GUARD	6061-T6 AL	1

NOTES AND TOLERANCES: (UNLESS OTHERWISE SPECIFIED)	
DIMENSIONS ARE IN INCHES	
TOLERANCES: .XX ± .01 .XXX ± .005	
ANGULAR ± 0.5°	
MATERIAL	6061-T6 AL
FINISH	SEE NOTE 4

CALIFORNIA INSTITUTE OF TECHNOLOGY MASSACHUSETTS INSTITUTE OF TECHNOLOGY	
SYSTEM	SUB-SYSTEM
ADVANCED LIGO	VE
NEXT ASSY	D080367

PART NAME			
VIEWPORT GUARD			
DESIGNER	M. MEYER	17 JUL 2008	SIZE DWG. NO.
DRAFTER	M. MEYER	04 DEC 2009	D
CHECKER	D. BRIDGES	08 DEC 2009	D080365
APPROVAL			REV. v1
SCALE: 1:2		PROJECTION:	SHEET 1 OF 1