

NOTES CONTINUED:
 3. SCRIBE, ENGRAVE, OR MECHANICALLY STAMP (NO INKS OR DYES) DRAWING PART NUMBER AND REVISION ON NOTED SURFACE FOLLOWED ON THE NEXT LINE BY A THREE DIGIT SERIAL NUMBER. SERIAL NUMBERS START AT 001 FOR THE FIRST ARTICLE AND PROCEED CONSECUTIVELY. USE 07" HIGH CHARACTERS. DXXXXXX.YY, S/N 001. EXAMPLE: A VIBRATORY TOOL MAY BE USED.
 6. APPROXIMATE WEIGHT = X.XXXX LB.
 7. MACHINE ALL SURFACES TO REMOVE OXIDES AND MILL FINISH. USE OF ABRASIVE REMOVAL TECHNIQUES IS NOT ALLOWED. REFER TO LIGO-ED900364.
 8. ALL PARTS SHALL BE MANUFACTURED IN ACCORDANCE WITH LIGO SPECIFICATION E9900364.
 9. ALL HELI-COIL HOLES TO BE PREPARED ACCORDING TO EMHART HELI-COIL PRODUCT CATALOG, HC2000, REV. 4
 10. ALL HELI-COIL INSERTS TO BE INSTALLED BY LIGO PERSONNEL AFTER DELIVERY OF FINISHED PARTS. USE NITRONIC 60 THREADED INSERTS.
 11. ALL MATERIAL IS TO BE VIRGIN MATERIAL (I.E. NO WELD REPAIRS, FLOWS OR RECYCLED MATERIAL). NO REPAIRS SHALL BE MADE UNLESS APPROVED IN ADVANCE, AND IN WRITING, BY LIGO LABORATORY. REFER TO LIGO-ED900364.
 12. SURFACE FINISH TO BE AS-PROCESSED FROM MILL/SUPPLIER, FREE FROM SCRATCHES OR GOUGES.
 13. PARTS WILL BE PORCELAIN COATED PER LIGO SPECIFICATION E100083 AFTER FABRICATION. THE INDICATED HIGLES WILL BE MASKED PRIOR TO PORCELAIN COATING TO APPROXIMATELY 2.5-3X HOLE DIAMETER CENTERED ON BOTH SIDES OF THE HOLE.
 14. DIMENSIONS APPLY BEFORE PORCELAIN COATING UNLESS SPECIFIED.
 15. BEND RADIUS: UNLESS OTHERWISE NOTED, THE BEND RADIUS SHOULD BE THE MINIMUM REQUIRED TO FORM WITHOUT CRACKING OR REQUIRING ADDITIONAL WORK WHEN FORMING. IN PARTICULAR IF SHEET METAL IS TO BE PORCELAIN COATED, THE BEND RADIUS SHALL BE A MINIMUM OF 1/2" OUTSIDE RADIUS OF BEND UNLESS OTHERWISE NOTED.
 NOTES 13 and 14 DO NOT APPLY TO THIS PART

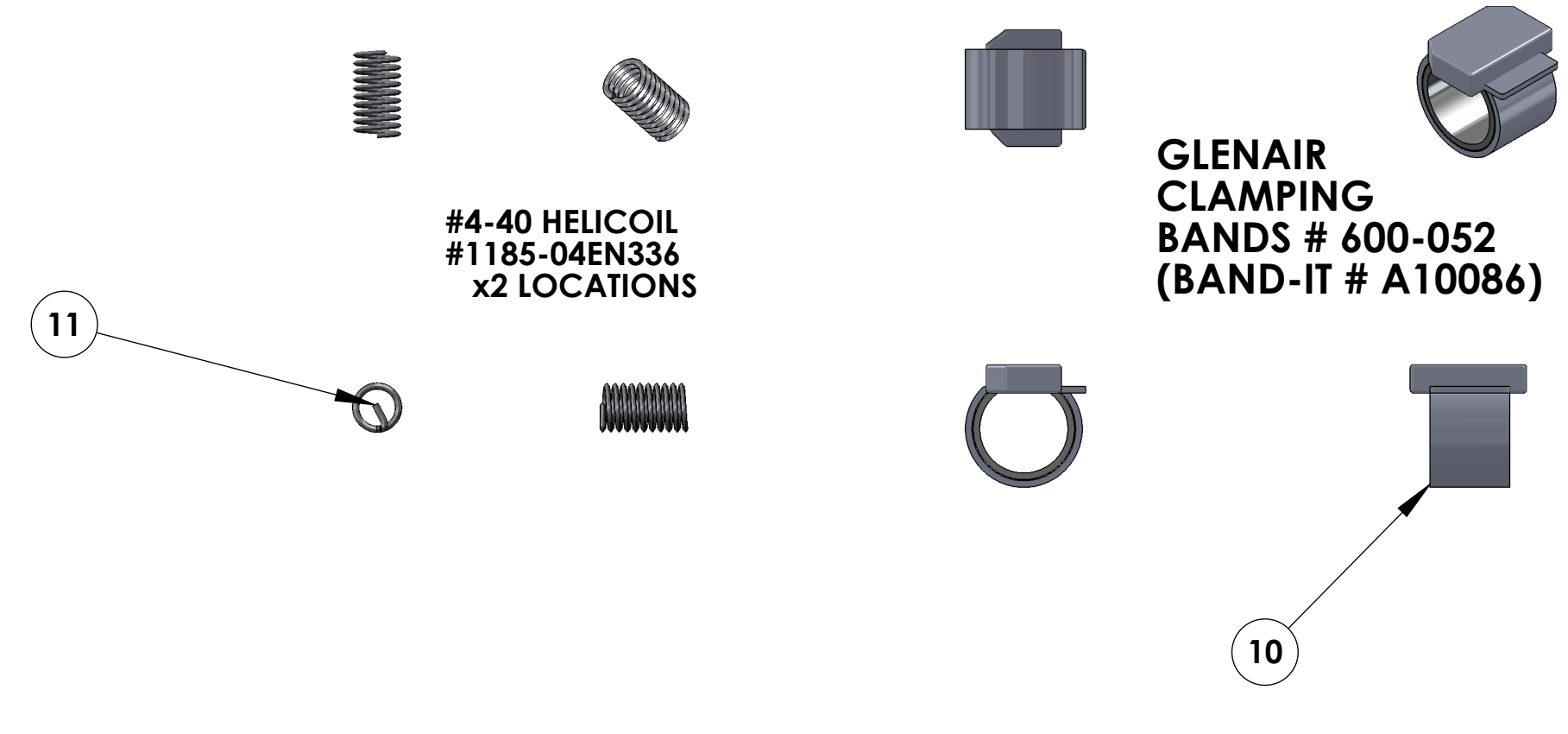

V25M CABLE ASSEMBLY CIRCUIT SUMMARY									
V-DB25 M/S1,9-36-DB9 F/S5,DB9 F/S5 RA									
FROM					TO				
CONNECTOR J1 - 25 PIN SUBMINI D MALE CONNECTOR (GOLD METALIZED PEEK)					CONNECTOR J2 - 9 PIN SUBMINI D RIGHT ANGLE FEMALE CONNECTOR (PEEK)				
PIN	WIRE NAME	COLOR	LENGTH	TWISTED PAIR	PIN	WIRE NAME	SIGNAL		
1,9,SHELL	SHIELD (BRAID)		36in.		5, SHELL	SHIELD (BRAID)	SHIELD		
1,9,SHELL	(CABLE 1) WIRE 1	White	36in.		5, SHELL	(CABLE 1) WIRE 1	SHIELD		
2	(CABLE 1) WIRE 2	White	36in.	TP-1	4	(CABLE 1) WIRE 2	POWER -		
14	(CABLE 1) WIRE 14	White	36in.	TP-1	9	(CABLE 1) WIRE 14	POWER - RTN		
3	(CABLE 1) WIRE 3	White	36in.	TP-2	3	(CABLE 1) WIRE 3	POWER +		
15	(CABLE 1) WIRE 15	White	36in.	TP-2	8	(CABLE 1) WIRE 15	POWER + RTN		
4	(CABLE 1) WIRE 4	White	36in.	TP-3	2	(CABLE 1) WIRE 4	LOCK -		
16	(CABLE 1) WIRE 16	White	36in.	TP-3	7	(CABLE 1) WIRE 16	LOCK -		
5	(CABLE 1) WIRE 5	White	36in.	TP-4	1	(CABLE 1) WIRE 5	SIG -		
17	(CABLE 1) WIRE 17	White	36in.	TP-4	6	(CABLE 1) WIRE 17	SIG -		
CONNECTOR J3 - 9 PIN SUBMINI D FEMALE CONNECTOR (PEEK)									
PIN	WIRE NAME	COLOR	LENGTH	TWISTED PAIR	PIN	WIRE NAME	SIGNAL		
1,9,SHELL	SHIELD (BRAID)		36in.		5, SHELL	SHIELD (BRAID)	SHIELD		
1,9,SHELL	(CABLE 2) WIRE 9	White	36in.		5, SHELL	(CABLE 2) WIRE 9	SHIELD		
10	(CABLE 2) WIRE 10	White	36in.	TP-5	4	(CABLE 2) WIRE 10	POWER -		
22	(CABLE 2) WIRE 22	White	36in.	TP-5	9	(CABLE 2) WIRE 22	POWER - RTN		
11	(CABLE 2) WIRE 11	White	36in.	TP-6	3	(CABLE 2) WIRE 11	POWER +		
23	(CABLE 2) WIRE 23	White	36in.	TP-6	8	(CABLE 2) WIRE 23	POWER + RTN		
12	(CABLE 2) WIRE 12	White	36in.	TP-7	2	(CABLE 2) WIRE 12	LOCK -		
24	(CABLE 2) WIRE 24	White	36in.	TP-7	7	(CABLE 2) WIRE 24	LOCK -		
13	(CABLE 2) WIRE 13	White	36in.	TP-8	1	(CABLE 2) WIRE 13	SIG -		
25	(CABLE 2) WIRE 25	White	36in.	TP-8	6	(CABLE 2) WIRE 25	SIG -		

TEST LIST		
FROM	TO	
J1	J2	
PIN	PIN	
J1 - 1,9,SHELL	J2 - 5, SHELL	
J1 - 1,9,SHELL	J2 - 5, SHELL	
J1 - 2	J2 - 4	
J1 - 14	J2 - 9	
J1 - 3	J2 - 3	
J1 - 15	J2 - 8	
J1 - 4	J2 - 2	
J1 - 16	J2 - 7	
J1 - 5	J2 - 1	
J1 - 17	J2 - 6	
J1	J3	
PIN	PIN	
J1 - 1,9,SHELL	J3 - 5, SHELL	
J1 - 1,9,SHELL	J3 - 5, SHELL	
J1 - 10	J3 - 4	
J1 - 22	J3 - 9	
J1 - 11	J3 - 3	
J1 - 23	J3 - 8	
J1 - 12	J3 - 2	
J1 - 24	J3 - 7	
J1 - 13	J3 - 1	
J1 - 25	J3 - 6	

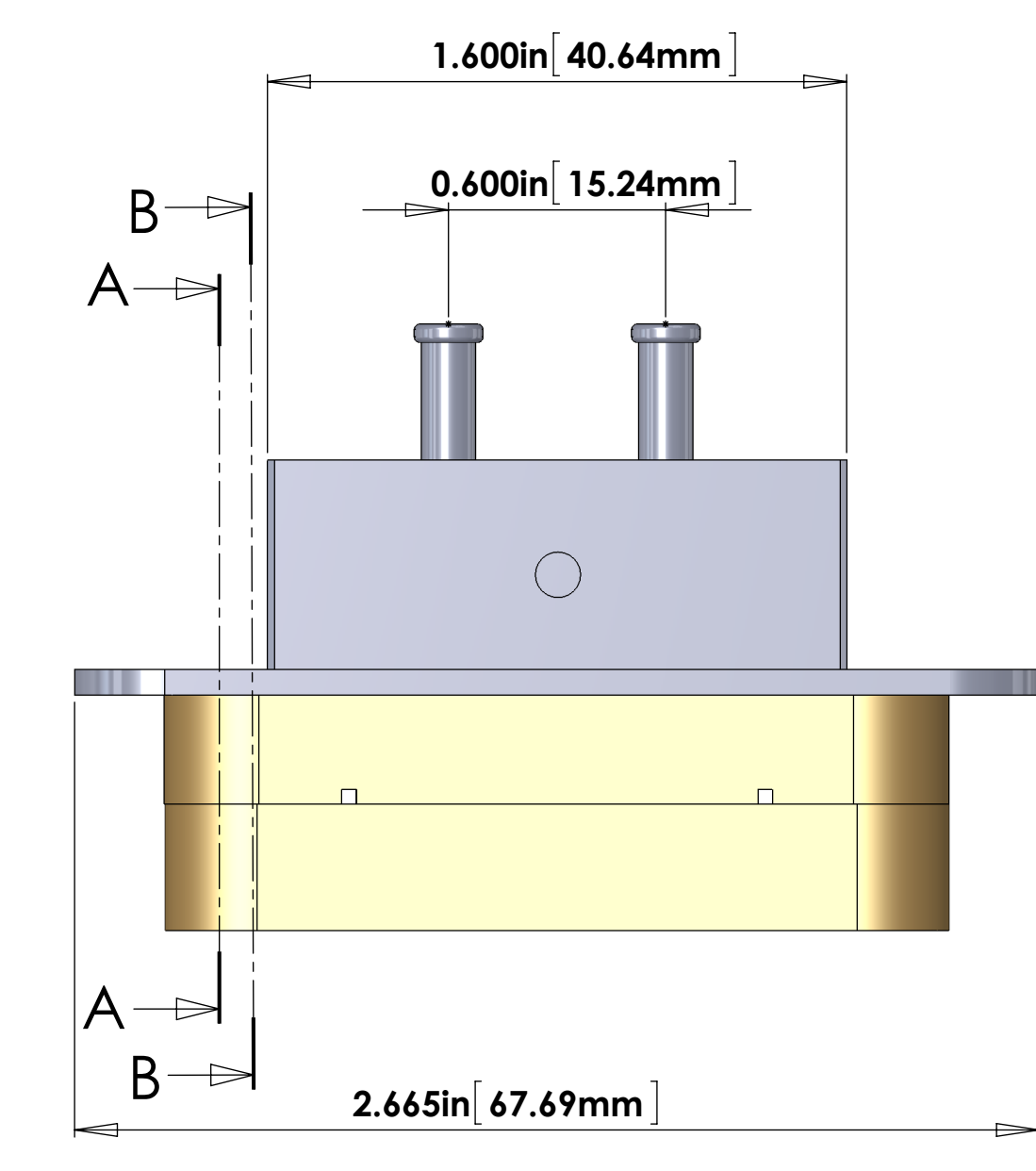
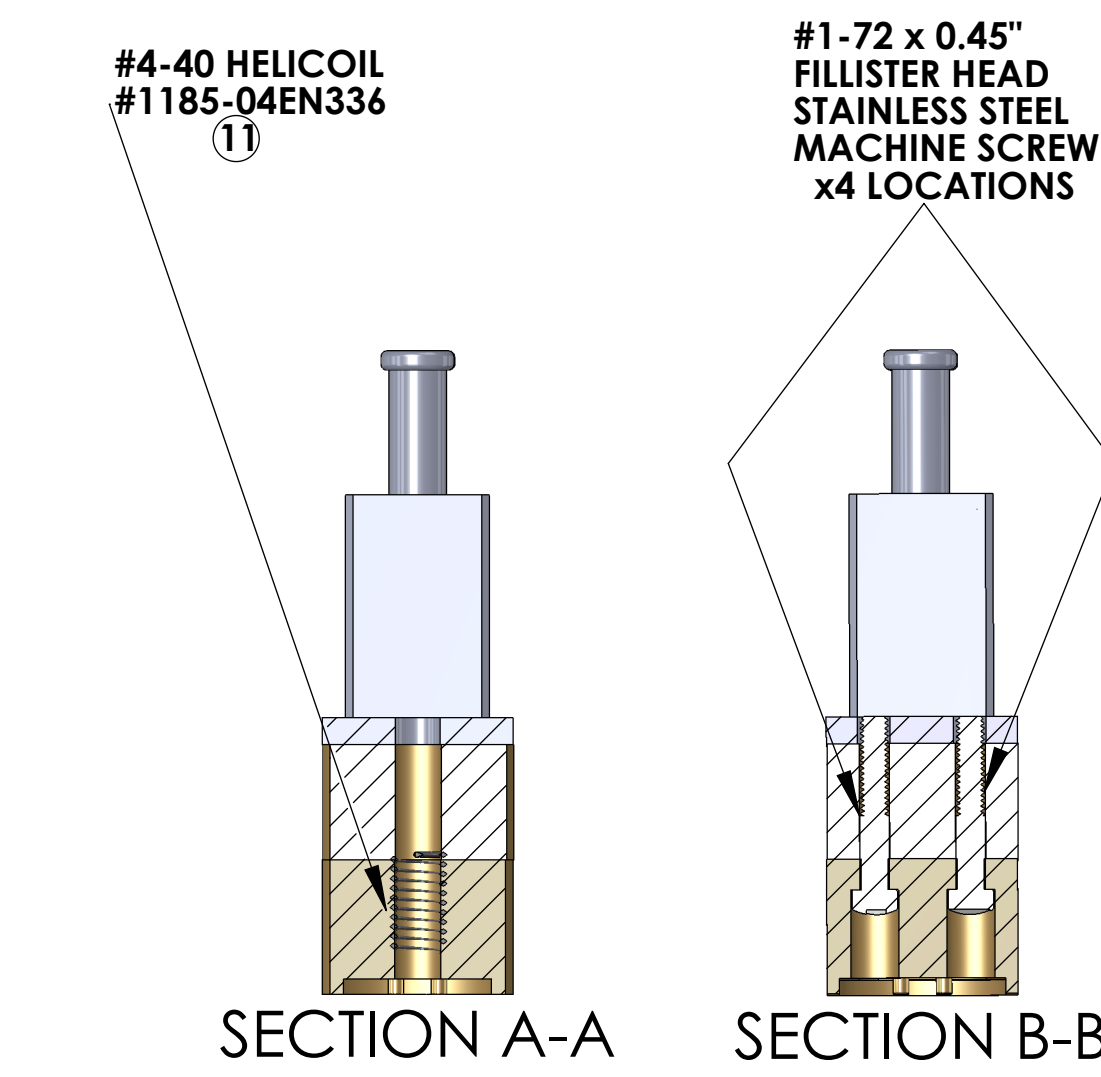
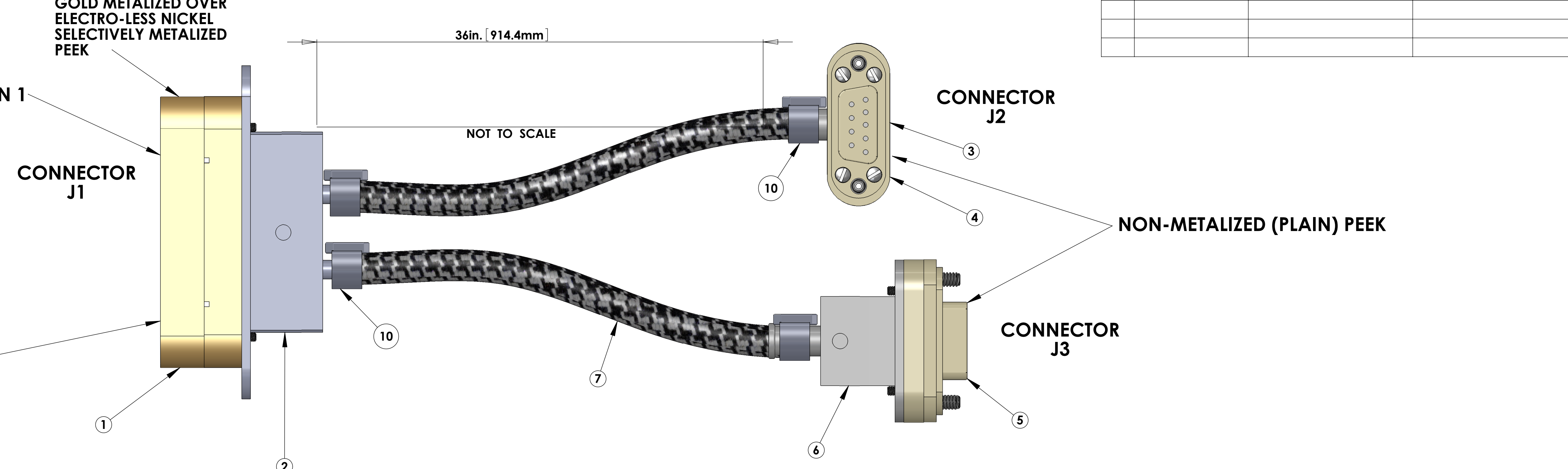
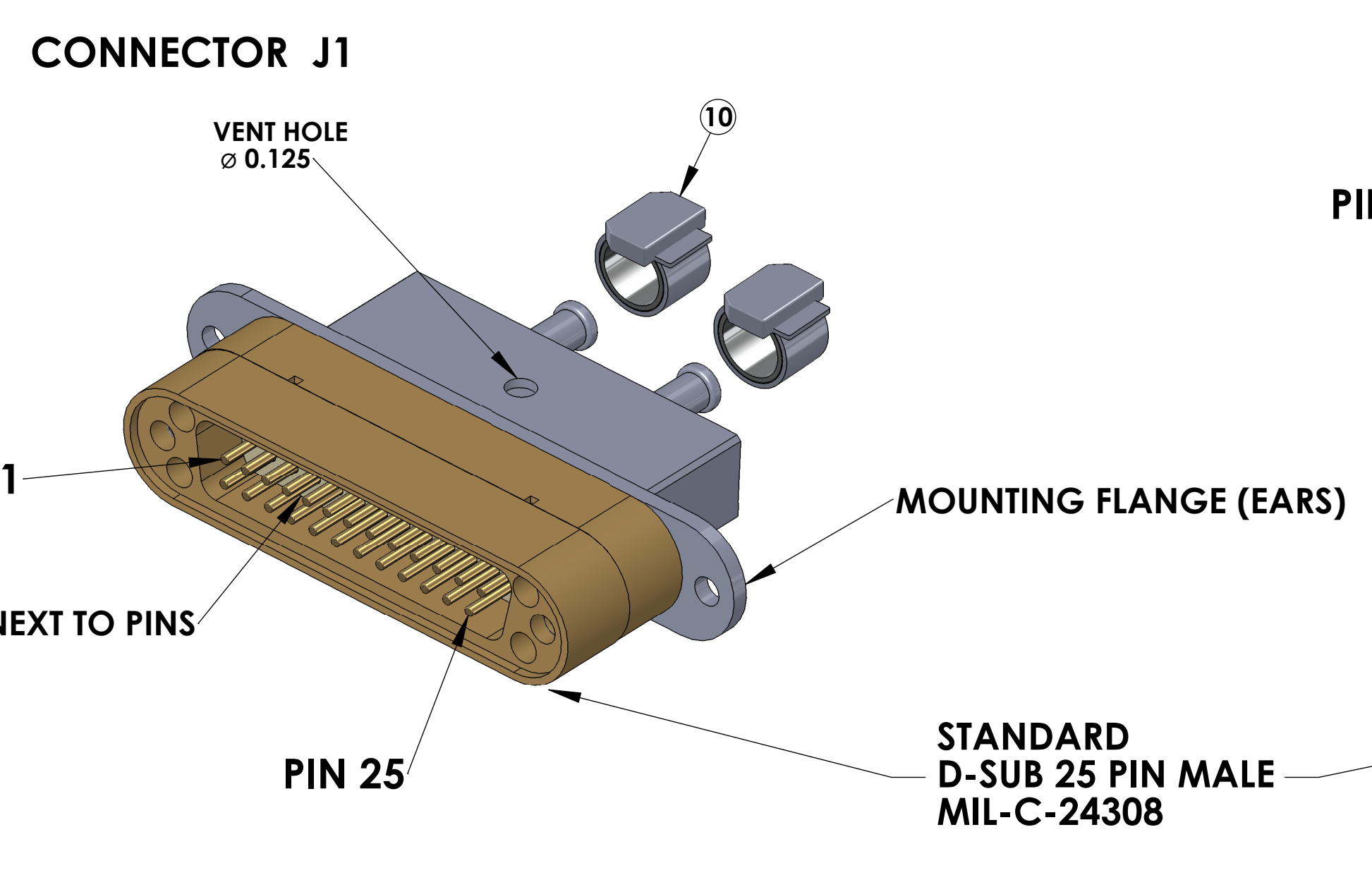
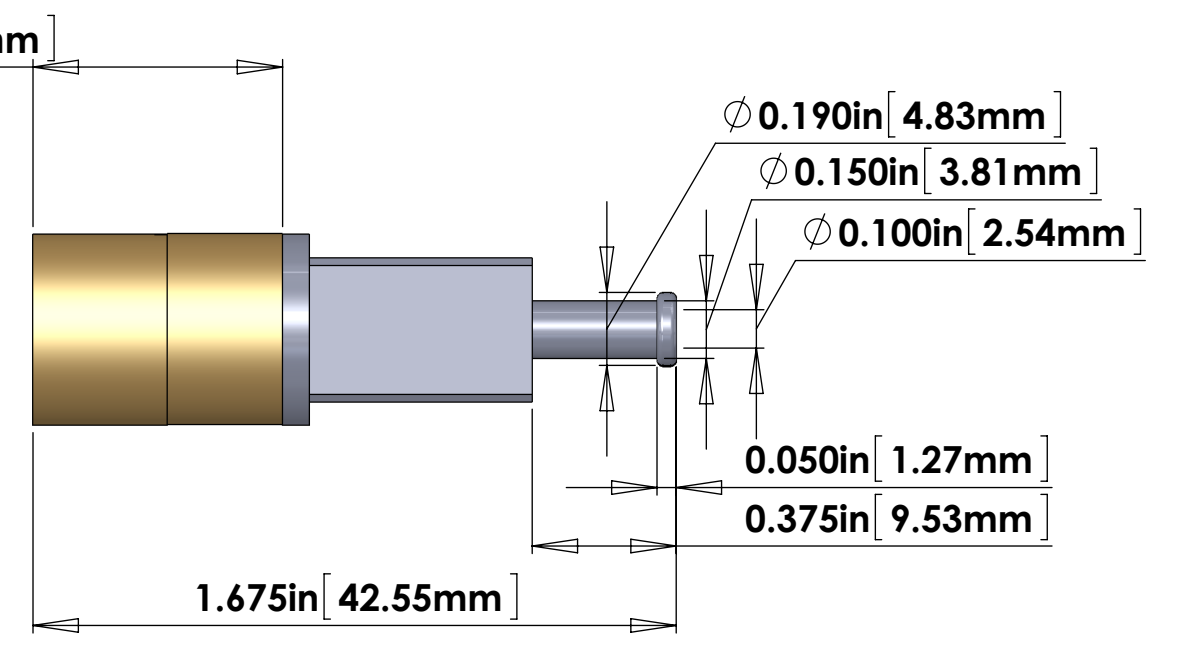
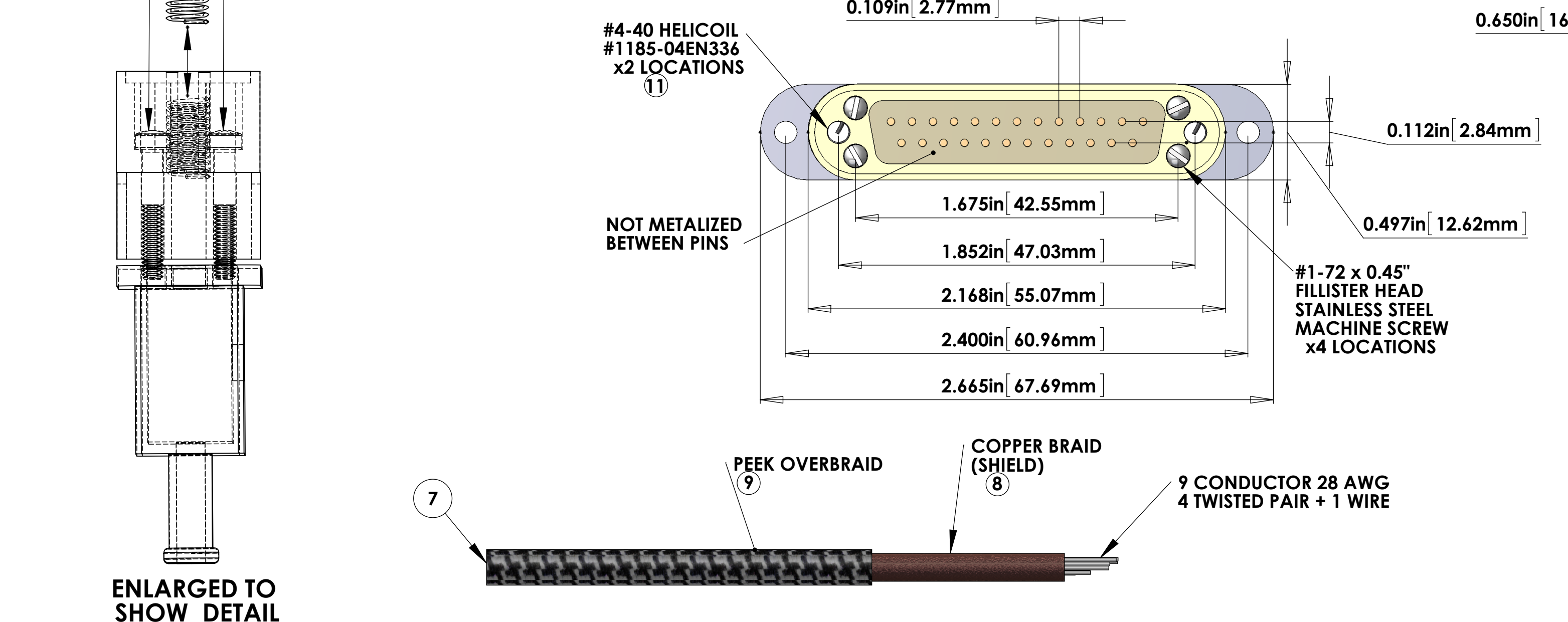

BILL OF MATERIALS				
ITEM NO.	PART NUMBER	DESCRIPTION	QTY.	LENGTH *
1	TICOR # TS0149-25CG20B32-100F OR EQUIVALENT **	CUSTOM DB25 MALE CONNECTOR (J1) FOR UHV (GOLD METALIZED PEEK)	1	
2	TICOR # TS0149-25CG20B32-100F OR EQUIVALENT **	CUSTOM DB25 CONNECTOR BACKSHELL FOR UHV (STAINLESS) WITH DUAL Ø0.100" i.d. PORTS	1	
3	TICOR # TS0148-9C020B11-188 (TS0122-0901) OR EQUIVALENT **	DB9 RIGHT ANGLE FEMALE CONNECTOR (J2) FOR UHV (PEEK)	1	
4	TICOR # TS0148-9C020B11-188 (TS0122-0901) OR EQUIVALENT **	DB9 CONNECTOR BACKSHELL FOR UHV (STAINLESS) WITH Ø0.188" i.d. PORT	1	
5	TICOR # TS0148-9C020B51-188 (TS0122-0902) OR EQUIVALENT **	DB9 FEMALE CONNECTOR (J3) FOR UHV (PEEK)	1	
6	TICOR # TS0148-9C020B51-188 (TS0122-0902) OR EQUIVALENT **	DB9 CONNECTOR BACKSHELL FOR UHV (STAINLESS) WITH Ø0.188" i.d. PORT	1	
7	C1	9 COND. (4 TW PAIR + 1 WIRE + SHIELD) CABLE WITH 8 COPPER BRAID (SHIELD) AND 9 PEEK OVERBRAID	2	
8	CONTINENTAL PART #24x3x40BC	COPPER BRAID - CONTINENTAL CORDAGE PART # 24x3x40BC	2	36" *
9	PEEK BRAID PART #6759	PART #6759 MANUFACTURED WITH ZEUS 0.016" BLACK PEEK DRAWN MONOFILAMENT	2	
10	GLENAIR # 600-052 or BAND-IT # A10086	GLENAIR # 600-052 STANDARD BRAID CLAMP or BAND-IT PART # A10086 (0.240" WIDE) ("BAG OF 100" # A10089)	4	
11	HELICOIL #1185-04EN336	#4-40 Nitronic 60® HELICOIL 0.336" LENGTH	2	

* NOTE: USE WHATEVER LENGTH IS NECESSARY FOR THE INTERNAL WIRING OF THE CONNECTORS AND STRIP LENGTH TO ACHIEVE THE CORRECT OVERALL LENGTHS.
 ** NOTE: SEE THE "TICOR CONNECTOR PART NUMBER BUILDER" DCC#D1000219 FOR DETAILS ON THIS PART NUMBER.
 ELECTRICAL NOTES: (UNLESS OTHERWISE SPECIFIED)
 A. MATERIAL: a. J1 CONNECTOR SHELL - GOLD OVER ELECTRO-LESS NICKEL SELECTIVELY METALIZED PEEK VICTREX 450GL30. b. J2 CONNECTOR SHELL - PEEK VICTREX 450GL30. c. J3 CONNECTOR SHELL - PEEK VICTREX 450GL30. d. BACKSHELL - STAINLESS STEEL WITH VENT HOLE. e. CONTACTS - BERYLLIUM COPPER ALLOY C17300. 0.00050 MIN. GOLD OVER NICKEL. f. HARDWARE: STAINLESS STEEL, PASSIVATED. g. PEEK BRAID - PEEK VICTREX GRADE TDS-450CA30 CARBON LOADED - SUPPLIED BY LIGO.
 B. CABLE 9 COND. 28 AWG (40 STRD 44 AWG) WITH 2 LAYERS OF KAPTON TAPE. (SUPPLIED BY LIGO). 4 TWISTED PAIRS (4 TO 5 TWISTS PER INCH) + 1 WIRE. OVERALL 40AWG COPPER BRAID 50% COVERAGE (SUPPLIED BY LIGO). OVERALL PEEK BRAID MIN. 50% COVERAGE (SUPPLIED BY LIGO). OVERALL CABLE O.D. WILL BE APPROX. 0.240 IN.
 C. CONNECTORS WILL BE SUPPLIED WITH HARDWARE. LENGTH OF SCREWS SHOULD BE THE PROPER LENGTH FOR MATING.

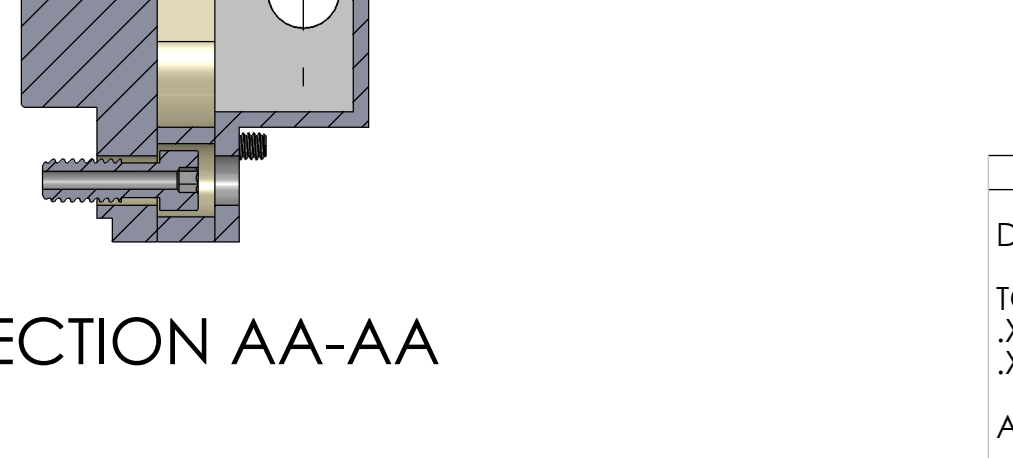
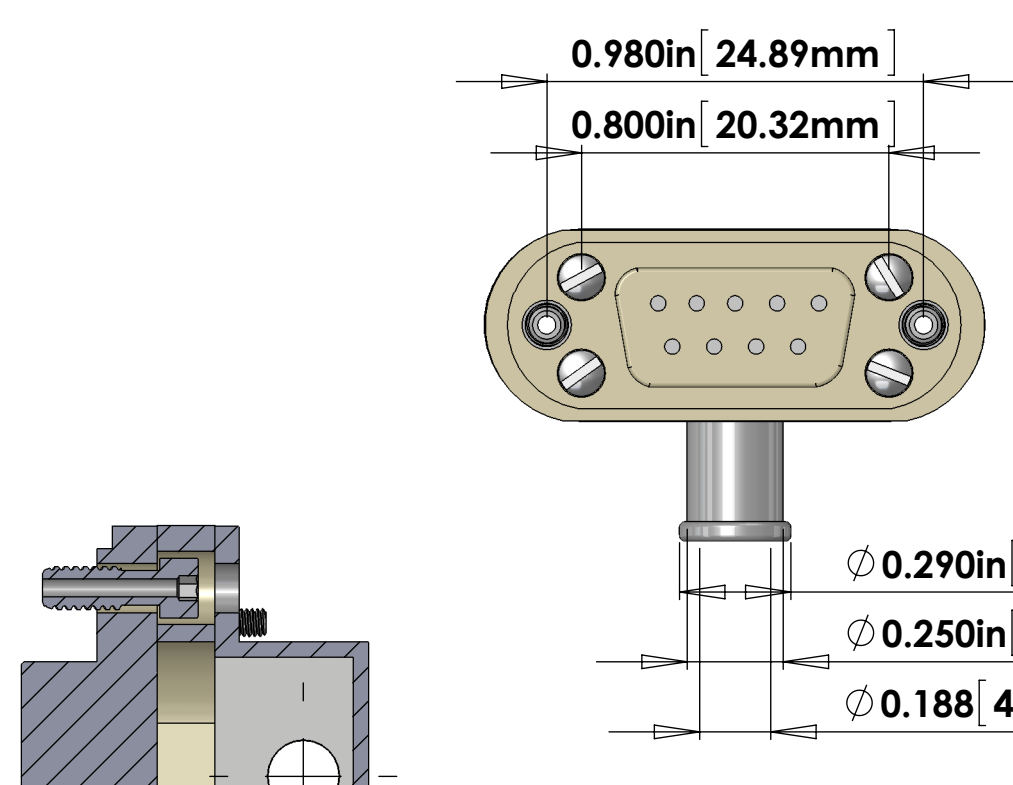
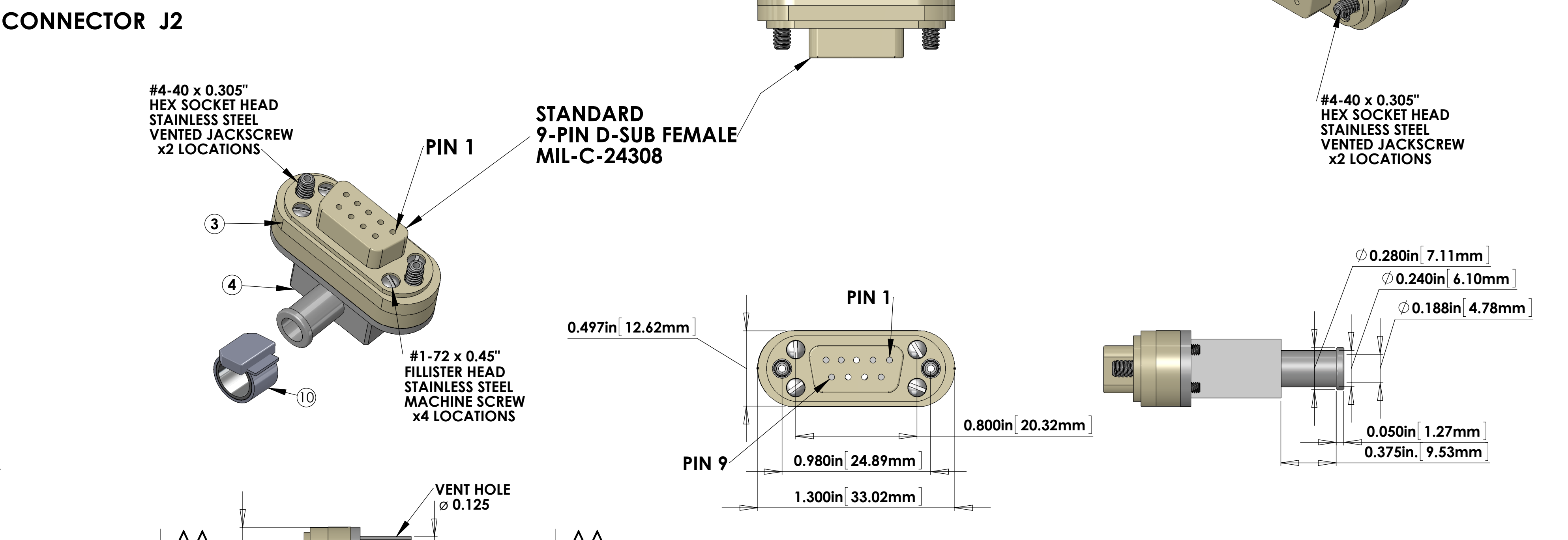
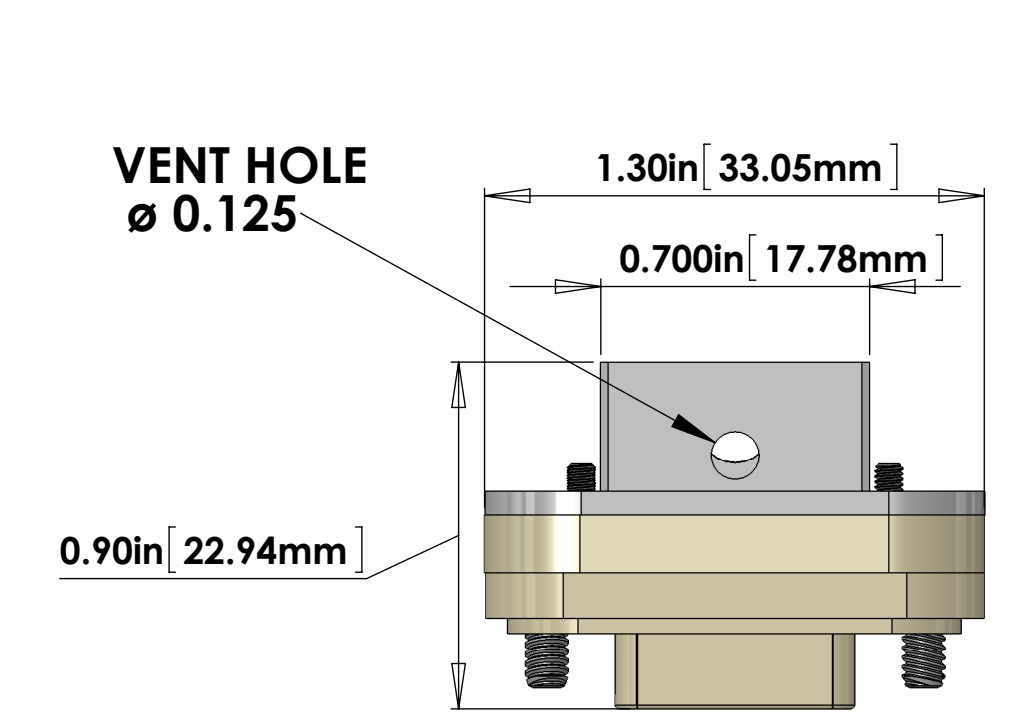

SEI GS-13 AND L-4C SEISMOMETER CABLE FROM CONNECTOR MOUNT TO SEISMOMETER									
V-DB25 M/S1,9-36-DB9 F/S5,DB9 F/S5 RA									
STANDARD USE FOR THIS CABLE									
SUBSYSTEM	AIR/VAC	STANDARD USE							
SEI	IN-VAC	GS-13,L-4C							
NOTES AND TOLERANCES: (UNLESS OTHERWISE SPECIFIED) 1. INTERPRET DRAWING PER ASME Y14.5-1994. 2. REMOVE ALL SHARP EDGES. 0.05-0.15. FOR MACHINED PARTS. ROUND ALL EDGES APPROXIMATELY R/2 FOR SHEET METAL PARTS. 3. DO NOT SCALE FROM DRAWING. 4. ALL MACHINING FLUIDS MUST BE FULLY SYNTHETIC, FULLY WATER SOLUBLE AND FREE OF SULFUR, SILICONE, AND CHLORINE. MATERIAL: N/A FINISH: N/A µinch									
CALIFORNIA INSTITUTE OF TECHNOLOGY MASSACHUSETTS INSTITUTE OF TECHNOLOGY		PART NAME CUSTOM CABLE SPECIFICATION V25M-36		DESIGNER: B. ABBOTT JUN/29/2012 DRAFTER: E. BROWN JUN/29/2012		SIZE: DWG. NO. E D1000227		REV. v9	
SYSTEM: SEI		SUB-SYSTEM: SEI		CHECKER:		APPROVAL:		SCALE: 2:1 PROJECTION:	