

- NOTES CONTINUED:
- SCRIBE, ENGRAVE, OR MECHANICALLY STAMP (NO INKS OR DYES) DRAWING PART NUMBER AND REVISION ON NOTED SURFACE FOLLOWED ON THE NEXT LINE BY A THREE DIGIT SERIAL NUMBER. SERIAL NUMBERS START AT 001 FOR THE FIRST ARTICLE AND PROCEED CONSECUTIVELY. USE 07" HIGH CHARACTERS. EXAMPLE: DXXXXXXV, S/N 001. VIBRATORY TOOL MAY BE USED.
 - APPROXIMATE WEIGHT = X.XXXX LB.
 - MACHINE ALL SURFACES TO REMOVE OXIDES AND MILL FINISH. USE OF ABRASIVE REMOVAL TECHNIQUES IS NOT ALLOWED. REFER TO LIGO E0900364.
 - ALL PARTS SHALL BE MANUFACTURED IN ACCORDANCE WITH LIGO SPECIFICATION E0900364.
 - ALL HELI-COIL HOLES TO BE PREPARED ACCORDING TO EMMART HELI-COIL PRODUCT CATALOG, HC2000, REV 4.
 - ALL HELI-COIL INSERTS TO BE INSTALLED BY LIGO PERSONNEL AFTER DELIVERY OF FINISHED PARTS. USE NITRONIC 60 THREADED INSERTS.
 - ALL MATERIAL IS TO BE VIRGIN MATERIAL (i.e. NO WELD REPAIRS, PLUGS OR RECYCLED MATERIAL). NO REPAIRS SHALL BE MADE UNLESS APPROVED IN ADVANCE AND IN WRITING, BY LIGO LABORATORY. REFER TO LIGO E0900364.
 - SURFACE FINISH TO BE AS-PROCESSED FROM MILL/SUPPLIER, FREE FROM SCRATCHES OR GOUGES.
 - PART WILL BE PORCELAIN COATED PER LIGO SPECIFICATION E1000083 AFTER FABRICATION. THE INDICATED HOLES WILL BE MASKED PRIOR TO PORCELAIN COATING TO APPROXIMATELY 2.5-3X HOLE DIAMETER CENTERED ON BOTH SIDES OF THE HOLE.
 - DIMENSIONS APPLY BEFORE PORCELAIN COATING UNLESS SPECIFIED.
 - BEND RADIUS, UNLESS OTHERWISE NOTED. THE BEND RADIUS SHOULD BE THE MINIMUM REQUIRED TO FORM WITHOUT CRACKING OR REQUIRING ADDITIONAL WORK WHEN FORMING. IN PARTICULAR IF SHEET METAL IS TO BE PORCELAIN COATED, THE BEND RADIUS SHALL BE A MINIMUM OF .12" OUTSIDE RADIUS OF BEND UNLESS OTHERWISE NOTED.

NOTES 13 and 14 DO NOT APPLY TO THIS PART

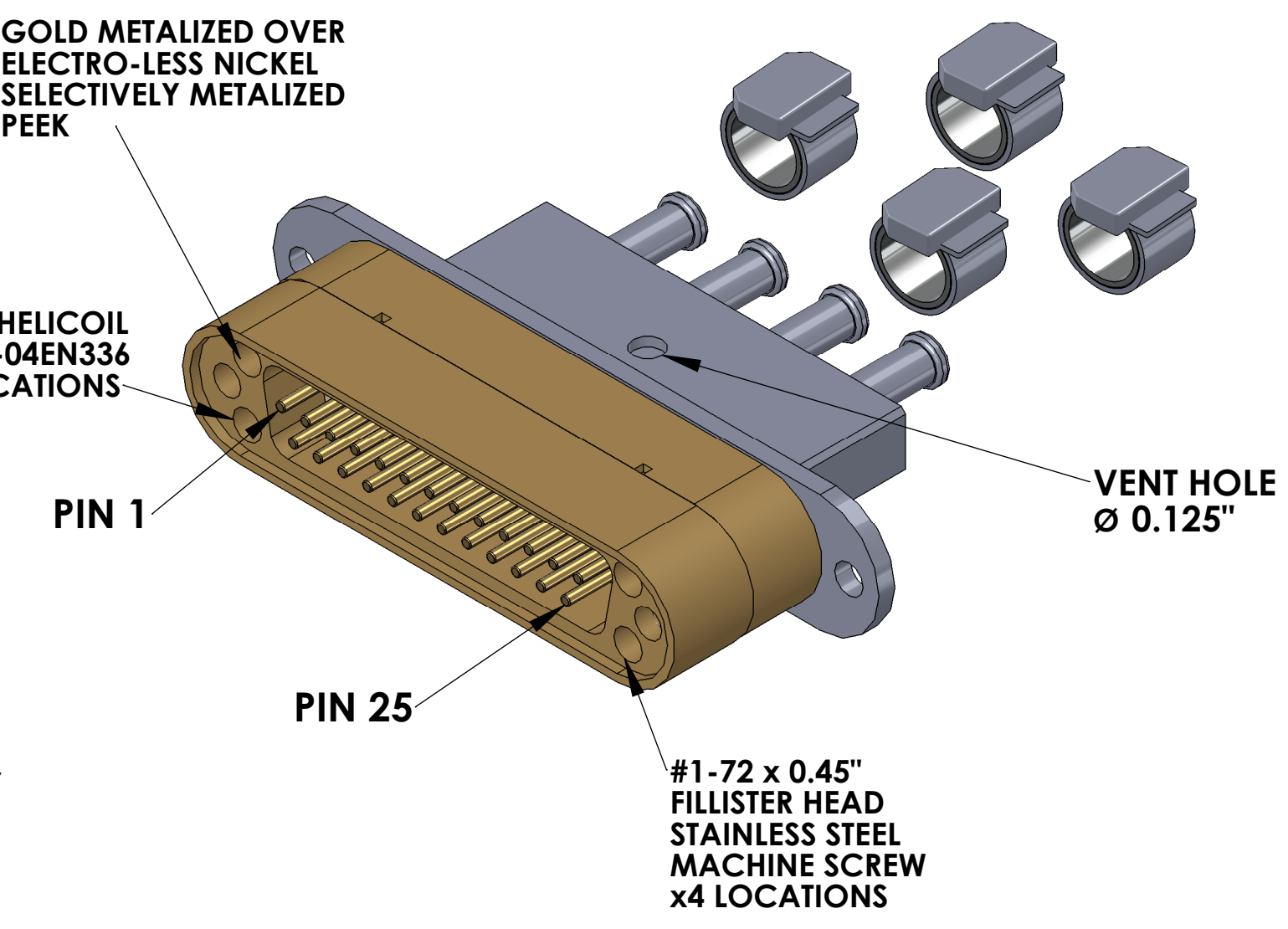

CONNECTOR J1

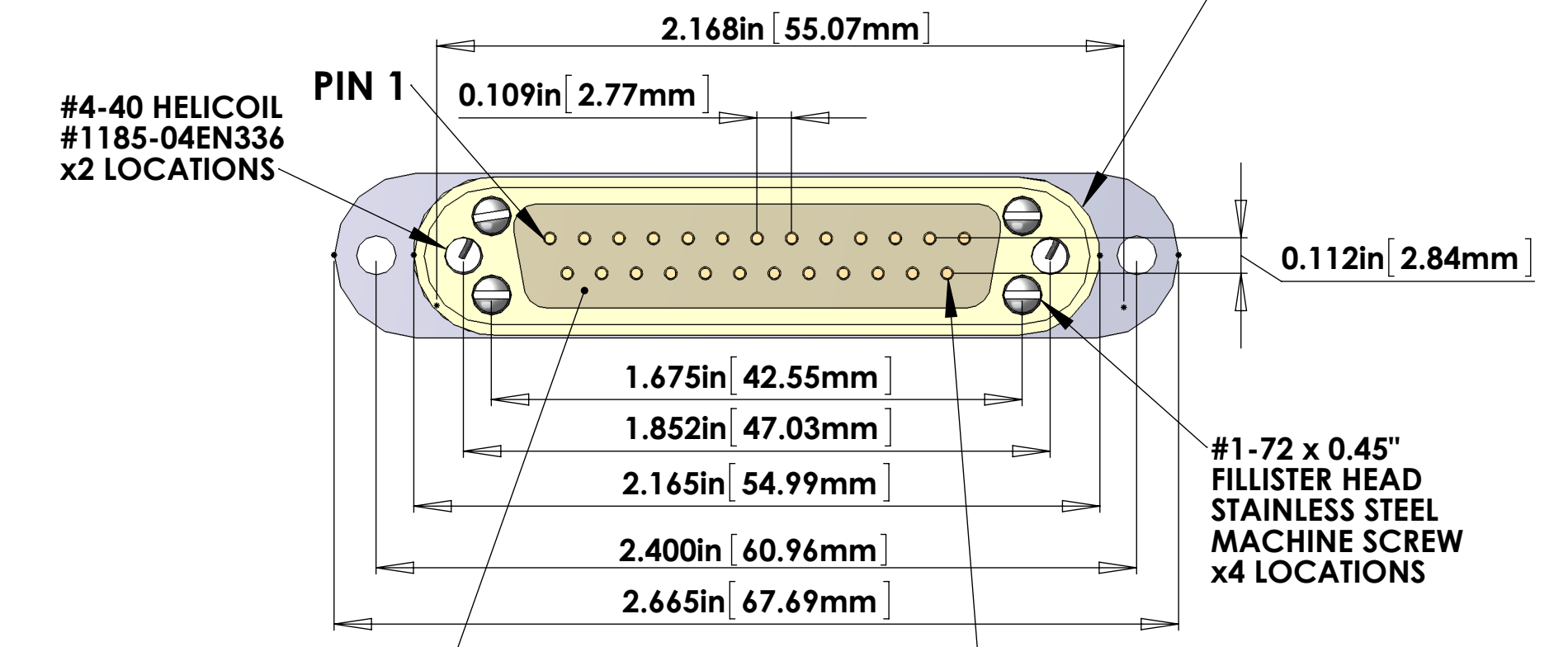
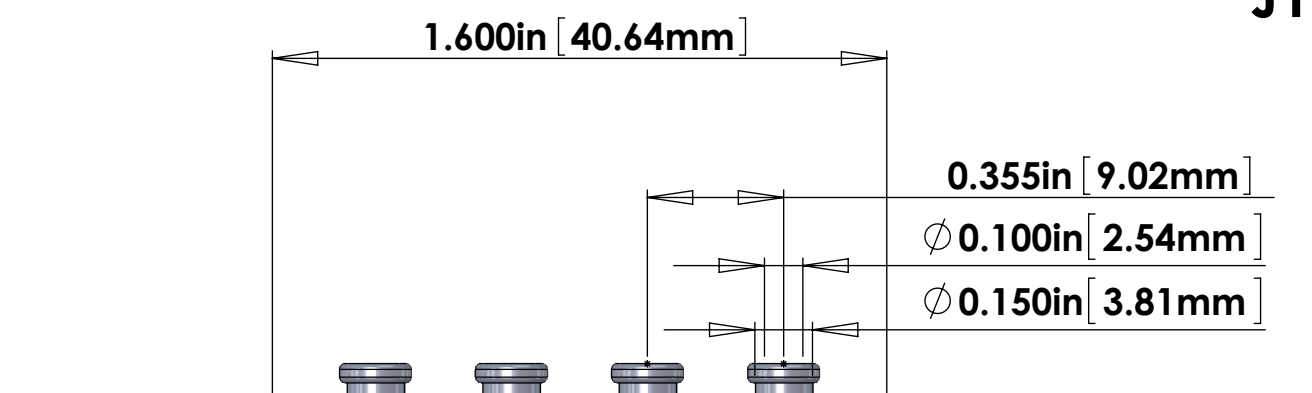

NOT METALIZED BETWEEN THE PINS

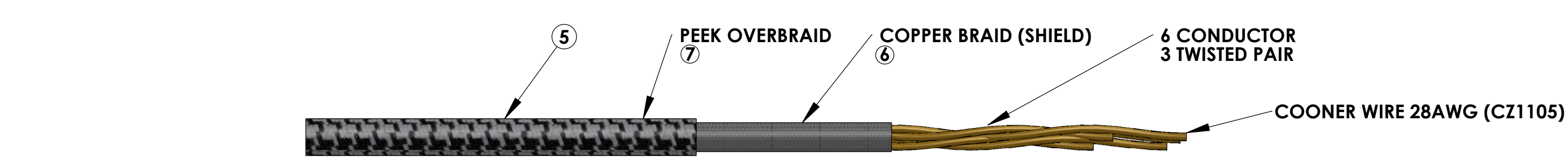

V25N-48 CABLE ASSEMBLY CIRCUIT SUMMARY

V-DB25 M/S1-48-4_u9D F/S

FROM			
CONNECTOR J1 - 25 PIN MALE SUBMINI_D CONNECTOR (METALIZED PEEK)			
PIN	WIRE NAME	LENGTH	TWISTED PAIR
1, SHELL	(CABLE 1) COPPER BRAID		(SHIELD)
14	(CABLE 1) WIRE 14	CABLE 1 48in.*	TP-1
2	(CABLE 1) WIRE 2		
15	(CABLE 1) WIRE 15		
3	(CABLE 1) WIRE 3		
16	(CABLE 1) WIRE 16	CABLE 2 48in.*	TP-2
4	(CABLE 1) WIRE 4		
17	(CABLE 2) WIRE 17		
5	(CABLE 2) WIRE 5		
18	(CABLE 2) WIRE 18	CABLE 3 48in.*	TP-3
6	(CABLE 2) WIRE 6		
19	(CABLE 2) WIRE 19		
7	(CABLE 2) WIRE 7		
1, SHELL	(CABLE 3) COPPER BRAID		(SHIELD)
20	(CABLE 3) WIRE 20	CABLE 4 48in.*	TP-4
8	(CABLE 3) WIRE 8		
21	(CABLE 3) WIRE 21		
9	(CABLE 3) WIRE 9		
22	(CABLE 3) WIRE 22	CABLE 5 48in.*	TP-5
10	(CABLE 3) WIRE 10		
23	(CABLE 4) WIRE 23		
11	(CABLE 4) WIRE 11		
24	(CABLE 4) WIRE 24	CABLE 6 48in.*	TP-6
12	(CABLE 4) WIRE 12		
25	(CABLE 4) WIRE 25		
13	(CABLE 4) WIRE 13		

TEST LIST

FROM	TO
J1	J2
PIN	PIN
J1 - 1, SHELL	J2 - 5 - SHELL
J1 - 14	J2 - 1
J1 - 15	J2 - 6
J1 - 15	J2 - 2
J1 - 3	J2 - 7
J1 - 16	J2 - 4
J1 - 4	J2 - 9

TEST LIST

FROM	TO
J1	J3
PIN	PIN
J1 - 1, SHELL	J3 - 5 - SHELL
J1 - 17	J3 - 1
J1 - 5	J3 - 6
J1 - 18	J3 - 2
J1 - 6	J3 - 7
J1 - 19	J3 - 4
J1 - 7	J3 - 9

TEST LIST

FROM	TO
J1	J4
PIN	PIN
J1 - 1, SHELL	J4 - 5 - SHELL
J1 - 20	J4 - 1
J1 - 8	J4 - 6
J1 - 21	J4 - 2
J1 - 9	J4 - 7
J1 - 22	J4 - 4
J1 - 10	J4 - 9

TEST LIST

FROM	TO
J1	J5
PIN	PIN
J1 - 1, SHELL	J5 - 5 - SHELL
J1 - 23	J5 - 1
J1 - 11	J5 - 6
J1 - 24	J5 - 2
J1 - 12	J5 - 7
J1 - 25	J5 - 4
J1 - 13	J5 - 9

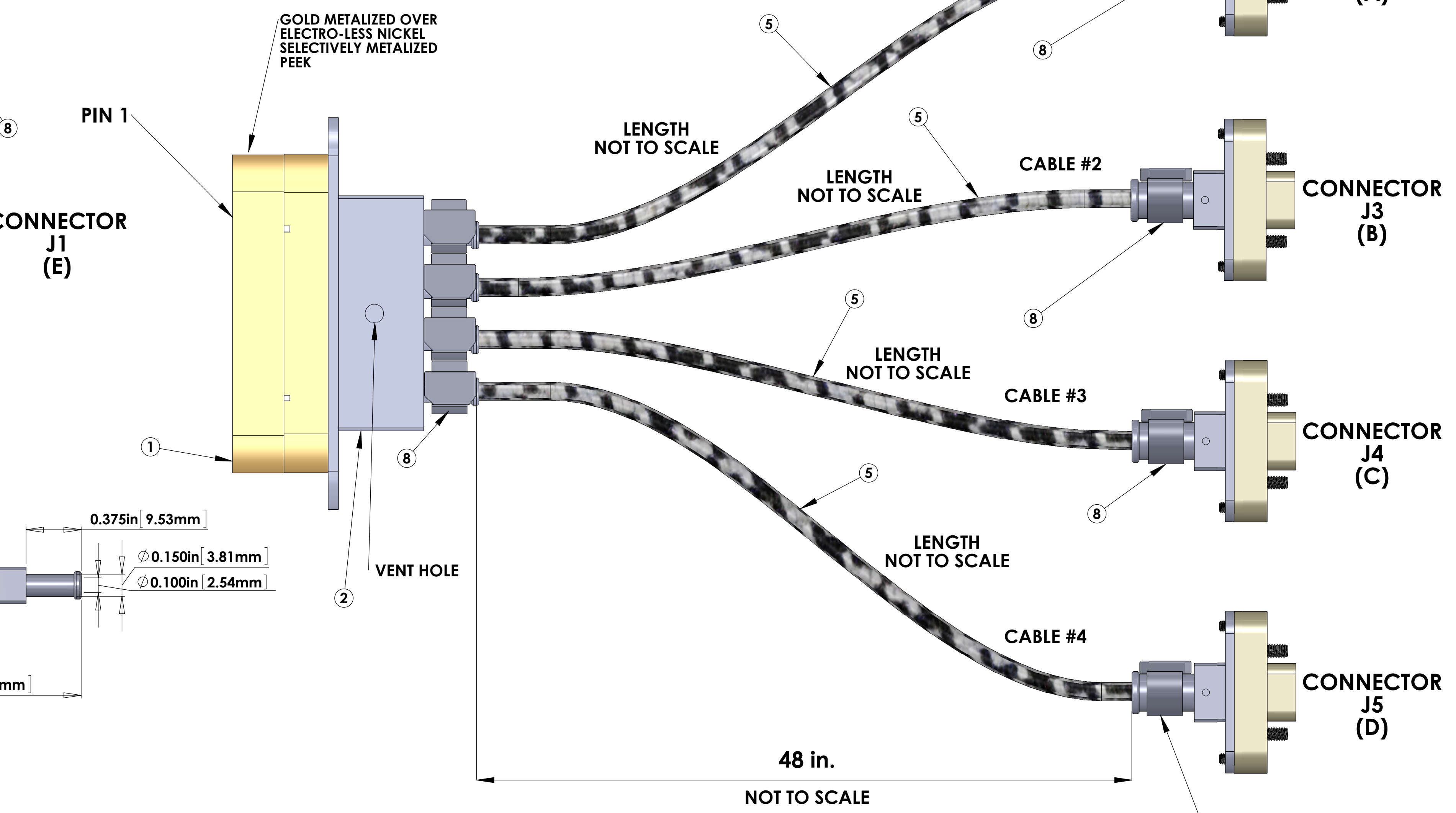

V25N-48 CABLE ASSEMBLY CIRCUIT SUMMARY

TO

CONNECTOR J2 - 9 PIN FEMALE MICRO_D CONNECTOR (PEEK)		
PIN	WIRE NAME	SIGNAL
SHELL	(CABLE 1) COPPER BRAID	SHIELD
1	(CABLE 1) WIRE 14	PHOTO DIODE CATHODE - (UL PD K)
2	(CABLE 1) WIRE 2	PHOTO DIODE ANODE + (UL PD A)
6	(CABLE 1) WIRE 15	LED ANODE + (UL LED A)
7	(CABLE 1) WIRE 3	LED CATHODE - (UL LED K)
4	(CABLE 1) WIRE 16	UL FN
9	(CABLE 1) WIRE 4	UL ST
3, 5, 8	NOT CONNECTED	NOT CONNECTED

V25N-48 CABLE ASSEMBLY CIRCUIT SUMMARY

TO

CONNECTOR J3 - 9 PIN FEMALE MICRO_D CONNECTOR (PEEK)		
PIN	WIRE NAME	SIGNAL
SHELL	(CABLE 2) COPPER BRAID	SHIELD
1	(CABLE 2) WIRE 17	PHOTO DIODE CATHODE - (LL PD K)
6	(CABLE 2) WIRE 8	PHOTO DIODE ANODE + (LL PD A)
2	(CABLE 2) WIRE 18	LED ANODE + (LL LED A)
7	(CABLE 2) WIRE 6	LED CATHODE - (LL LED K)
4	(CABLE 2) WIRE 19	LL FN
9	(CABLE 2) WIRE 7	LL ST
3, 5, 8	NOT CONNECTED	NOT CONNECTED

V25N-48 CABLE ASSEMBLY CIRCUIT SUMMARY

TO

CONNECTOR J4 - 9 PIN FEMALE MICRO_D CONNECTOR (PEEK)		
PIN	WIRE NAME	SIGNAL
SHELL	(CABLE 3) COPPER BRAID	SHIELD
1	(CABLE 3) WIRE 20	PHOTO DIODE CATHODE - (UR PD K)
6	(CABLE 3) WIRE 8	PHOTO DIODE ANODE + (UR PD A)
2	(CABLE 3) WIRE 21	LED ANODE + (UR LED A)
7	(CABLE 3) WIRE 9	LED CATHODE - (UR LED K)
4	(CABLE 3) WIRE 22	UR FN
9	(CABLE 3) WIRE 10	UR ST
3, 5, 8	NOT CONNECTED	NOT CONNECTED

V25N-48 CABLE ASSEMBLY CIRCUIT SUMMARY

TO

CONNECTOR J5 - 9 PIN FEMALE MICRO_D CONNECTOR (PEEK)		
PIN	WIRE NAME	SIGNAL
SHELL	(CABLE 4) COPPER BRAID	SHIELD
1	(CABLE 4) WIRE 23	PHOTO DIODE CATHODE - (LR PD K)
6	(CABLE 4) WIRE 11	PHOTO DIODE ANODE + (LR PD A)
2	(CABLE 4) WIRE 24	LED ANODE + (LR LED A)
7	(CABLE 4) WIRE 12	LED CATHODE - (LR LED K)
4	(CABLE 4) WIRE 25	LR FN
9	(CABLE 4) WIRE 13	LR ST
3, 5, 8	NOT CONNECTED	NOT CONNECTED

BILL OF MATERIALS

ITEM NO.	PART NUMBER	DESCRIPTION	QTY.	LENGTH
1	TICOR #TS0125-3 (OR EQUIVALENT)	DB25 MALE CONNECTOR (J1) FOR UHV (GOLD METALIZED PEEK)	1	
2	TICOR #TS0094 (OR EQUIVALENT) WITH FLYING LEADS	DB25 CONNECTOR BACKSHELL FOR UHV (STAINLESS)	1	
3	TICOR #TS0094 (OR EQUIVALENT) WITH FLYING LEADS	u9D SOCKET (FEMALE) CONNECTOR (J2,J3,J4,J5) FOR UHV (PEEK)	4	
4	TICOR #TS0094 (OR EQUIVALENT) WITH FLYING LEADS	u9D CONNECTOR BACKSHELL FOR UHV (STAINLESS)	4	
5	CABLE INCLUDING COONER WIRE # CZ1105	6 COND. (3 TWISTED PAIR) CABLE (AND COPPER BRAID (SHIELD) 6, AND PEEK OVERBRAID) 7.	4	48in.*
6	CONTINENTAL PART #24x3x40BC	COPPER BRAID - CONTINENTAL CORDAGE PART #24x3x40BC	4	48in.*
7	PART #6759	PEEK BRAID - PART #6759 MANUFACTURED WITH ZEUS 0.016" BLACK PEEK DRAWN MONOFILAMENT	4	48in.*
8	GLENAIR # 600-052 or BAND-IT # A10086	GLENAIR # 600-052 STANDARD BRAID CLAMP or BAND-IT PART # A10086 (0.240" WIDE) ("BAG OF 100" # A10089)	8	
9	HELICOIL #1185-04EN336	#4-40 Nitronic 60 HELICOIL 0.336" LENGTH	2	

* NOTE: THE OVERALL LENGTH IS MEASURED FROM BAND CLAMP ("CABLE SIDE" EDGE) (25 PIN) TO BAND CLAMP ("CABLE SIDE" EDGE) (9 PIN) OF THE CABLE. USE WHATEVER LENGTH IS NECESSARY FOR THE INTERNAL WIRING OF THE CONNECTORS AND STRIP LENGTH TO ACHIEVE THE CORRECT OVERALL LENGTH.

ELECTRICAL NOTES: (UNLESS OTHERWISE SPECIFIED)

- MATERIAL: a. J1 CONNECTOR SHELL - GOLD OVER ELECTRO-LESS NICKEL SELECTIVELY METALIZED PEEK VICTREX 450GL30. b. J2, J3, J4, J5 CONNECTOR SHELL - PEEK VICTREX 450GL30. c. BACKSHELL - STAINLESS STEEL WITH 4 PORTS AND VENT HOLE. d. CONTACTS - BERYLLIUM COPPER ALLOY C17300 0.000050 MIN. GOLD OVER NICKEL. e. HARDWARE: STAINLESS STEEL, PASSIVATED. f. PEEK BRAID - PEEK VICTREX GRADE TDS-450CA30 CARBON LOADED.

- CABLE 6 COND. 28 AWG, (65 STRD 46 AWG) WITH PFA INSULATION COONER # CZ1105. 3 TWISTED PAIRS. (4 TO 5 TWISTS PER INCH). OVERALL 40AWG COPPER BRAID 90% COVERAGE. OVERALL PEEK BRAID MIN. 50% COVERAGE. OVERALL CABLE O.D. WILL BE APPROX. 0.240 IN.
- CONNECTORS WILL BE SUPPLIED WITH HARDWARE. LENGTH OF SCREWS SHOULD BE THE PROPER LENGTH FOR MATING.

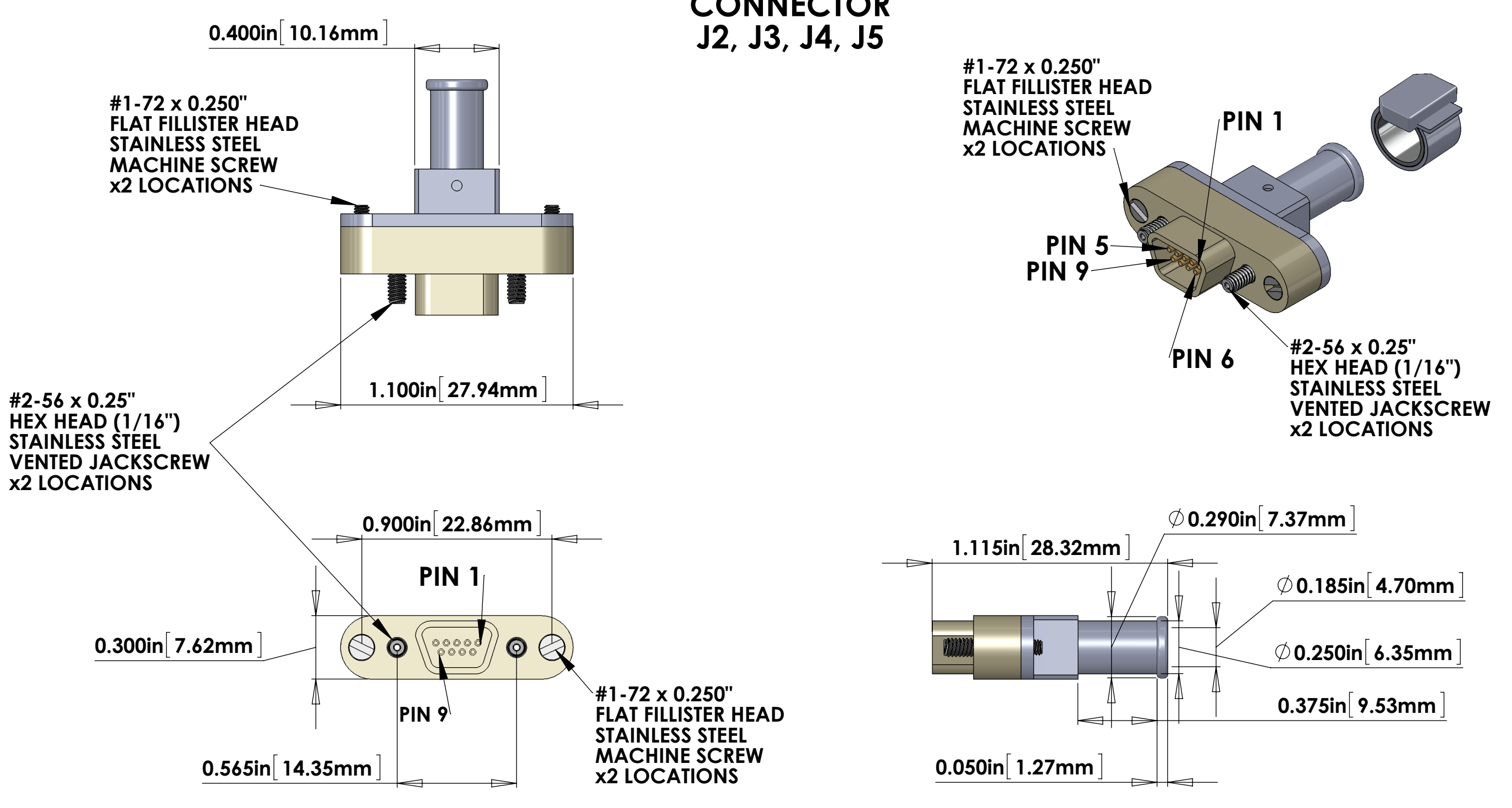

HAM AUX CABLE

SEISMIC TABLE TO HAM AUX OSEMS

V-DB25 M/S1-48-4_u9D F/S

STANDARD USE FOR THIS CABLE

SUBSYSTEM	AIR/VAC	STANDARD USE
ISC	IN-VAC	HAM AUX OSEMS

DIMENSIONS ARE IN		NOTES AND TOLERANCES: (UNLESS OTHERWISE SPECIFIED)		CALIFORNIA INSTITUTE OF TECHNOLOGY MASSACHUSETTS INSTITUTE OF TECHNOLOGY		PART NAME CUSTOM CABLE SPECIFICATION V25N-48		
TOLERANCES: .XX ± .XXX ±		1. INTERPRET DRAWING PER ASME Y14.5-1994. 2. REMOVE ALL SHARP EDGES. .005-.015. FOR MACHINED PARTS. ROUND ALL EDGES APPROXIMATELY R.02 FOR SHEET METAL PARTS. 3. DO NOT SCALE FROM DRAWING. 4. ALL MACHINING FLUIDS MUST BE FULLY SYNTHETIC, FULLY WATER SOLUBLE AND FREE OF SULFUR, SILICONE, AND CHLORINE.		SYSTEM		DESIGNER: J. HEFFNER DRAFTER: E. BROWN CHECKER: APPROVAL:		SIZE DWG. NO. E D1000239
ANGULAR ± °		MATERIAL		FINISH		NEXT ASSY		
		FINISH		SCALE: 2:1		PROJECTION:		
		FINISH		SCALE: 2:1		PROJECTION:		