

REV.	DATE	DCN #	DRAWING TREE #
00		Initial Release	

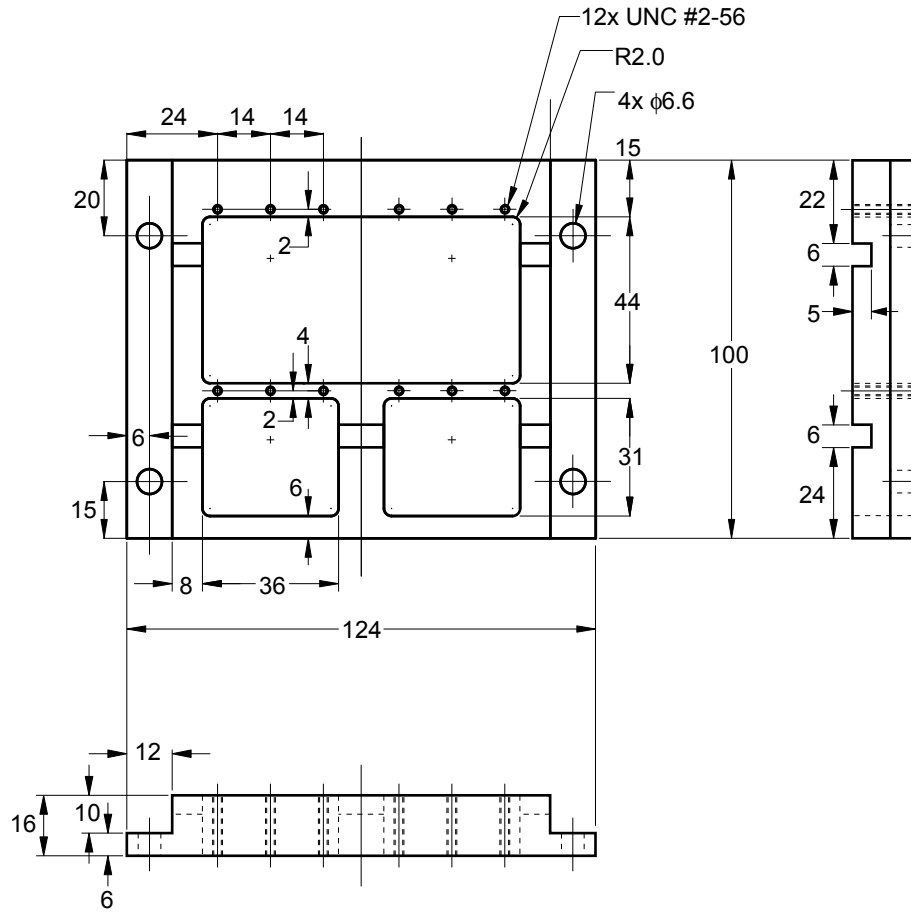

NOTES: (UNLESS OTHERWISE SPECIFIED)		CALIFORNIA INSTITUTE OF TECHNOLOGY MASSACHUSETTS INSTITUTE OF TECHNOLOGY	
1. DO NOT SCALE FROM DRAWING 2. REMOVE ALL SHARP EDGES, R.02 MAX. 3. ALL MACHINING FLUIDS SHALL BE WATER SOLUBLE AND FREE OF SULFUR, CHLORINE AND SILICONE, SUCH AS CINCINNATI MILACRON'S CIMTECH 410 (STAINLESS STEEL)		DIMENSIONS IN MILLIMETERS TOLERANCES: .X ± 0.2 .XX ± 0.05 ANGULAR ± 0.5 °	
④ SCRIBE, ENGRAVE OR STAMP DRAWING PART NUMBER, REVISION ON NOTED SURFACE OF PART AND THEN A THREE DIGIT SERIAL NUMBER. SERIAL NUMBERS START AT 001 FOR THE FIRST PART AND PROCEED CONSECUTIVELY. USE 2 mm HIGH CHARACTERS. A VIBRATORY TOOL MAY BE USED. EXAMPLE: D020188-00 SN 001		MATERIAL <b>6061 Alloy</b>	
		FINISH <b>32 μ inch</b>	
		NEXT ASSY <b>Tip-Tilt Structure</b>	
		PARTNAME <b>Passive Tip-Tilt ECD Backplane</b>	
		SYSTEM <b>LIGO 40M</b>	
		SUBSYSTEM <b>40M</b>	
		DRAWN Koji Arai 15 Feb 10 CHECKED APPROVED	
		SIZE DWG. NO. <b>A D1000383</b>	
		REV. <b>v1</b>	
		SCALE: 1:2 PROJECTION:  SHEET OF 1	