

REV.	DATE	DCN #	DRAWING TREE #
A	6 NOV 06	E060262	E060243
B	1 APR 07	E060262	E060243
C	12 DEC 07	E060262	E060243

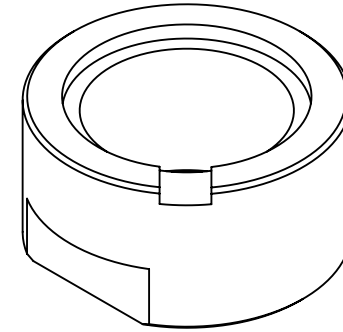
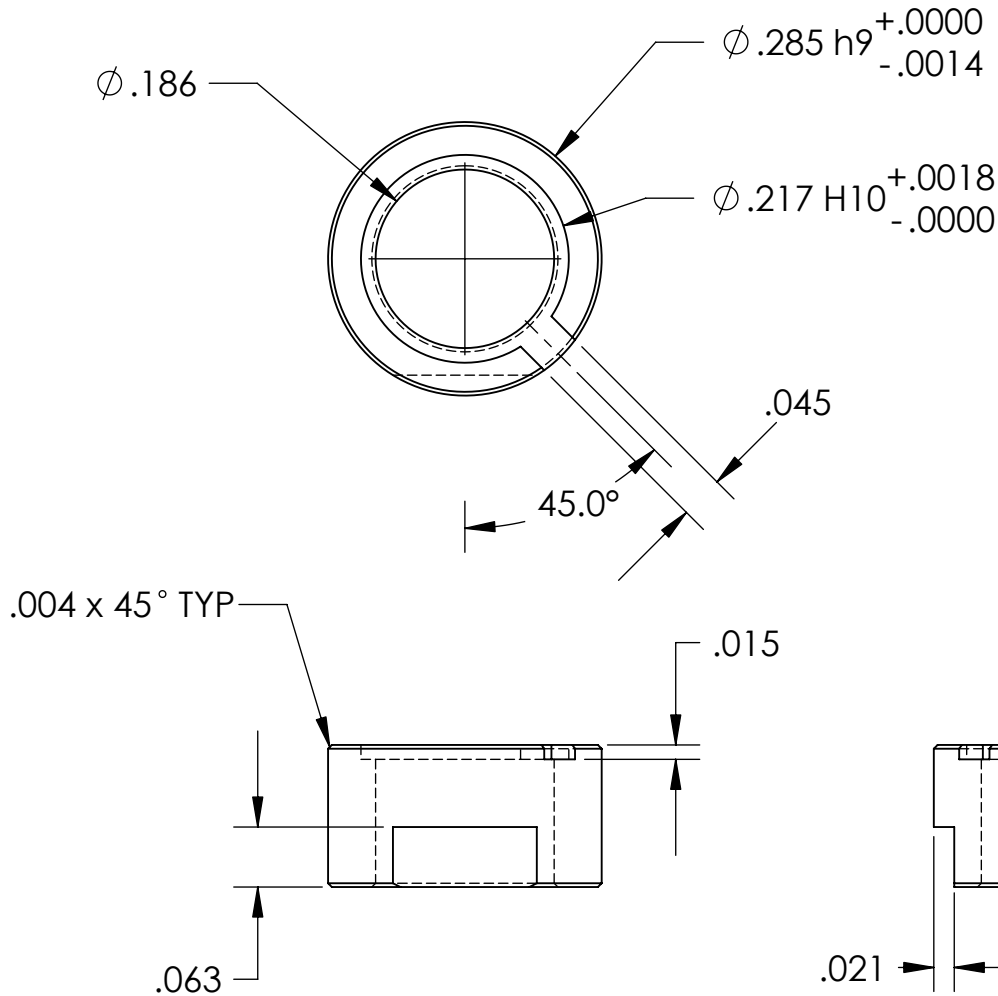

NOTES: (UNLESS OTHERWISE SPECIFIED)

1. DO NOT SCALE FROM DRAWING
2. REMOVE ALL SHARP EDGES, R.02 MAX.
3. ALL MACHINING FLUIDS SHALL BE WATER SOLUBLE AND FREE OF SULFUR, CHLORINE AND SILICONE, SUCH AS CINCINNATI MILACRON'S CIMTECH 410 (STAINLESS STEEL)
4. HOLE & SHAFT FITS ARE ALSO GIVEN ACCORDING TO BS4500:1969

DIMENSIONS ARE IN INCHES [mm]

TOLERANCES:

.XX ± 0.01

.XXX ± 0.005

ANGULAR $\pm 0.5^\circ$

MATERIAL

Macor

FINISH

32 μ inch

	NAME	DATE
DRAWN	S. Bookes	26 JUN 06
CHECKED	S. Aston	22 AUG 06
APPROVED	A. Vecchio	31 OCT 06



CALIFORNIA INSTITUTE OF TECHNOLOGY
 MASSACHUSETTS INSTITUTE OF TECHNOLOGY
 IGR, GLASGOW UNIVERSITY GEO 600 GROUP
 UNIVERSITY OF BIRMINGHAM

SYSTEM

ADVANCED LIGO

SUB-SYSTEM

SUS

NEXT ASSY

D060217 BOSEM PD Assembly

PART NAME

PD Sleeve

SIZE DWG. NO.

A D060117

REV.

C

SCALE: 5:1

PROJECTION:



SHEET 1 OF 1