

NOTES CONTINUED:

⑤ SCRIBE, ENGRAVE, OR MECHANICALLY STAMP (NO INKS OR DYES) DRAWING PART NUMBER AND REVISION ON NOTED SURFACE FOLLOWED ON THE NEXT LINE BY A THREE DIGIT SERIAL NUMBER. SERIAL NUMBERS START AT 001 FOR THE FIRST ARTICLE AND PROCEED CONSECUTIVELY. USE .07" HIGH CHARACTERS. EXAMPLE: DXXXXXX-VY, S/N 001. A VIBRATORY TOOL MAY BE USED.

REV.	DATE	DCN #	DRAWING TREE #
-	-	-	-
-	-	-	-
-	-	-	-

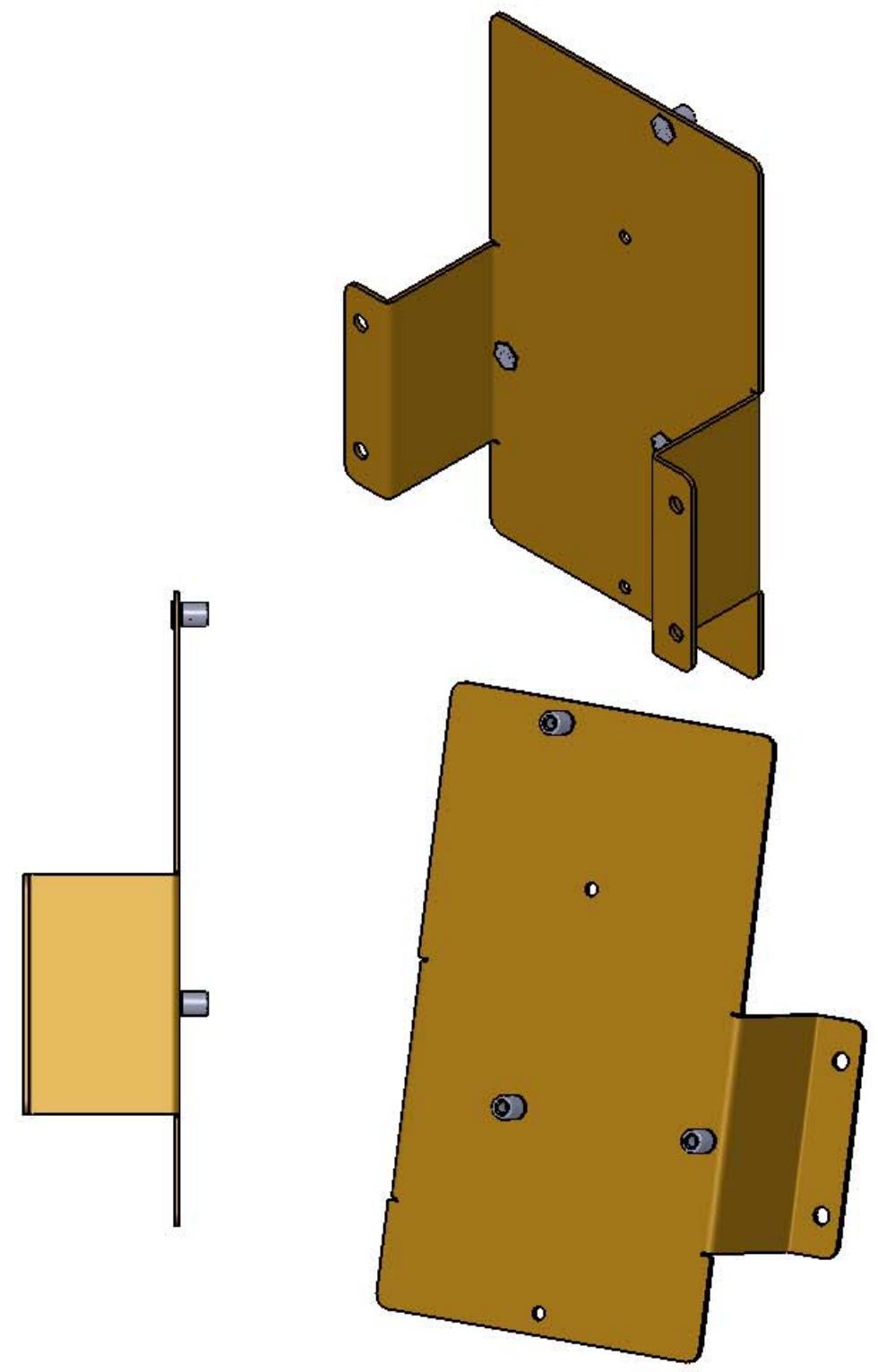
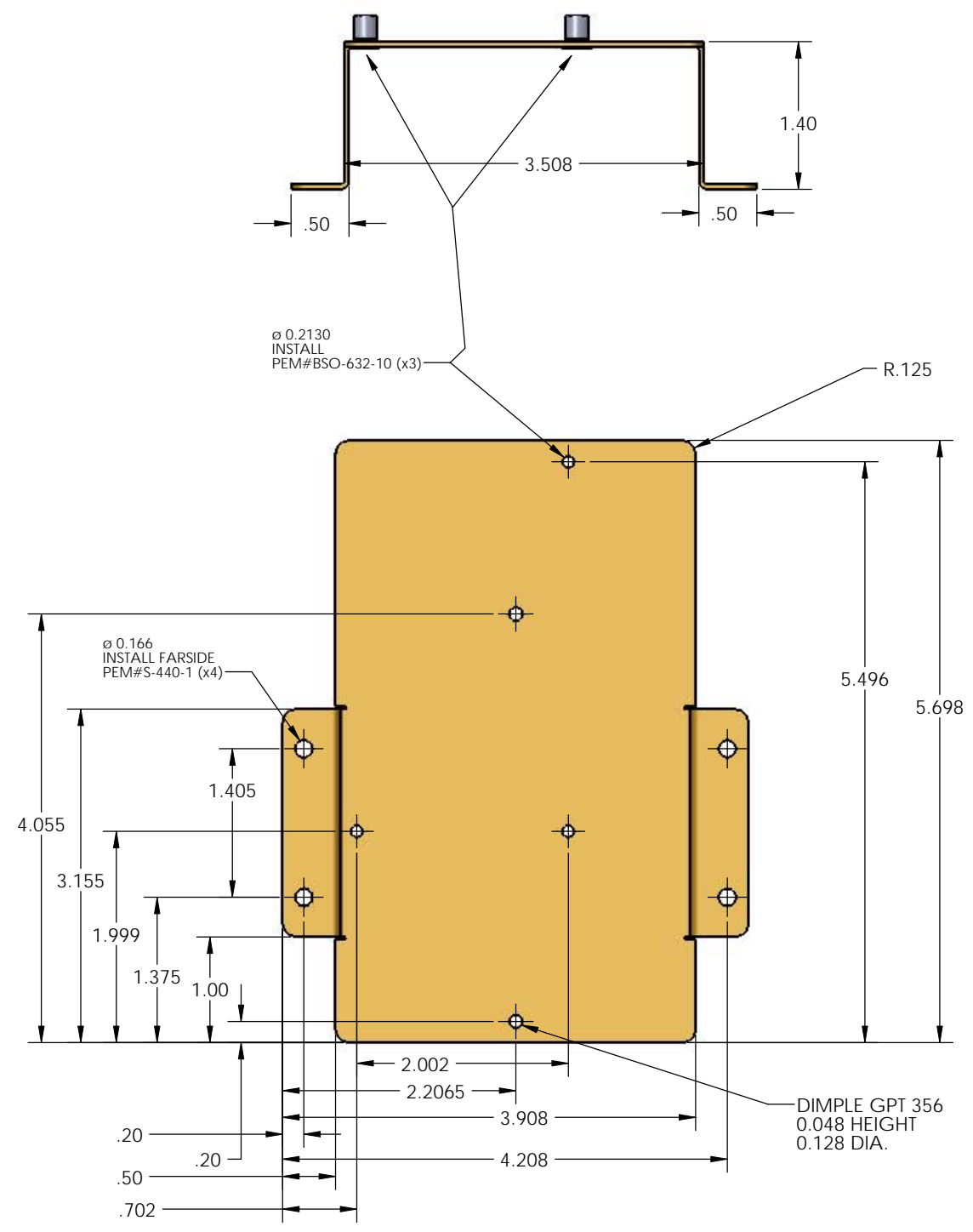

NOTES AND TOLERANCES: (UNLESS OTHERWISE SPECIFIED)

1. INTERPRET DRAWING PER ASME Y14.5-1994.
2. REMOVE ALL SHARP EDGES, R.02 MIN.
3. DO NOT SCALE FROM DRAWING.
4. ALL MACHINING FLUIDS MUST BE FULLY SYNTHETIC, FULLY WATER SOLUBLE AND FREE OF SULFUR, SILICONE, AND CHLORINE.

MATERIAL: Material: 18 GA C.R.S. (0.048) FINISH: μinch

**LIGO** CALIFORNIA INSTITUTE OF TECHNOLOGY MASSACHUSETTS INSTITUTE OF TECHNOLOGY

PART NAME: I/O EXPANSION CHASSIS - SPOTWELD PANEL D

DIMENSIONS ARE IN TOLERANCES: .XX ± .XXX ± ANGULAR ± °

SYSTEM	SUB-SYSTEM: DAQ	DESIGNER	SIZE: c	DWG. NO.: D1001711_v1	REV.
NEXT ASSY		DRAFTER: E.BROWN	JUL/08/2010		
		CHECKER	SCALE: 1:1	PROJECTION:	SHEET 1 OF 1
		APPROVAL			