

PROPRIETARY AND CONFIDENTIAL  
 THE INFORMATION CONTAINED IN THIS  
 DRAWING IS THE SOLE PROPERTY OF  
 GNB CORPORATION. ANY  
 REPRODUCTION IN PART OR AS A WHOLE  
 WITHOUT THE WRITTEN PERMISSION OF  
 GNB CORPORATION IS PROHIBITED.

REVISIONS				
ZONE	REV.	DESCRIPTION	DATE	APPROVED
	A	REMOVED WELD PREP	8/18/2010	MKM2
	B	RELEASED TO PRODUCTION	8/23/2010	MKM2

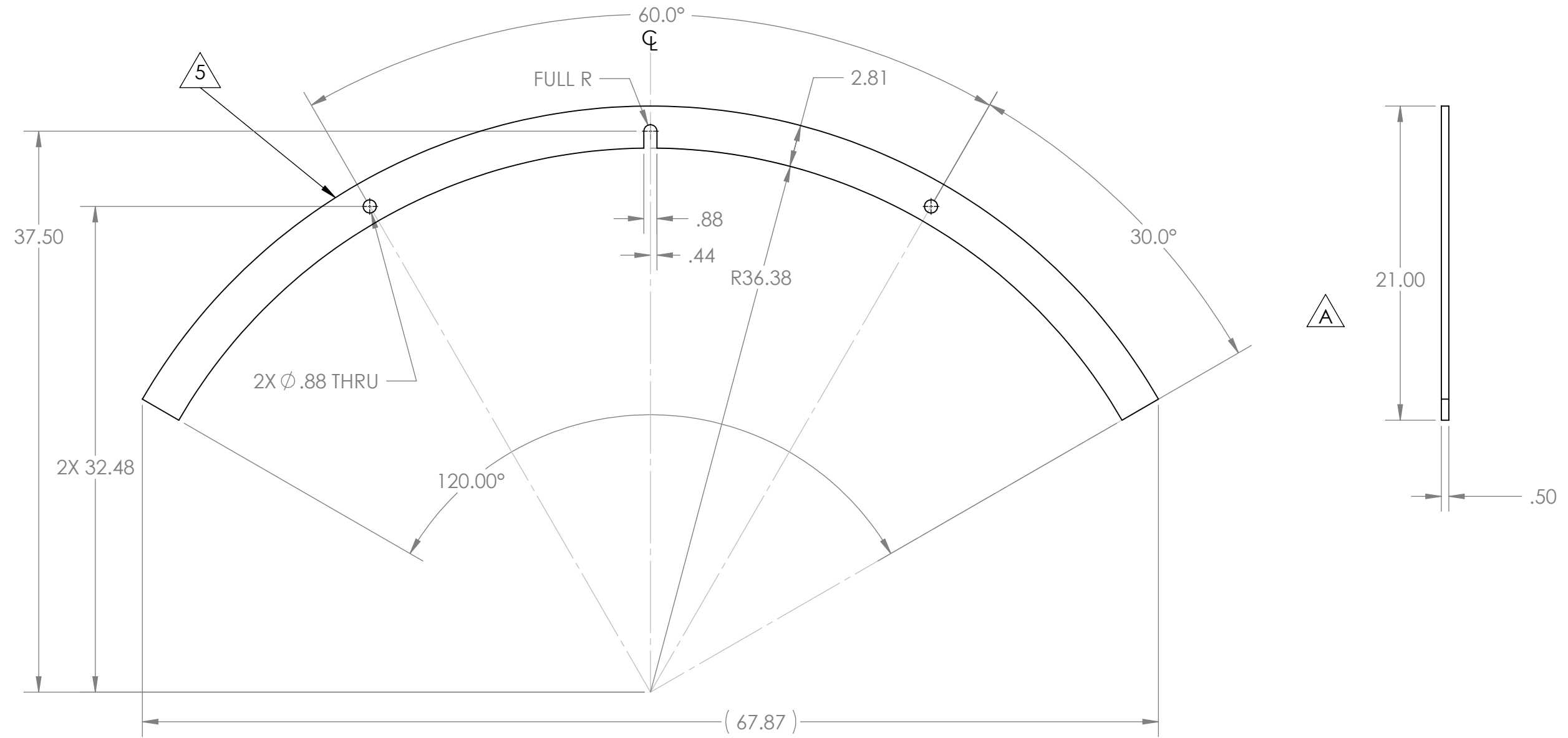

- NOTES:**
- THE FOLLOWING ARE NOT ALLOWED: GRINDING, HONING, LAPPING, POLISHING, BUFFING, SANDING, BLASTING.
  - NO HYDROCARBONS ALLOWED IN THE COOLANT. COOLANT LIMITS AS FOLLOWS
    - WATER LEACHABLE CHLORIDES: 100PPM
    - TOTAL HALOGENS (INCLUDING CHLORIDES): 1000PPM
    - TOTAL SULFUR: 1000PPM
  - DO NOT ALLOW PART TO BE CONTAMINATED BY CARBON STEEL OR IRON CONTACT.
  - MACHINING TO BE IN LINE WITH LIGO SPECIFICATION E0900406, LATEST REVISION.
  - USING A VIBRATORY TOOL WITH A TIP WITH A MINIMUM RADIUS OF .005", ENGRAVE THE FOLLOWING ON THE INDICATED SURFACE:
    - HEAT NUMBER
    - LOT NUMBER
    - PART NUMBER
  - A 2"X12" COUPON OF MATERIAL FROM THE SAME LOT OF MATERIAL MUST BE PROVIDED WITH EACH PIECE.

DESCRIPTION PLT, .50 THK, 21.0 WD, 67.88 LG  
 MATERIAL: AISI 304/AISI 304L DUAL CERT PER SA240  
 WEIGHT: 31.80#

APPROVALS	DATE
DRAFTER MKM2	6/14/10
CHECKER RW	6/14/10
ENGINEER MKM2	6/14/10

UNLESS OTHERWISE SPECIFIED:  
 DIMENSIONS ARE IN INCHES  
 TOLERANCES: FINISH 125  
 ANGULAR: ± 0°30'  
 .XX ± .03  
 .XXX ± .005  
 UNSPECIFIED FILLETS: R.015  
 BREAK EDGES .010x45°  
 REMOVE ALL BURRS

FINISH 125

///, □, ⊥ WITHIN .03

THIRD ANGLE PROJECTION

**GNB CORPORATION**  
 SCIENTIFIC AND INDUSTRIAL EQUIPMENT  
 3200 DWIGHT RD. SUITE 100  
 ELK GROVE, CA, 95758  
 916-395-3003 FAX: 916-395-3363  
 www.gnbvalves.com

TITLE: **STIFFENER, ADAPTER A-18**

DO NOT SCALE DRAWING

DWG. NO. **B** 114322-00S  
 SCALE: 1:8 SHEET 1 OF 1

REV **B**