

PROPRIETARY AND CONFIDENTIAL
 THE INFORMATION CONTAINED IN THIS
 DRAWING IS THE SOLE PROPERTY OF
 GNB CORPORATION. ANY
 REPRODUCTION IN PART OR AS A WHOLE
 WITHOUT THE WRITTEN PERMISSION OF
 GNB CORPORATION IS PROHIBITED.

REVISIONS				
ZONE	REV.	DESCRIPTION	DATE	APPROVED
	A	REMOVED CHAMFERS FOR CHANGED WELD TYPE	8/18/2010	MKM2
	B	RELEASED TO PRODUCTION	8/23/2010	MKM2
	C	REVISED WELD PREP	8/25/2010	MKM2

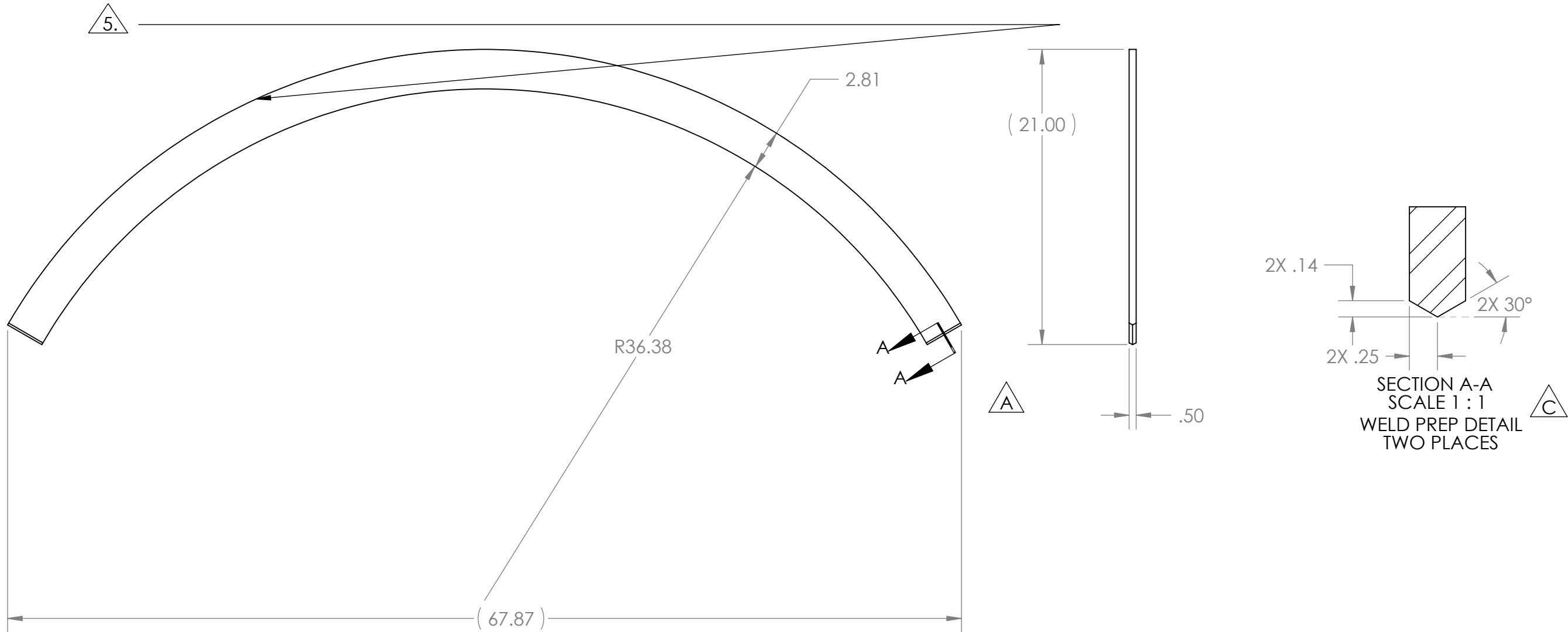

- NOTES:
- THE FOLLOWING ARE NOT ALLOWED: GRINDING, HONING, LAPPING, POLISHING, BUFFING, SANDING, BLASTING.
 - NO HYDROCARBONS ALLOWED IN THE COOLANT. COOLANT LIMITS AS FOLLOWS
 - WATER LEACHABLE CHLORIDES: 100PPM
 - TOTAL HALOGENS (INCLUDING CHLORIDES): 1000PPM
 - TOTAL SULFUR: 1000PPM
 - DO NOT ALLOW PART TO BE CONTAMINATED BY CARBON STEEL OR IRON CONTACT.
 - MACHINING TO BE IN LINE WITH LIGO SPECIFICATION E0900406, LATEST REVISION.

5. USING A VIBRATORY TOOL WITH A TIP WITH A MINIMUM RADIUS OF .005", ENGRAVE THE FOLLOWING ON THE INDICATED SURFACE:
- HEAT NUMBER
 - LOT NUMBER
 - PART NUMBER
6. A 2"X12" COUPON OF MATERIAL FROM THE SAME LOT OF MATERIAL MUST BE PROVIDED WITH EACH PIECE.

DESCRIPTION PLT, .50 THK, 21.0 WD, 67.88 LG
 MATERIAL: AISI 304/AISI 304L DUAL CERT PER SA240

UNLESS OTHERWISE SPECIFIED:
 DIMENSIONS ARE IN INCHES
 TOLERANCES: FINISH
 ANGULAR: ± 0°30' 125
 .XX ± .03
 .XXX ± .005
 UNSPECIFIED FILLETS: R.015
 BREAK EDGES .010x45°
 REMOVE ALL BURRS

//, □, ⊥ WITHIN .03

THIRD ANGLE PROJECTION



WEIGHT: 32.10#

APPROVALS	DATE
DRAFTER MKM2	7/1/10
CHECKER RW	7/9/10
ENGINEER MKM2	7/1/10

GNB CORPORATION
 SCIENTIFIC AND INDUSTRIAL EQUIPMENT
 3200 DWIGHT RD. SUITE 100
 ELK GROVE, CA, 95758
 916-395-3003 FAX: 916-395-3363
 www.gnbvalves.com

TITLE: STIFFENER, ADAPTER A-18

DO NOT SCALE
 DRAWING

B DWG. NO. 114322-01S

SCALE: 1:8 SHEET 1 OF 1

REV
 C