

PROPRIETARY AND CONFIDENTIAL  
 THE INFORMATION CONTAINED IN THIS  
 DRAWING IS THE SOLE PROPERTY OF  
 GNB CORPORATION. ANY  
 REPRODUCTION IN PART OR AS A WHOLE  
 WITHOUT THE WRITTEN PERMISSION OF  
 GNB CORPORATION IS PROHIBITED.

REVISIONS				
ZONE	REV.	DESCRIPTION	DATE	APPROVED
	A	REMOVED CHAMFERS; RELEASED TO PRODUCTION	8/24/2010	MKM2

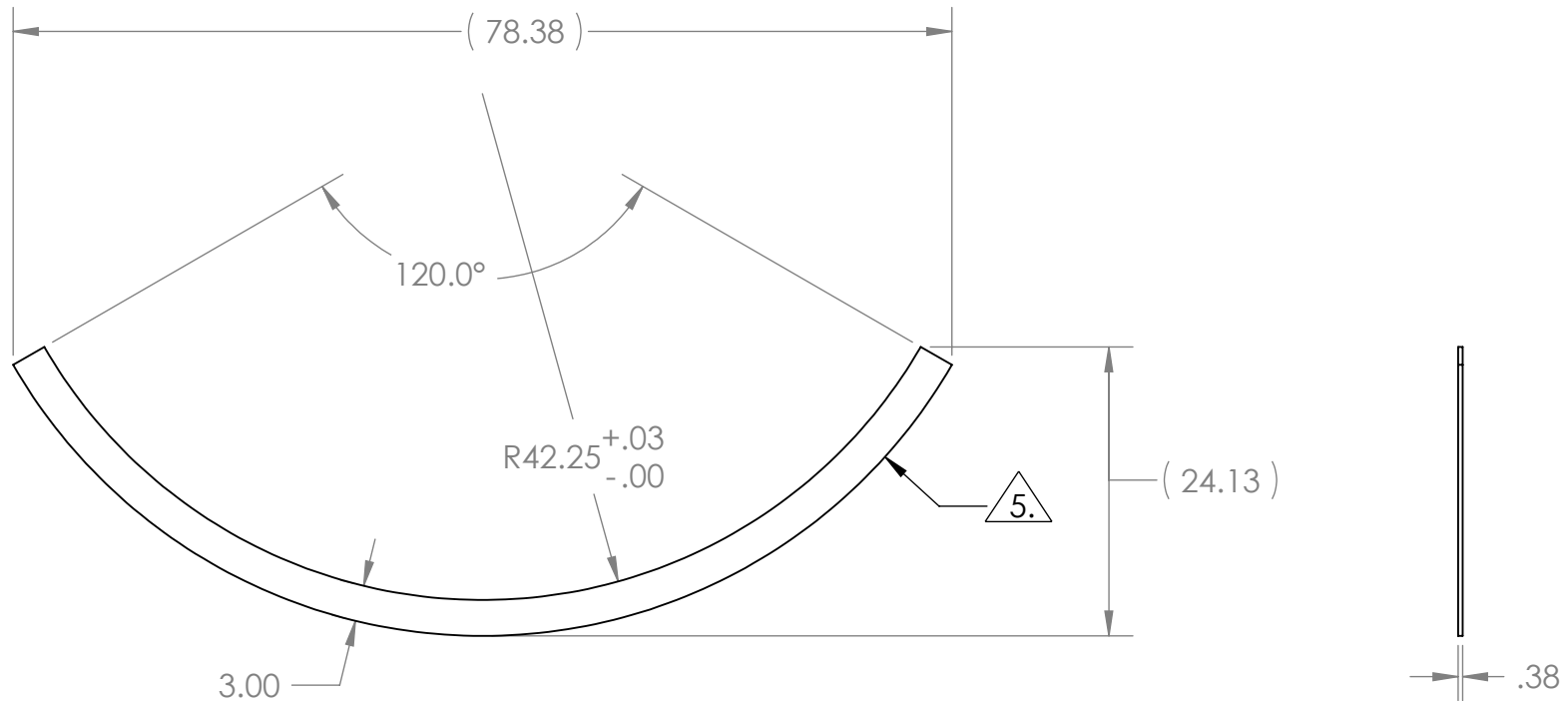

**NOTES:**

1. THE FOLLOWING ARE NOT ALLOWED: GRINDING, HONING, LAPPING, POLISHING, BUFFING, SANDING, BLASTING.
2. NO HYDROCARBONS ALLOWED IN THE COOLANT. COOLANT LIMITS AS FOLLOWS
  - a. WATER LEACHABLE CHLORIDES: 100PPM
  - b. TOTAL HALOGENS (INCLUDING CHLORIDES): 1000PPM
  - c. TOTAL SULFUR: 1000PPM
3. DO NOT ALLOW PART TO BE CONTAMINATED BY CARBON STEEL OR IRON CONTACT.
4. MACHINING TO BE IN LINE WITH LIGO SPECIFICATION E0900406, LATEST REVISION.

5. USING A VIBRATORY TOOL WITH A TIP WITH A MINIMUM RADIUS OF .005", ENGRAVE THE FOLLOWING ON THE INDICATED SURFACE:
- a. HEAT NUMBER
  - b. LOT NUMBER
  - c. PART NUMBER

DESCRIPTION: PLT, .38 THK, 24.13 WD, 78.38 LG		<p>SCIENTIFIC AND INDUSTRIAL EQUIPMENT</p> <p>3200 DWIGHT RD, SUITE 100        ELK GROVE, CA 95758        916-395-3003 FAX: 916-395-3363        WWW.GNBVALVES.COM</p>															
MATERIAL: AISI 304/AISI 304L DUAL CERT PER SA240																	
UNLESS OTHERWISE SPECIFIED:	WEIGHT: 29.79 #	<table border="1"> <thead> <tr> <th colspan="3">APPROVALS</th> </tr> <tr> <th></th> <th>NAME</th> <th>DATE</th> </tr> </thead> <tbody> <tr> <td>DRAFTER</td> <td>MKM2</td> <td>6/14/10</td> </tr> <tr> <td>CHECKER</td> <td>RW</td> <td>6/14/10</td> </tr> <tr> <td>ENGINEER</td> <td>MKM2</td> <td>6/14/10</td> </tr> </tbody> </table>	APPROVALS				NAME	DATE	DRAFTER	MKM2	6/14/10	CHECKER	RW	6/14/10	ENGINEER	MKM2	6/14/10
APPROVALS																	
	NAME		DATE														
DRAFTER	MKM2		6/14/10														
CHECKER	RW	6/14/10															
ENGINEER	MKM2	6/14/10															
DIMENSIONS ARE IN INCHES	FINISH 125																
TOLERANCES:	ANGULAR: ± 0°30'																
.XX ± .03	.XXX ± .005																
UNSPECIFIED FILLETS: R.015	BREAK EDGES .010 x 45°																
REMOVE ALL BURRS	WITHIN .03																
THIRD ANGLE PROJECTION																	
DO NOT SCALE DRAWING		DWG. NO. <b>A</b> 114204-00S SCALE: 1:16															
		TITLE: STIFFENER, 1/3, PLAIN, MC TUBE SHEET 1 OF 1															