

PROPRIETARY AND CONFIDENTIAL
 THE INFORMATION CONTAINED IN THIS DRAWING IS THE SOLE PROPERTY OF GNB CORPORATION. ANY REPRODUCTION IN PART OR AS A WHOLE WITHOUT THE WRITTEN PERMISSION OF GNB CORPORATION IS PROHIBITED.

REVISIONS				
ZONE	REV.	DESCRIPTION	DATE	APPROVED
	A	RELEASED TO PRODUCTION	8/24/2010	MKM2

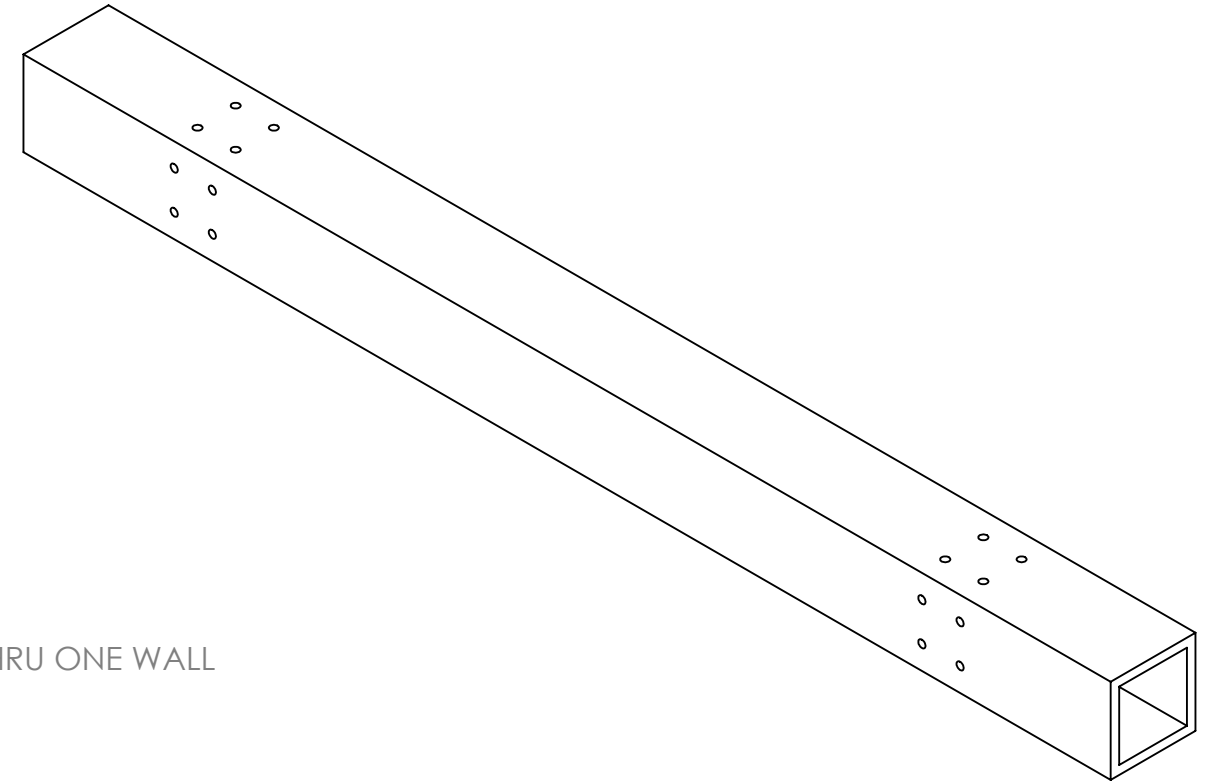

8X 1/2-13 UNC - 2B THRU ONE WALL

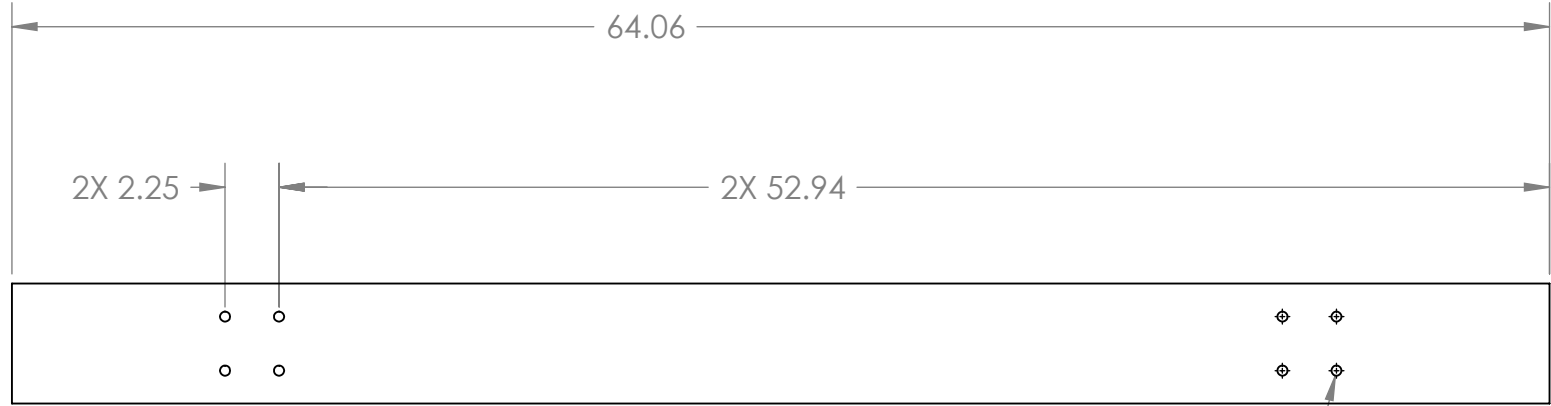
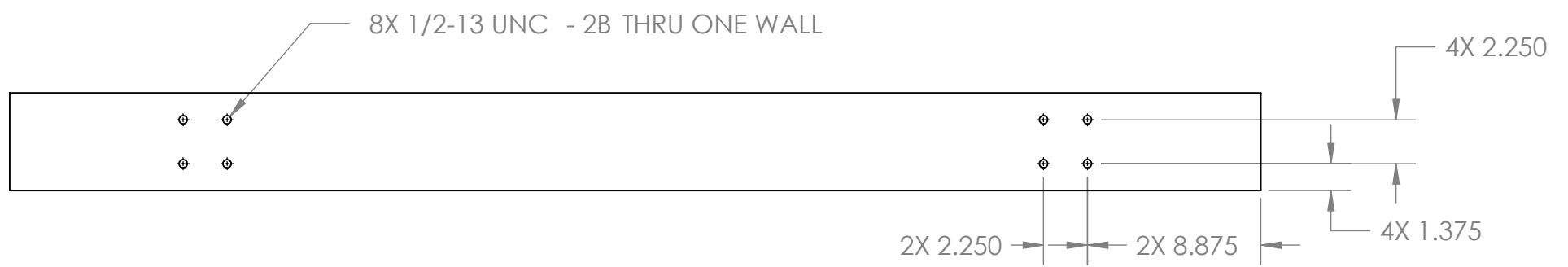

8X 1/2-13 UNC - 2B THRU ONE WALL

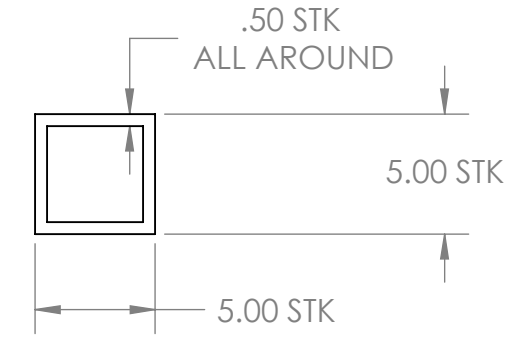

DESCRIPTION TUBE, SQR, 5.00 X 5.00 OD, .50 WALL, 64.06 LG
 MATERIAL: ASTM A36 Steel

UNLESS OTHERWISE SPECIFIED:
 DIMENSIONS ARE IN INCHES
 TOLERANCES: FINISH 125
 ANGULAR: ± 0°30'
 .XX ± .03
 .XXX ± .005
 UNSPECIFIED FILLETS: R.015
 BREAK EDGES .010x45°
 REMOVE ALL BURRS

WEIGHT: 163.19#

APPROVALS	DATE
DRAFTER MKM2	7/7/10
CHECKER RW	7/22/10
ENGINEER MKM2	7/7/10

GNB CORPORATION
 SCIENTIFIC AND INDUSTRIAL EQUIPMENT
 3200 DWIGHT RD. SUITE 100
 ELK GROVE, CA, 95758
 916-395-3003 FAX: 916-395-3363
 www.gnbvalves.com

TITLE: **MEMBER, VERTICAL, STAND, MC TUBES**

DO NOT SCALE DRAWING

DWG. NO. **B** 114238-00M
 SCALE: 1:8 SHEET 1 OF 1

REV **A**