

PROPRIETARY AND CONFIDENTIAL
 THE INFORMATION CONTAINED IN THIS
 DRAWING IS THE SOLE PROPERTY OF
 GNB CORPORATION. ANY
 REPRODUCTION IN PART OR AS A WHOLE
 WITHOUT THE WRITTEN PERMISSION OF
 GNB CORPORATION IS PROHIBITED.

REVISIONS				
ZONE	REV.	DESCRIPTION	DATE	APPROVED
	A	RELEASED TO PRODUCTION	8/24/2010	MKM2

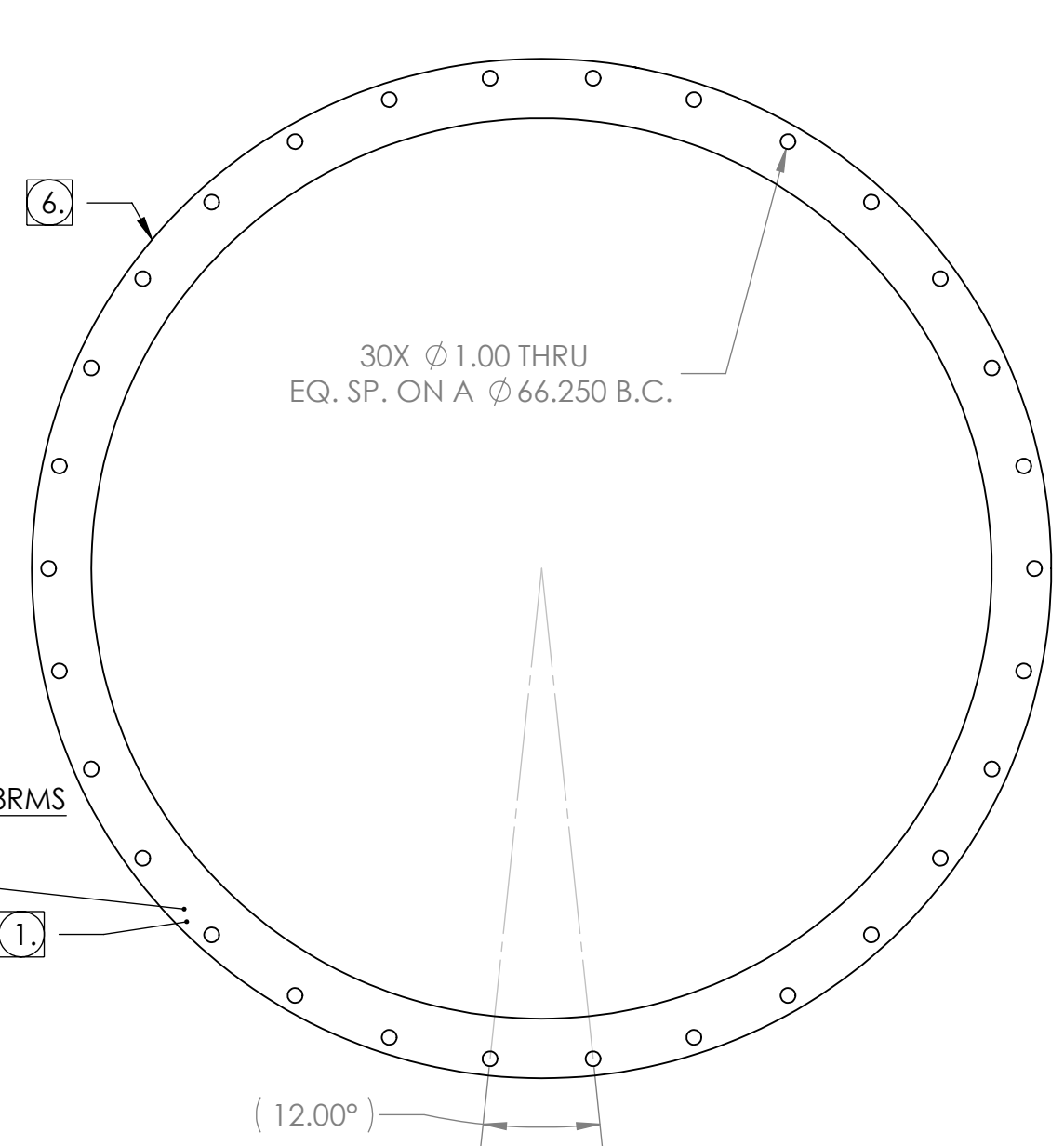
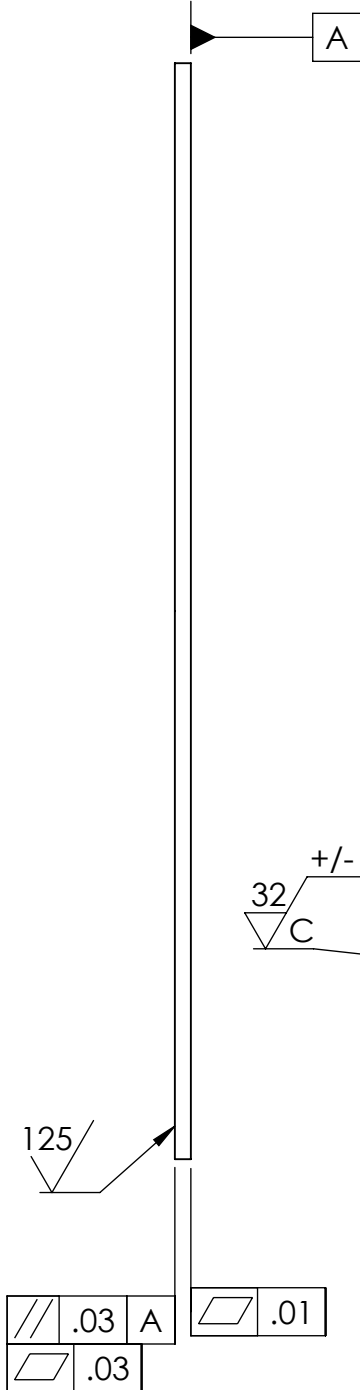
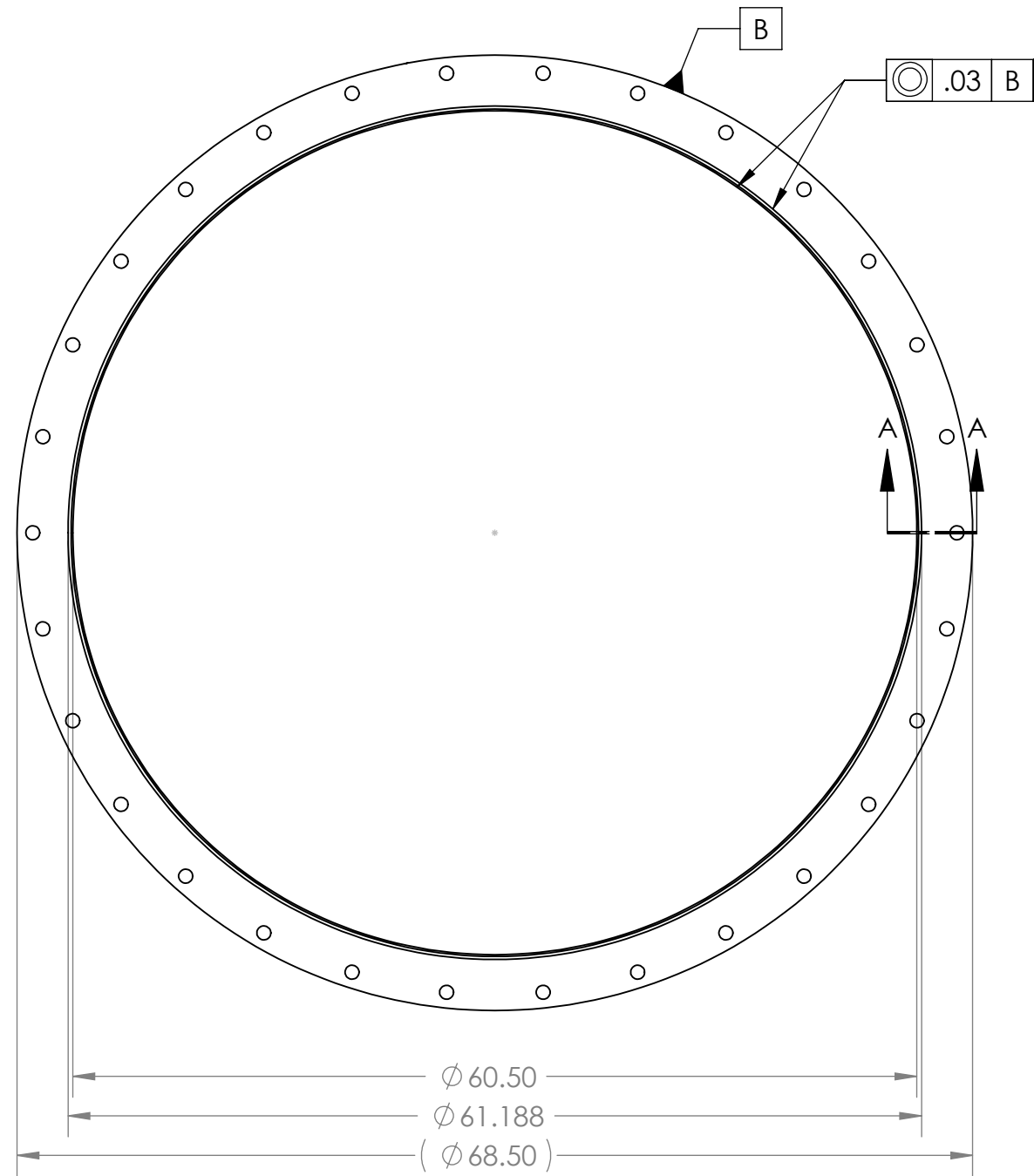

NOTES:

- 1. VACUUM SEALING SURFACE
- 2. THE FOLLOWING ARE NOT ALLOWED: GRINDING, HONING, LAPPING, POLISHING, BUFFING, SANDING, BLASTING.
- 3. NO HYDROCARBONS ALLOWED IN THE COOLANT. COOLANT LIMITS AS FOLLOWS
 - a. WATER LEACHABLE CHLORIDES: 100PPM
 - b. TOTAL HALOGENS (INCLUDING CHLORIDES): 1000PPM
 - c. TOTAL SULFUR: 1000PPM
- 4. DO NOT ALLOW PART TO BE CONTAMINATED BY CARBON STEEL OR IRON CONTACT.
- 5. MACHINING TO BE IN LINE WITH LIGO SPECIFICATION E0900406, LATEST REVISION.
- 6. DO NOT MACHINE OD OF FORGING; FORGING MANUFACTURER'S NUMBERS TO REMAIN INTACT

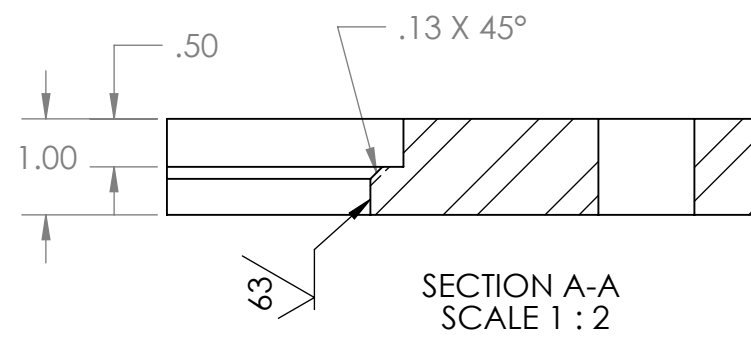

ITEM NO.	PART NUMBER	DESCRIPTION	QTY.
1	114259-00S	FORGING, FLANGE, 60.50 ID, 68.50 OD	1

MATERIAL: AISI 304L PER ASME SPEC SA182 GRADE F; MAX SULFUR CONTENT .006%

UNLESS OTHERWISE SPECIFIED:
 DIMENSIONS ARE IN INCHES
 TOLERANCES:
 ANGULAR: ± 0°30'
 .XX ± .03
 .XXX ± .005
 UNSPECIFIED FILLETS: R.015
 BREAK EDGES .010x45°
 REMOVE ALL BURRS

FINISH 125
 WITHIN .03

THIRD ANGLE PROJECTION



WEIGHT: 217.52#	
APPROVALS	DATE
DRAFTER MKM2	7/13/10
CHECKER RW	7/22/10
ENGINEER MKM2	7/13/10

GNB CORPORATION
 SCIENTIFIC AND INDUSTRIAL EQUIPMENT
 3200 DWIGHT RD. SUITE 100
 ELK GROVE, CA, 95758
 916-395-3003 FAX: 916-395-3363
 www.gnbvalves.com

TITLE: FLANGE, 60.50 ID, SMOOTH	
DO NOT SCALE DRAWING	DWG. NO. 114258-00S
SCALE: 1:12	SHEET 1 OF 1
REV A	