

PROPRIETARY AND CONFIDENTIAL
 THE INFORMATION CONTAINED IN THIS
 DRAWING IS THE SOLE PROPERTY OF
 GNB CORPORATION. ANY
 REPRODUCTION IN PART OR AS A WHOLE
 WITHOUT THE WRITTEN PERMISSION OF
 GNB CORPORATION IS PROHIBITED.

REVISIONS				
ZONE	REV.	DESCRIPTION	DATE	APPROVED
	A	RELEASED TO PRODUCTION	8/25/2010	MKM2

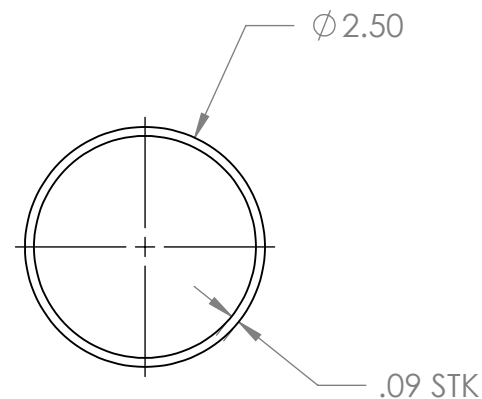
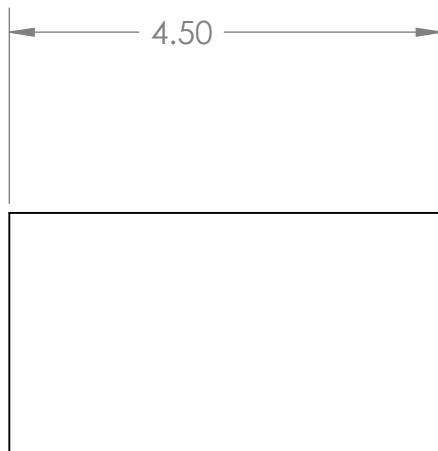

NOTES:

1. THE FOLLOWING ARE NOT ALLOWED: GRINDING, HONING, LAPPING, POLISHING, BUFFING, SANDING, BLASTING.
2. NO HYDROCARBONS ALLOWED IN THE COOLANT. COOLANT LIMITS AS FOLLOWS
 - a. WATER LEACHABLE CHLORIDES: 100PPM
 - b. TOTAL HALOGENS (INCLUDING CHLORIDES): 1000PPM
 - c. TOTAL SULFUR: 1000PPM
3. DO NOT ALLOW PART TO BE CONTAMINATED BY CARBON STEEL OR IRON CONTACT.
4. MACHINING TO BE IN LINE WITH QP1730-10, CCP

DESCRIPTION: TUBE, 2.5" OD, .09 WALL, 4.50 LG		<p>SCIENTIFIC AND INDUSTRIAL EQUIPMENT</p> <p>3200 DWIGHT RD, SUITE 100 ELK GROVE, CA 95758 916-395-3003 FAX: 916-395-3363 WWW.GNBVALVES.COM</p>															
MATERIAL: AISI 304/ AISI 304L DUAL CERT PER SA 240																	
UNLESS OTHERWISE SPECIFIED:	WEIGHT: 0.92 #	<table border="1"> <thead> <tr> <th colspan="3">APPROVALS</th> </tr> <tr> <th></th> <th>NAME</th> <th>DATE</th> </tr> </thead> <tbody> <tr> <td>DRAFTER</td> <td>MKM2</td> <td>6/25/10</td> </tr> <tr> <td>CHECKER</td> <td>RW</td> <td>7/22/10</td> </tr> <tr> <td>ENGINEER</td> <td>MKM2</td> <td>6/25/10</td> </tr> </tbody> </table>	APPROVALS				NAME	DATE	DRAFTER	MKM2	6/25/10	CHECKER	RW	7/22/10	ENGINEER	MKM2	6/25/10
APPROVALS																	
	NAME		DATE														
DRAFTER	MKM2		6/25/10														
CHECKER	RW	7/22/10															
ENGINEER	MKM2	6/25/10															
DIMENSIONS ARE IN INCHES																	
TOLERANCES: FINISH																	
ANGULAR: $\pm 0^{\circ}30'$	$\nabla 125$																
.XX $\pm .01$																	
.XXX $\pm .005$																	
UNSPECIFIED FILLETS: R.015																	
BREAK EDGES .010 x 45°																	
REMOVE ALL BURRS																	
\parallel \square \perp WITHIN .03																	
THIRD ANGLE PROJECTION																	
<u>DO NOT SCALE DRAWING</u>		TITLE: TUBE, 4.5" CF PORT DWG. NO. A 114220-00S SCALE: 1:2															