

REV.	DATE	DCN #	DRAWING TREE #
V1	20 Aug 2010	E1000340	

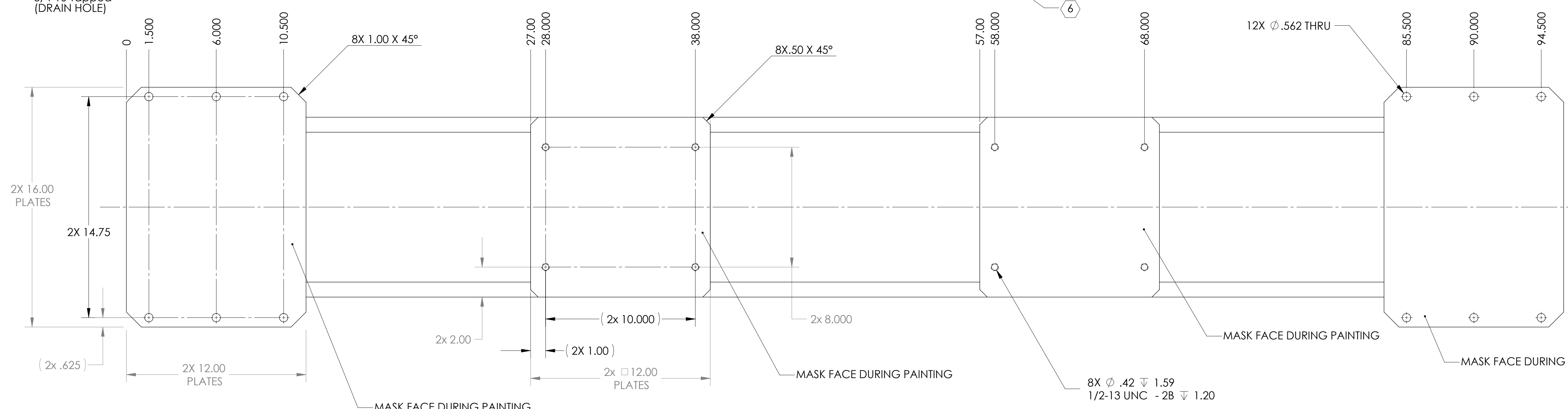
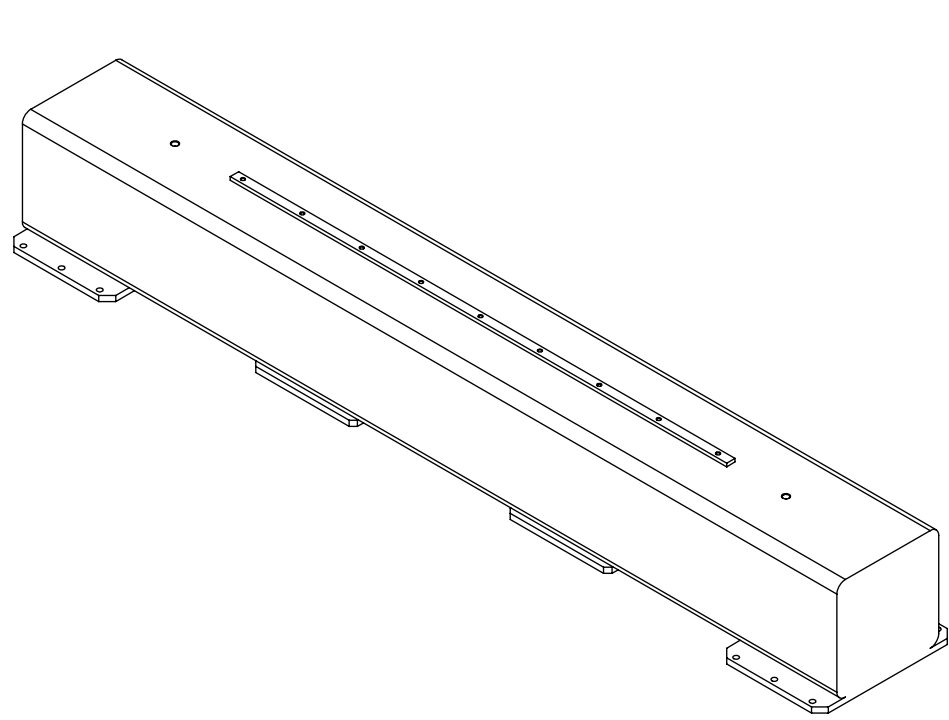
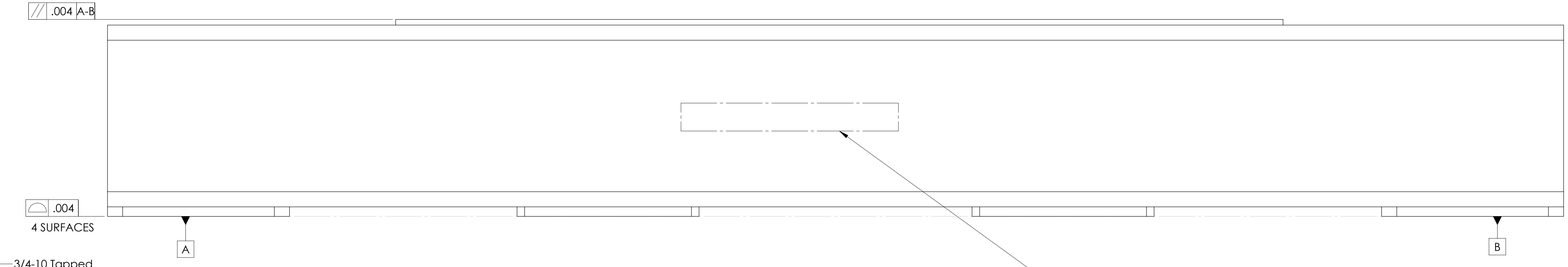
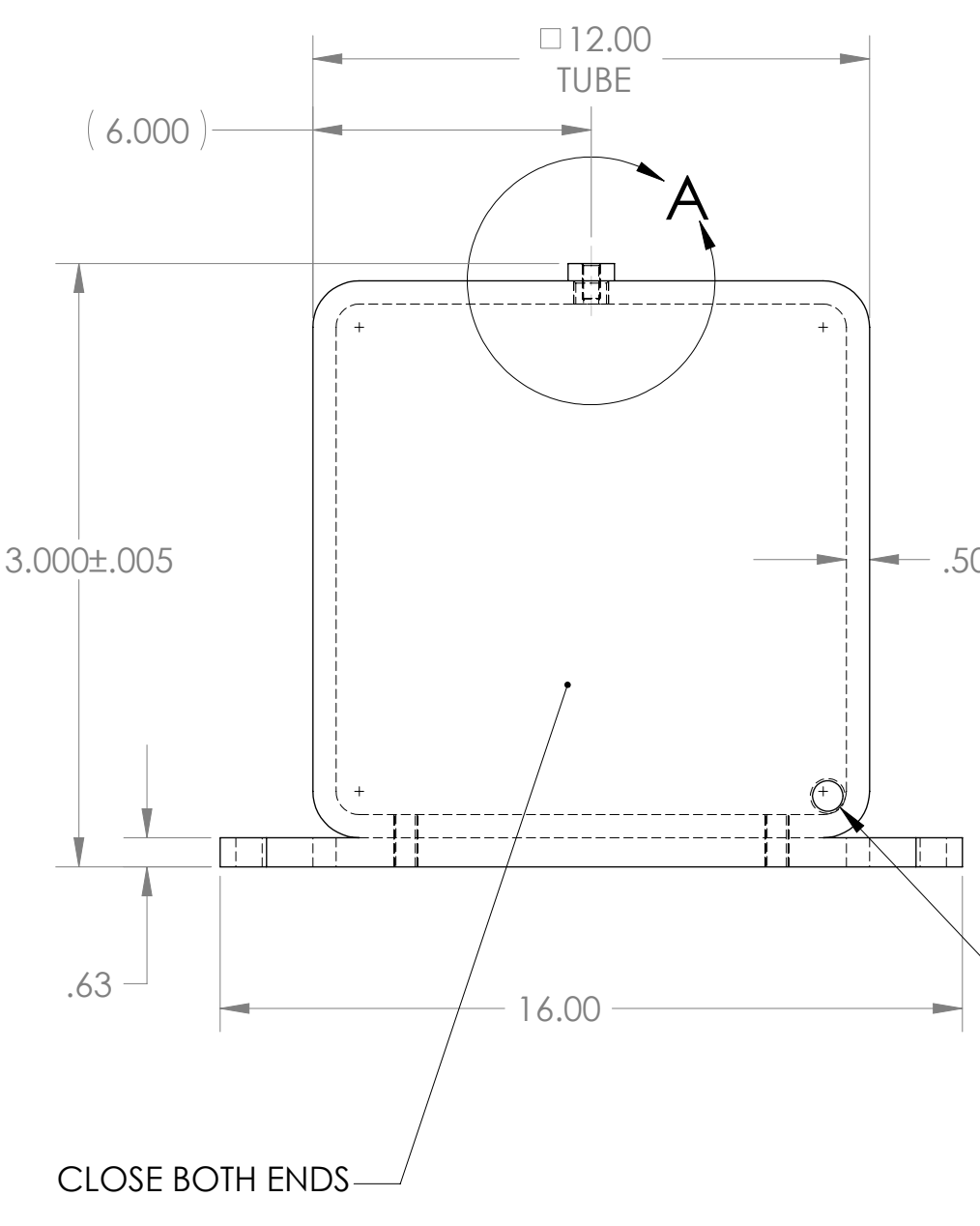
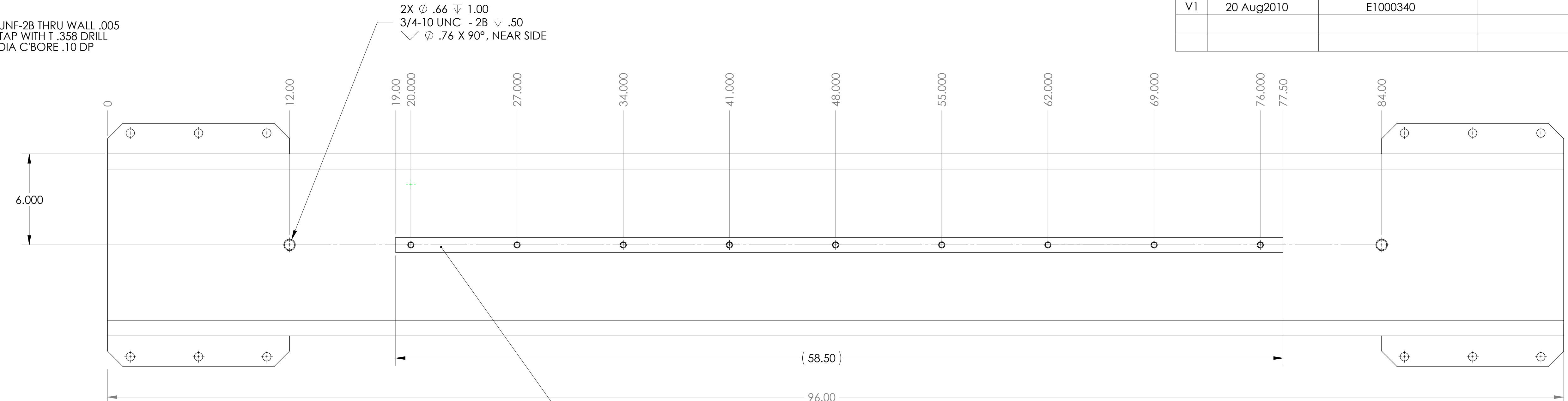
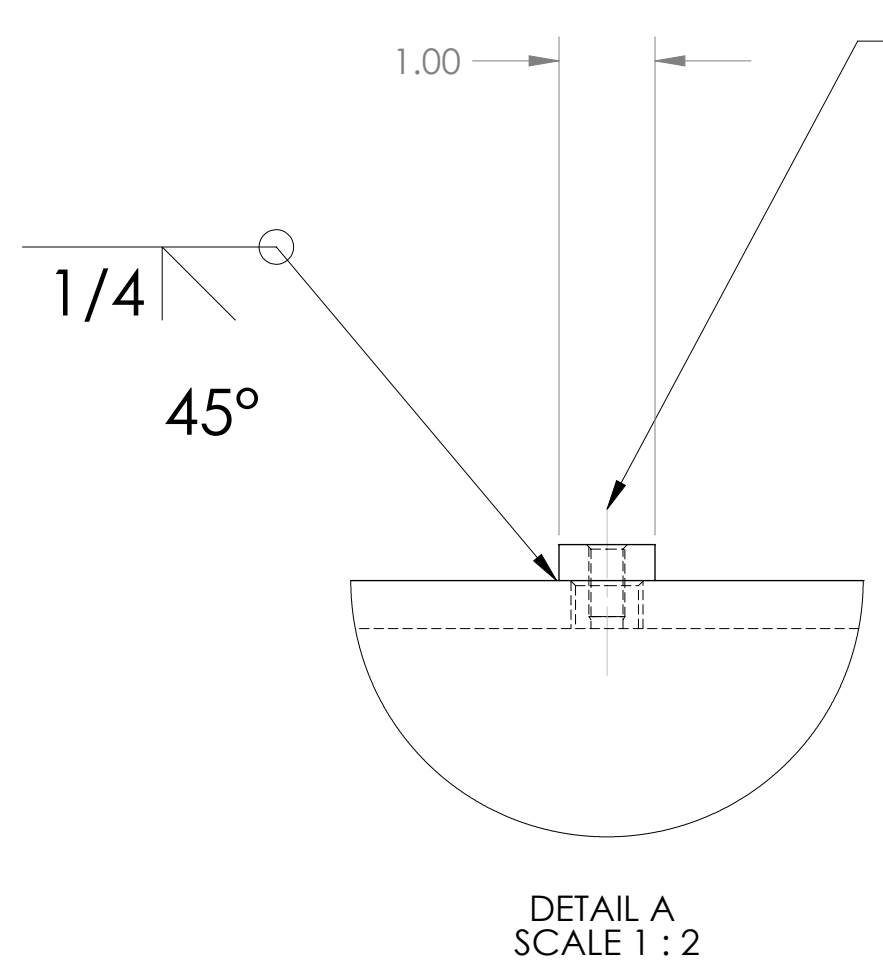

- NOTES CONTINUED:
- FULL WELDED CONSTRUCTION.
 - PART NUMBER (DRAWING NO. PLUS REVISION) TO BE CLEARLY MARKED ON THE PART NEAR LOCATION SHOWN
EXAMPLE : **D1002127-V1** (~ 1" CHARACTERS)
 - BEFORE FINISHING REMOVE ALL: MILL SCALE, OXYDATION, GREASE, OIL, DIRT, FINGERPRINTS, CONTAMINANTS, ETC.
 - PRIME WITH SHERWIN WILLIAMS INDUSTRIAL WASH PRIMER "P60G2" PER SPECIFICATON.
 - PAINT SMOOTH WHITE, SHERWIN WILLIAMS "POLANE HS-PLUS" POLYURETHANE ENAMEL P/N F63W66.

NOTES AND TOLERANCES: (UNLESS OTHERWISE SPECIFIED)	
DIMENSIONS ARE IN INCHES	
TOLERANCES: .XX ± .025 .XXX ± .010	
ANGULAR ± 0.5°	
MATERIAL	FINISH
ASTM a500 Grade-B	125 μ inch

CALIFORNIA INSTITUTE OF TECHNOLOGY MASSACHUSETTS INSTITUTE OF TECHNOLOGY	
SYSTEM	SUB-SYSTEM
ADVANCED LIGO	SEI
NEXT ASSY	D1002124

PART NAME			
Support Tube, Stand, Test Only, BSC-ISI-Quad, aLIGO			
DESIGNER	SBARNUM	10 Aug 2010	SIZE DWG. NO.
DRAFTER	sbarnum	17 Aug 2010	D
CHECKER			D1002127
APPROVAL	kmason		REV. v1
SCALE: 1:1		PROJECTION:	SHEET 1 OF 1

D1002127 Support Tube Stand Test Only, BSC-ISI-Quad, aLIGO, PART PDM REV: X-001, DRAWING PDM REV: X-000