

REV.	DATE	DCN #	DRAWING TREE #
-	-	-	-
-	-	-	-
-	-	-	-

Storage Container Assembly

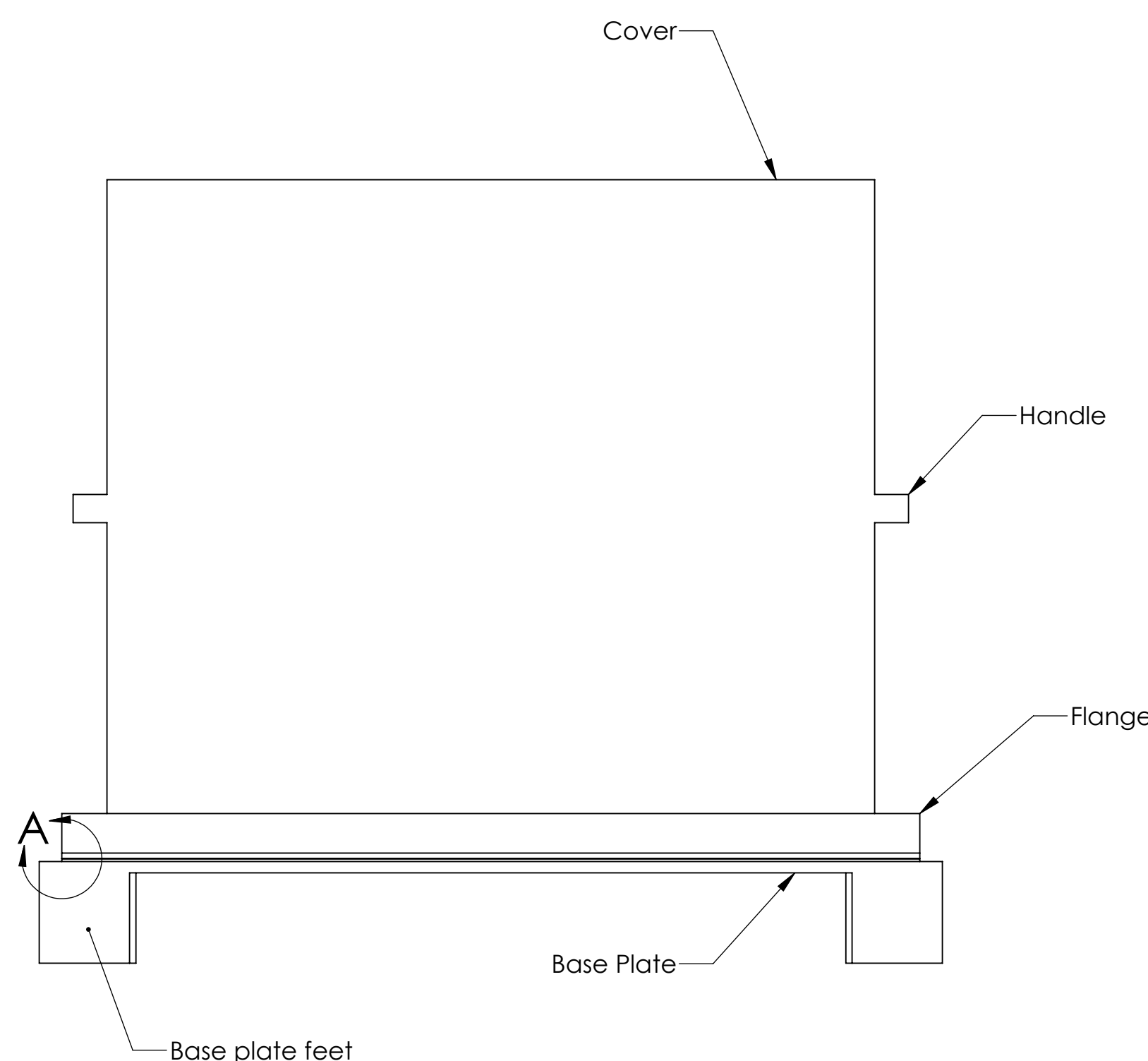

Removable 3/16"x2" Viton Gasket Provided by LIGO

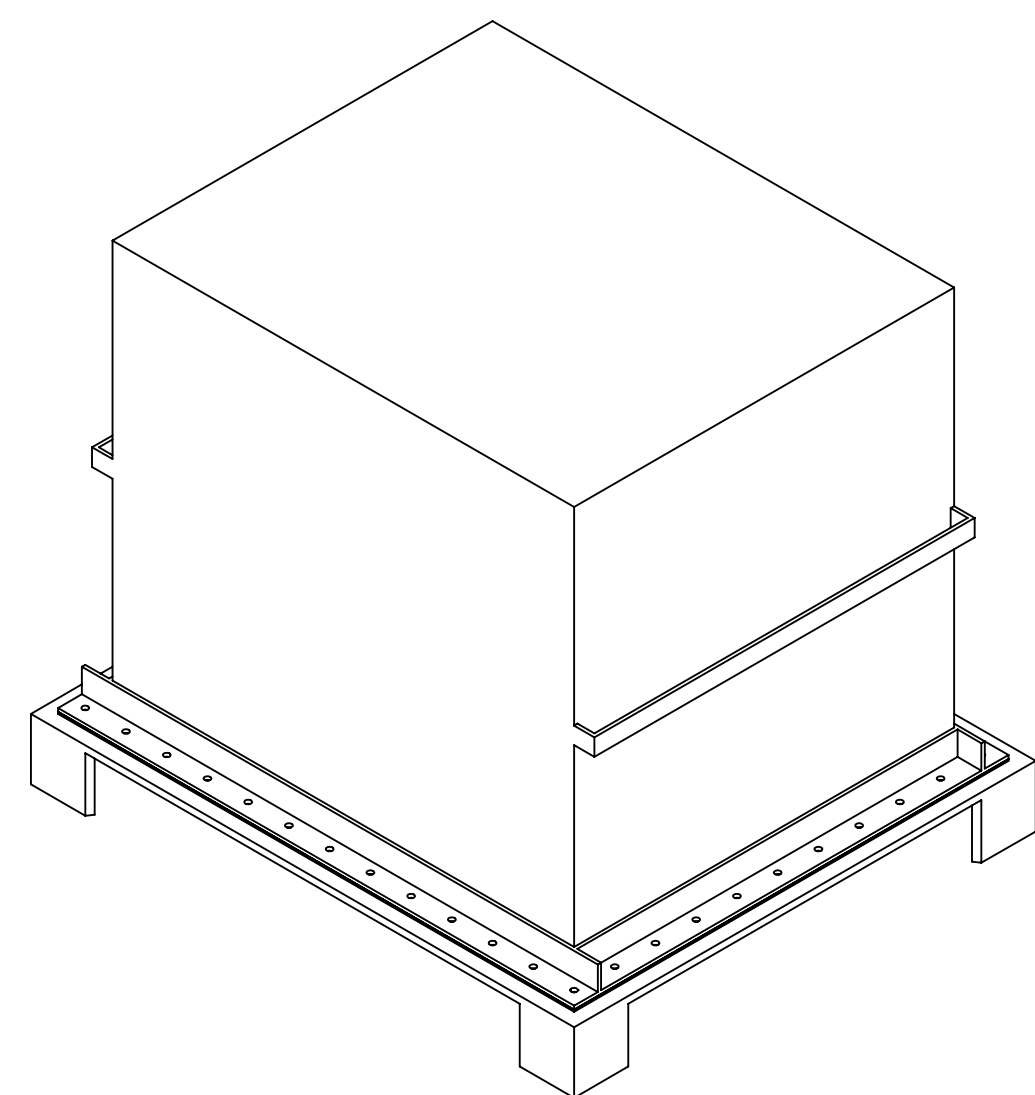
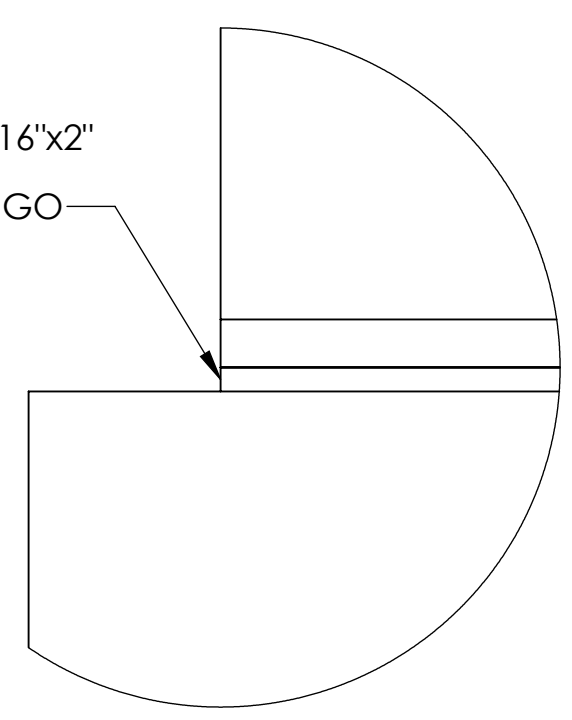

DETAIL A
SCALE 1 : 1

ITEM NO.	PART NUMBER	QTY.
1	Upper Structure Cover	1
2	Upper Structure Base Plate	1
3	Flat Viton Gasket	1

NOTES AND TOLERANCES: (UNLESS OTHERWISE SPECIFIED)

1. INTERPRET DRAWING PER ASME Y14.5-1994.
 2. REMOVE ALL SHARP EDGES, R.02 MIN.
 3. DO NOT SCALE FROM DRAWING.
 4. ALL MACHINING FLUIDS MUST BE FULLY SYNTHETIC, FULLY WATER SOLUBLE AND FREE OF SULFUR, SILICONE, AND CHLORINE.

DIMENSIONS ARE IN
 TOLERANCES:
 .XX ± REFER TO NOTES ON SHEET 2 and 3
 .XXX ±
 ANGULAR ± °

MATERIAL
 6061 or 5052 Aluminum

FINISH
 refer to notes

LIGO CALIFORNIA INSTITUTE OF TECHNOLOGY
 MASSACHUSETTS INSTITUTE OF TECHNOLOGY

SYSTEM SUB-SYSTEM
 SUS

NEXT ASSY

PART NAME
 Upper Structure Storage Container

DESIGNER Jim Warner
 DRAFTER
 CHECKER
 APPROVAL

SIZE DWG. NO.
 c D1002222

SCALE: 1:8 PROJECTION:

REV. v6

SHEET 1 OF 3

44 x \varnothing .41 Thru holes
1" From Edge
3" Spacing

32.00

38.00

34.00

28.00

Welded cover

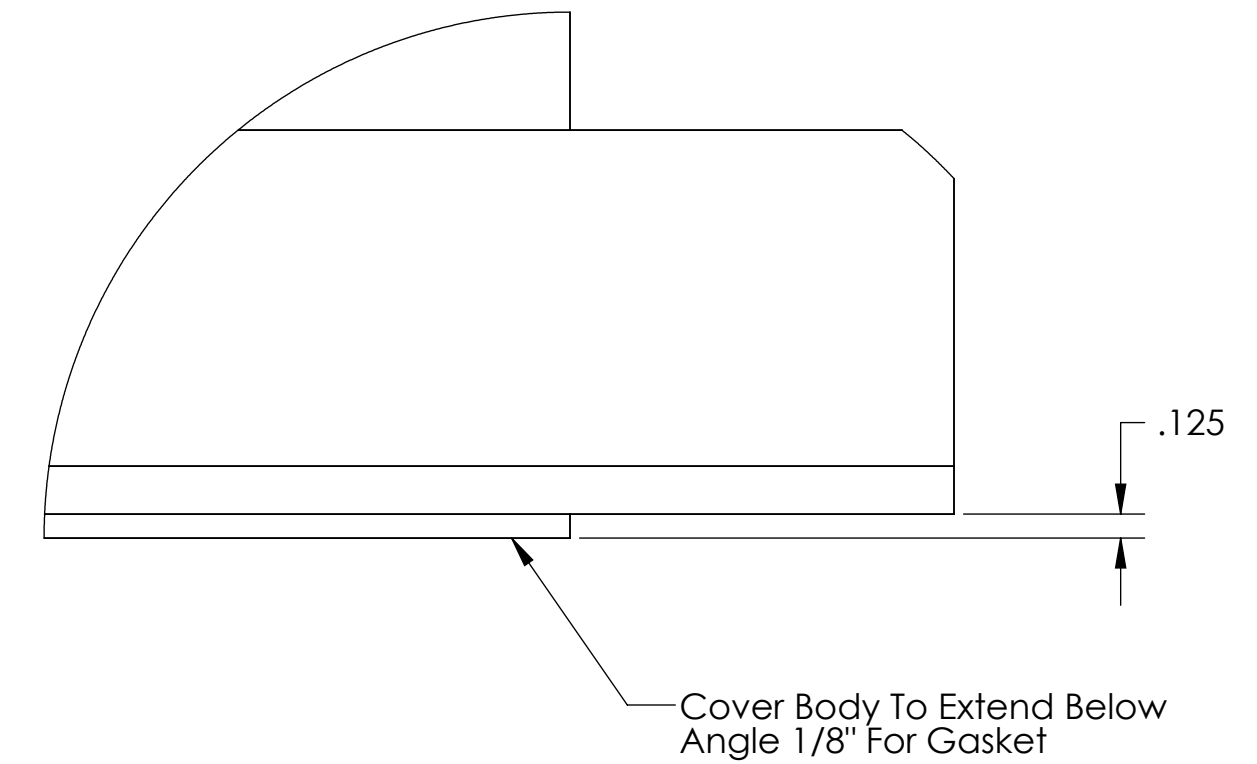
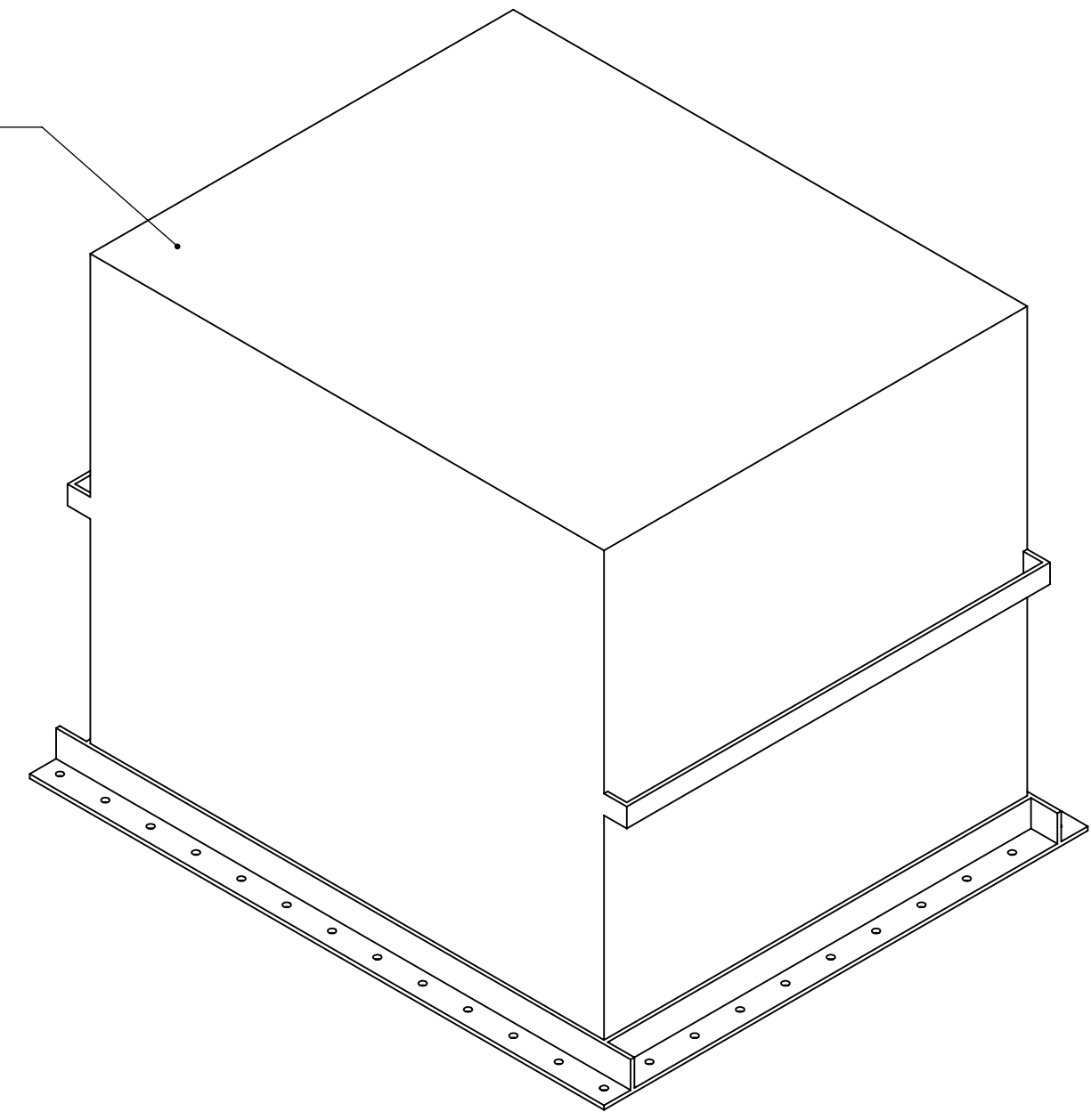
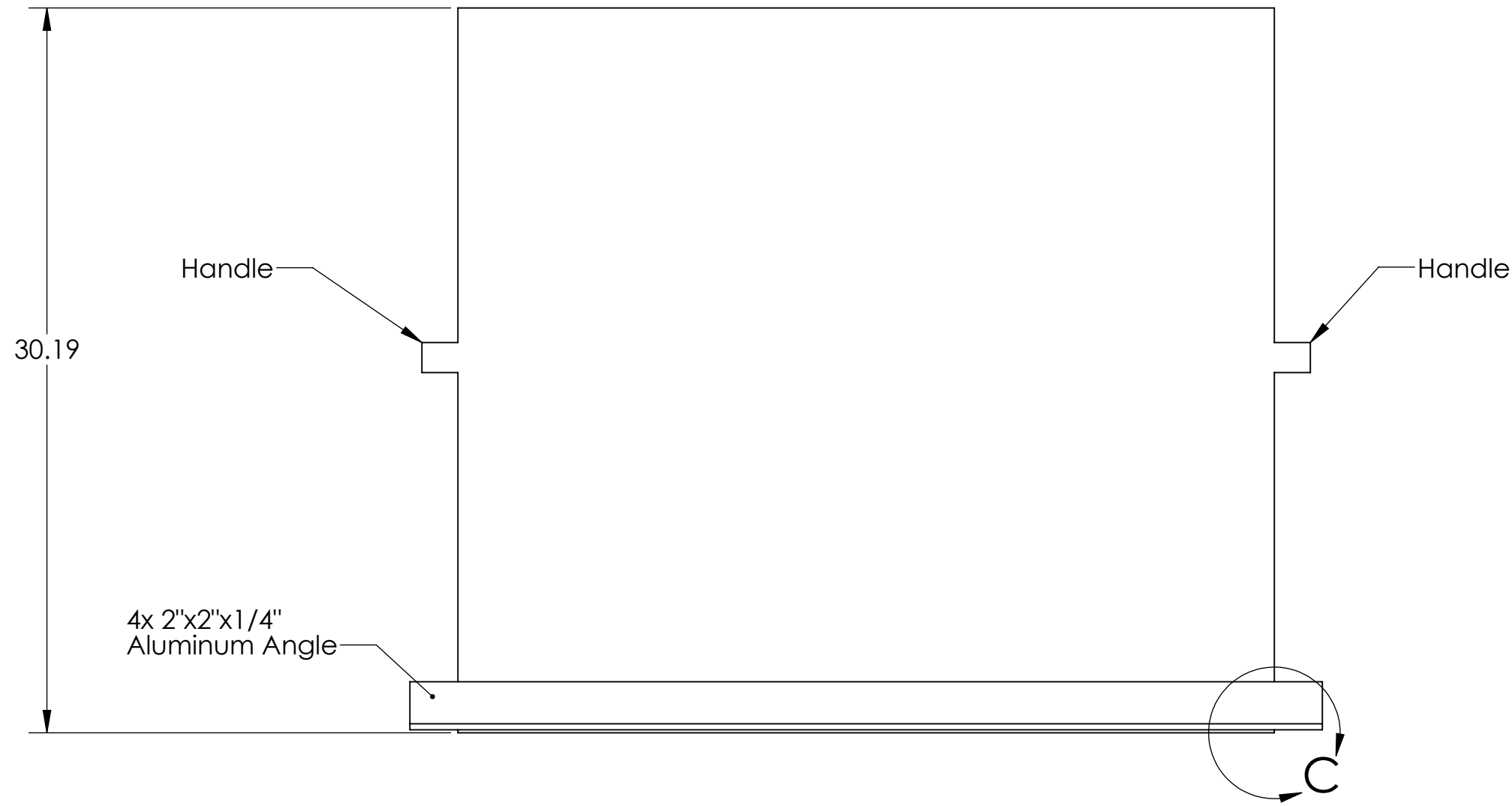

DETAIL C
SCALE 1 : 1

I. ALUM WELDED COVER BOX (INCLUDING HANDLES)

5. Use 1/16" 6061 or 5052 Aluminum Sheet for 5-sided cover and handles.
6. 32 micor-inch finish as rec from supplier. If surface finish is higher than the standard 32 Ra micro-inch, the surface finish shall be discussed with LIGO officer prior to acceptance.
7. Minimum of 2 handles to be welded at midpoint of the cover such that seal is unaffected, location not critical.
8. Prior to welding all parts must be thoroughly cleaned to remove all oil, grease, ink markings, dirt and chips using soap and water or solvent (acetone)

9. ALL DIMENSIONS APPLY AFTER WELDING. ALL WELDS MUST BE FULL PENETRATION AND FULL FUSION WELDS. THE CONTAINER SHOULD FULLY SEAL AT THE WELDS, SUCH THAT THE CONTAINER IS AIR TIGHT. NO TRAPPED VOLUMES ARE PERMITTED. WELDMENTS WITH CREVICES ARE CONSIDERED NON-CLEANABLE SINCE THESE CREVICES ACT AS TRAPS FOR CLEANING SOLUTIONS. ALL WELDS SHALL BE DONE ON THE INTERIOR OF THE CONTAINER SUCH THAT NO SEAMS ARE EXPOSEDON THE INTERIOR OF THE BOX. SEAMS WILL TRAP CONTAMINATION AND BE HARD TO CLEAN. ALL WELDERS SHOULD BE CERTIFIED TO AMERICAN WELDING SOCIETY (AWS).

10. All interior dims +/- 0.010", exterior dims are +/- .125"
11. Chemical cleaning might be a required step post-fabrication as per E090364, section 5

II. ALUM ANGLE FOR COVER FLANGE

12. Use 4x 2"x2"x1/4" Aluminum angle for cover flange.
13. Material to be chosen such that localized digs, scratches and blemishes is minimized.
14. All interior dims +/- 0.010", exterior dims are +/- .125"

 CALIFORNIA INSTITUTE OF TECHNOLOGY MASSACHUSETTS INSTITUTE OF TECHNOLOGY		REV.
SIZE C	DWG. NO. Cover	v6
SCALE: 1:8	PROJECTION: 	SHEET 2 OF 3

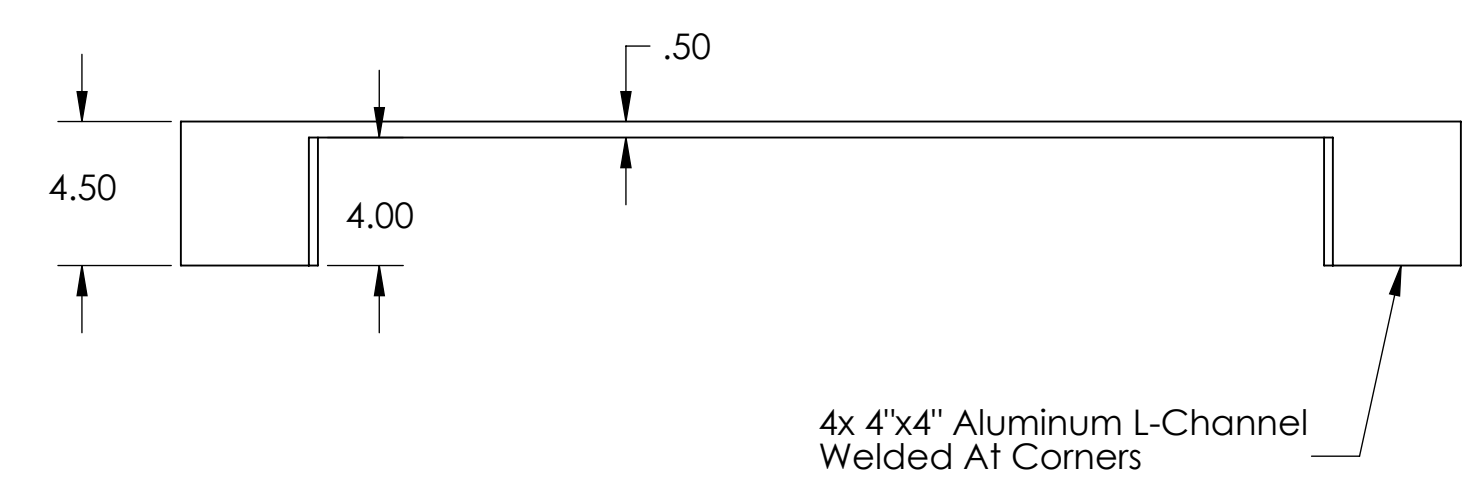
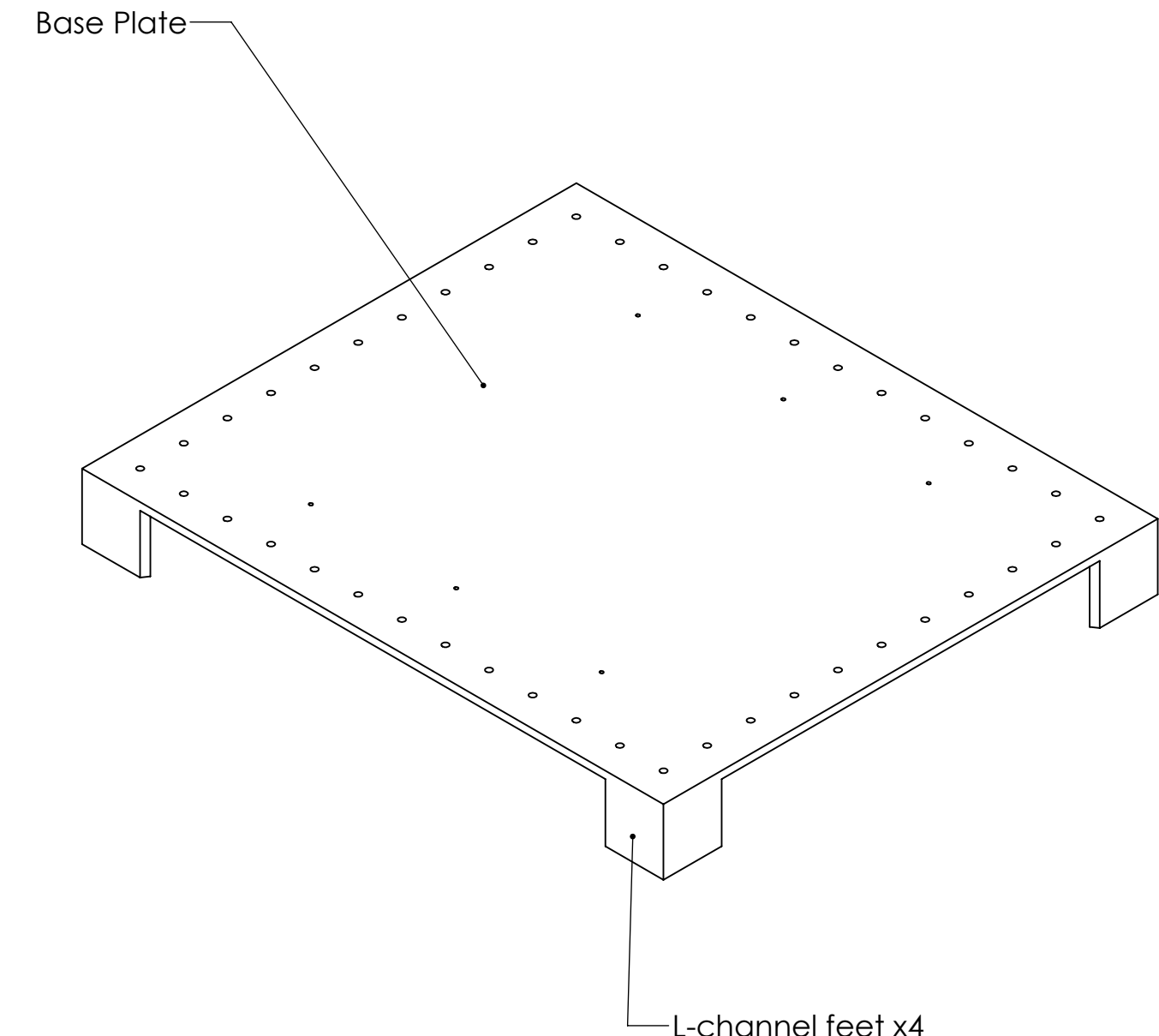
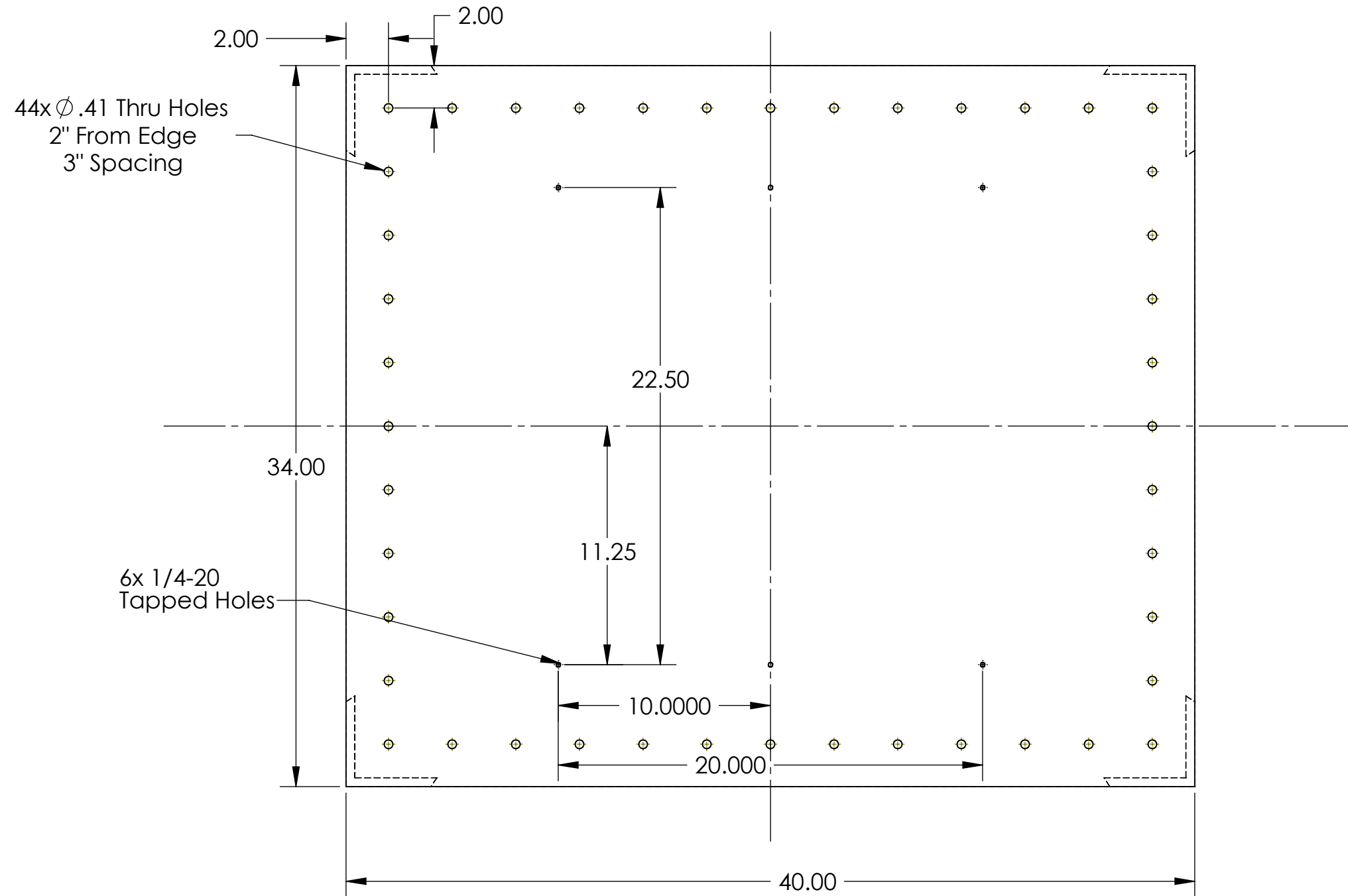

III. ALUM BASE PLATE

- 15. Machine all surfaces of 1/2" plate.
- 16. Use 5052 or 6061-T6-Al 1/2" Aluminum Plate
- 17. All interior dims +/- 0.010", exterior dims are +/- .125"

IV. ALUM L-CHANNEL (FEET)

- 18. Use 4x 4"x4"x1/2" Aluminum angle for feet.
- 19. Material to be chosen such that localized digs, scratches and blemishes is minimized.
- 20. All interior dims +/- 0.010", exterior dims are +/- .125"

- 21. Feet to be welded to base plate at corners,
- 22. Full seal welds on cover to be done from interior of cover.
- 23. Chemical cleaning might be a required step post-fabrication as per E090364, section 5

 CALIFORNIA INSTITUTE OF TECHNOLOGY MASSACHUSETTS INSTITUTE OF TECHNOLOGY		REV. v6
SIZE C	DWG. NO. Base Plate	
SCALE: 1:8	PROJECTION:	SHEET 3 OF 3