

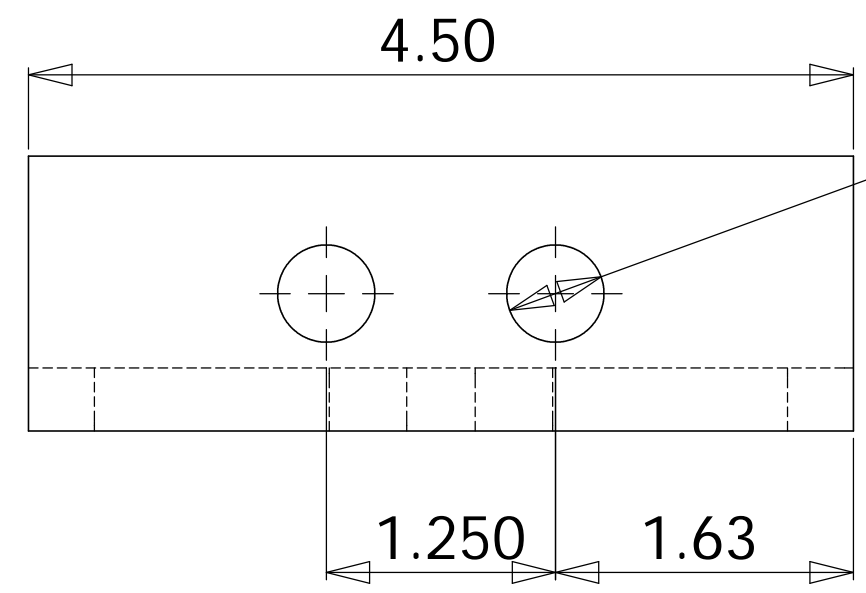

- NOTES: UNLESS OTHERWISE SPECIFIED
1. REMOVE ALL BURRS AND BREAK SHARP EDGES TO A MAXIMUM OF .015
 2. PART NUMBER (DRAWING NO., DASH NO., REVISION NO., SERIAL NO.) TO BE CLEARLY MARKED ON THE PART ITSELF
 3. PAINT:
ALL VISIBLE SURFACES
MEDIUM BLUE SHERWIN WILLIAMS (POLANE (R) T-PLUS POLYURETHANE ENAMEL) #SW-F63TX-L-2822-5864
PRIME WITH SHERWIN WILLIAMS INDUSTRIAL WASH PRIMER P60G2
 4. "OXI SOLV RUST INHIBITOR" TO BE APPLIED PER MFG. INSTRUCTIONS TO ALL UNPAINTED SURFACES.
BOTH TAPPED AND THRU HOLES WILL BE PLUGGED DURING APPLICATION.

REV.	DATE	DCN #	DRAWING TREE #

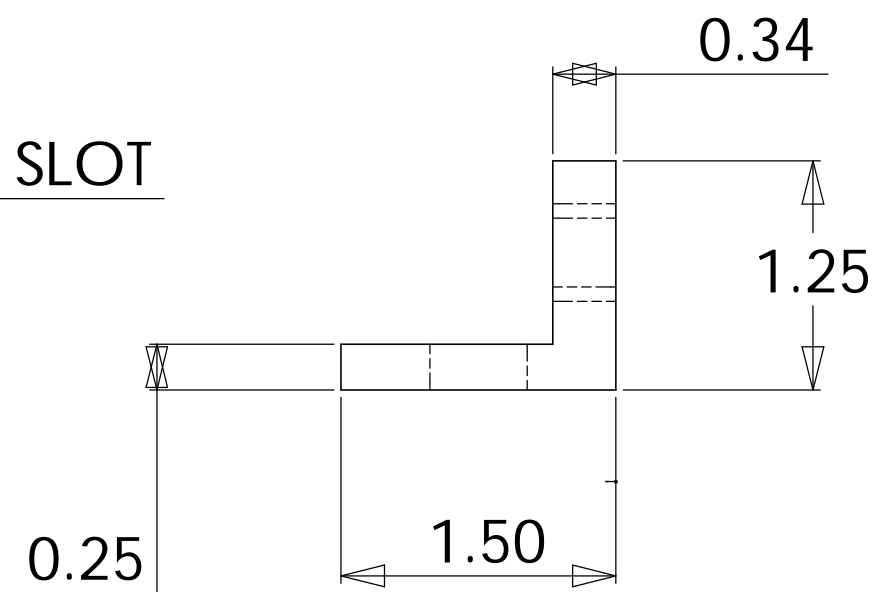
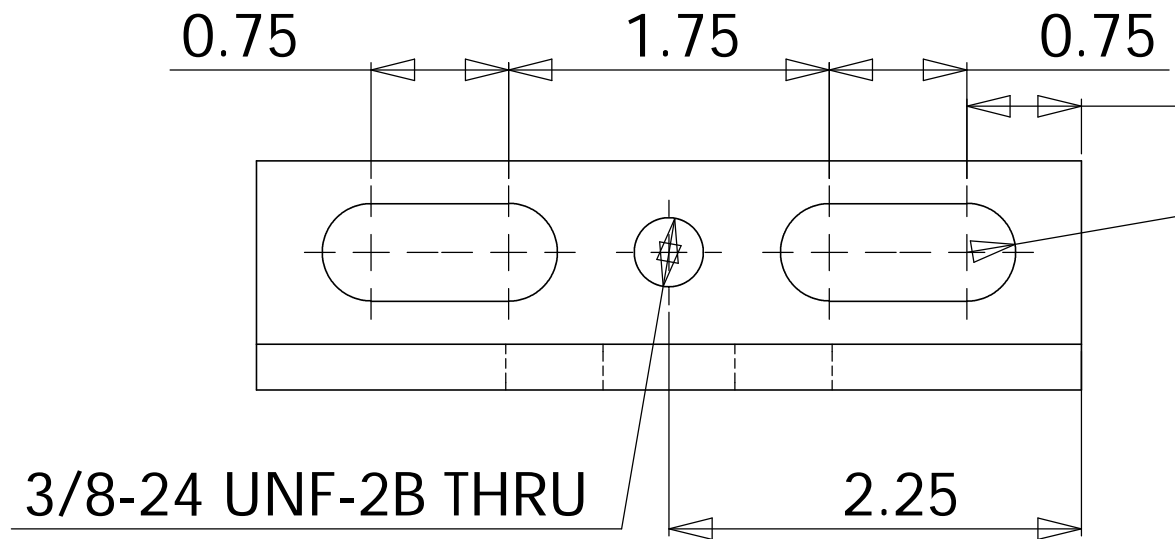

ITEM NO.	REQ. QUANTITY	SPARE	TOT.	PART NUMBER	DESCRIPTION	SUPPLIER
PARTS LIST						
UNLESS OTHERWISE SPECIFIED: DIMENSIONS ARE IN INCHES TOLERANCES: .XX ±: .02 .XXX ±: .005 ANGULAR: ±1 DEG				DATE 5/6/02	NAME KMASON	 CALIFORNIA INSTITUTE OF TECHNOLOGY MASSACHUSETTS INSTITUTE OF TECHNOLOGY
MATERIAL 1018 CRS				COMMENTS:		SYSTEM SUB-SYSTEM NEXT ASSY: HYDRAULIC PRE-ISOLATOR ASSEMBLY PART NAME: UPPER ACTUATOR PLATE SHORT
FINISH SEE NOTES				SIZE B	DWG. NO. D020014-A-D	REV A
				SCALE: 1:1	D020014-A.SLDPRT	SHEET 1 OF 1