

- NOTES: UNLESS OTHERWISE SPECIFIED
1. REMOVE ALL BURRS AND BREAK SHARP EDGES TO A MAXIMUM OF .015
 2. PART NUMBER (DRAWING NO., DASH NO., REVISION NO., SERIAL NO.) TO BE CLEARLY MARKED ON THE PART ITSELF
 3. PAINT:
ALL VISIBLE SURFACES
MEDIUM BLUE SHERWIN WILLIAMS (POLANE (R) T-PLUS POLYURETHANE ENAMEL) #SW-F63TX-L-2822-5864
PRIME WITH SHERWIN WILLIAMS INDUSTRIAL WASH PRIMER P60G2
 4. BOTH TAPPED AND THRU HOLES WILL BE PLUGGED DURING APPLICATION.

REV.	DATE	DCN #	DRAWING TREE #

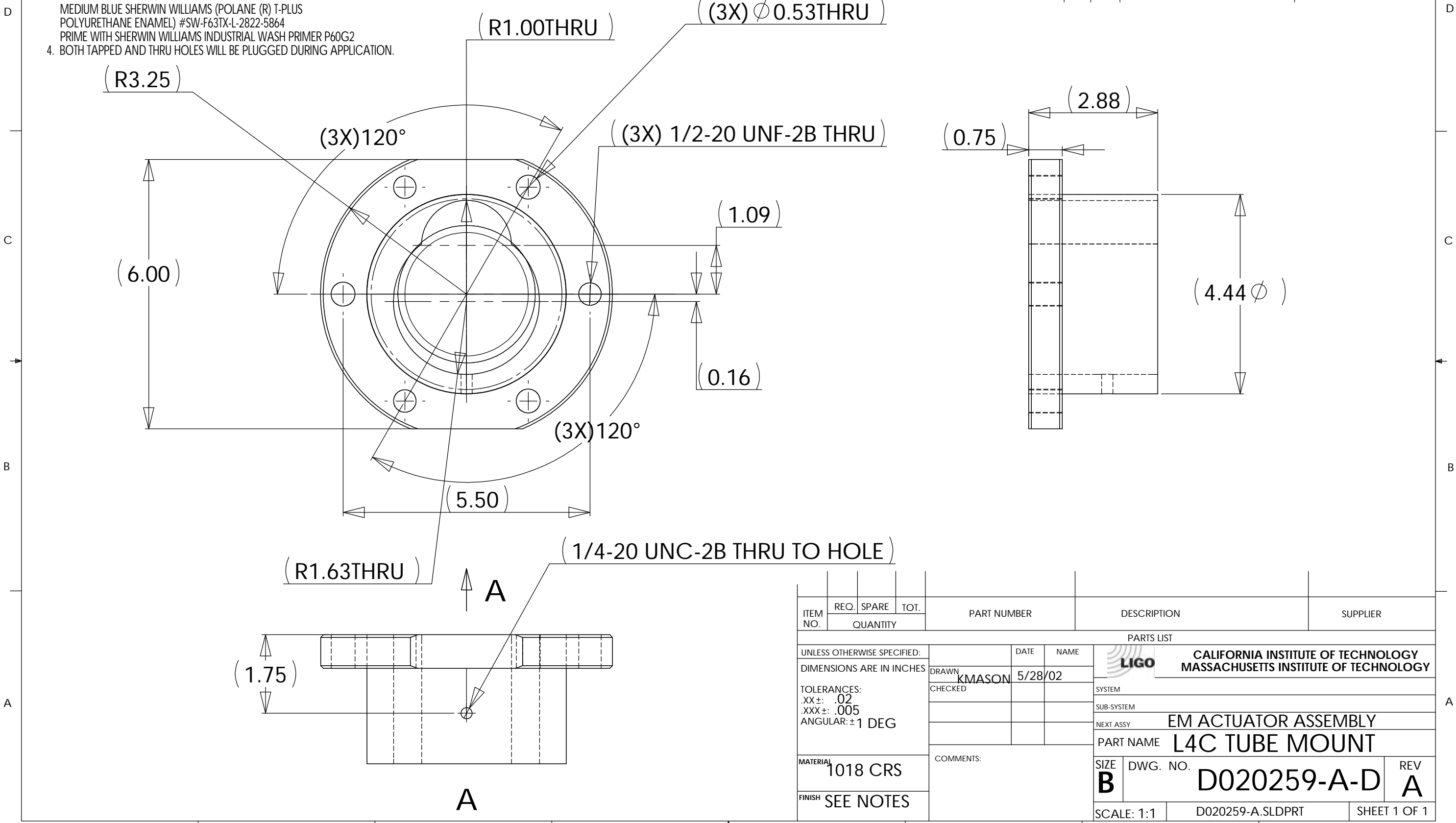

ITEM NO.	REQ. QUANTITY	SPARE	TOT.	PART NUMBER	DESCRIPTION	SUPPLIER
PARTS LIST						
UNLESS OTHERWISE SPECIFIED: DIMENSIONS ARE IN INCHES TOLERANCES: .XX ±: .02 .XXX ±: .005 ANGULAR: ± 1 DEG				DRAWN KMASON	DATE 5/28/02	NAME LIGO CALIFORNIA INSTITUTE OF TECHNOLOGY MASSACHUSETTS INSTITUTE OF TECHNOLOGY
MATERIAL 1018 CRS				SYSTEM		
FINISH SEE NOTES				SUB-SYSTEM		
				NEXT ASSY EM ACTUATOR ASSEMBLY		
				PART NAME L4C TUBE MOUNT		
				SIZE B	DWG. NO. D020259-A-D	REV A
				SCALE: 1:1	D020259-A.SLDPRT	SHEET 1 OF 1