

NOTES: (UNLESS OTHERWISE SPECIFIED)

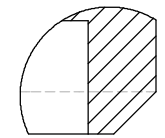

DETAIL A
SCALE 4 : 1

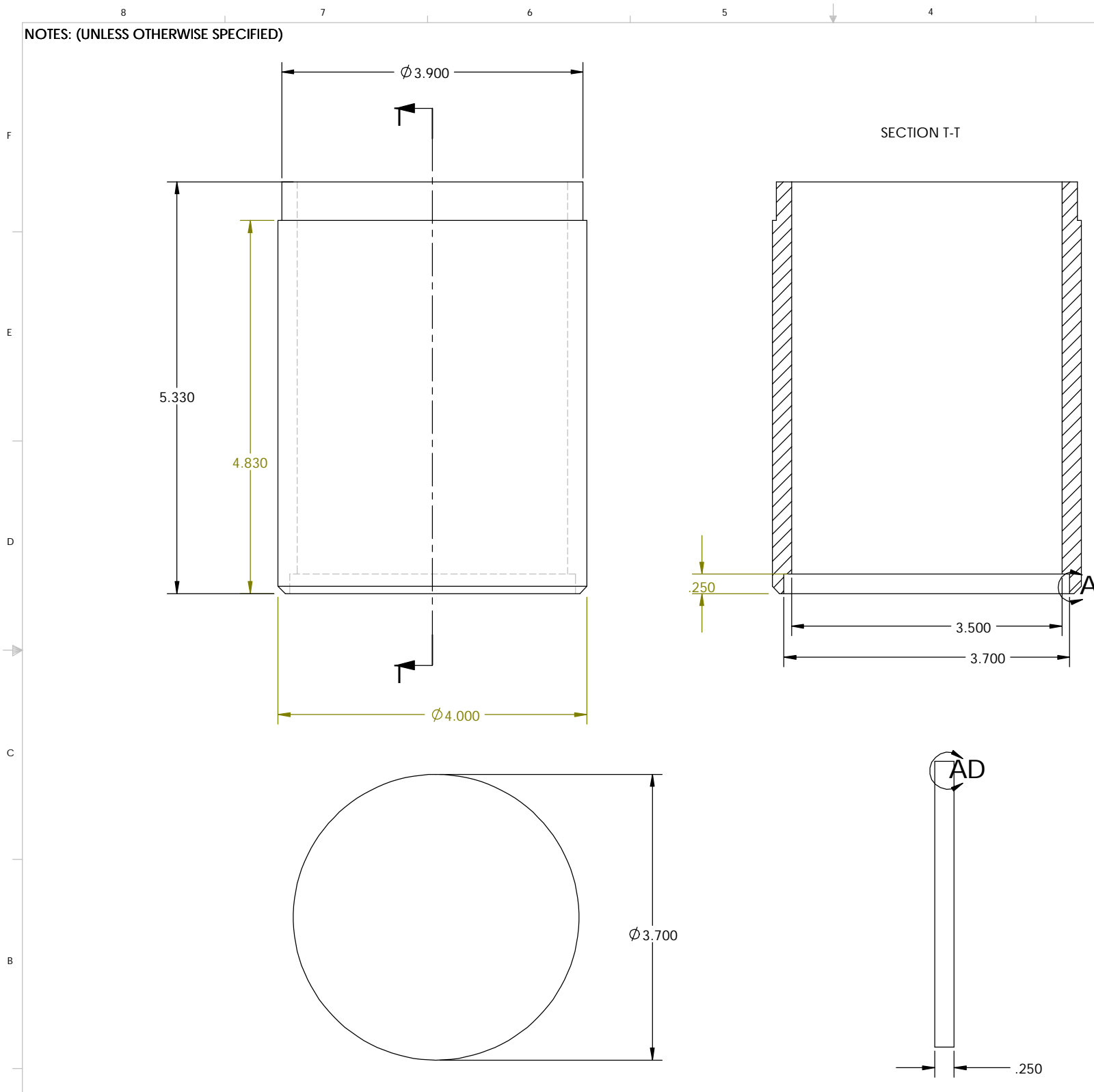
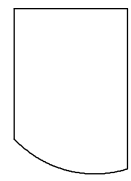

DETAIL AD
SCALE 4 : 1

ITEM NO.	REQ. QUANTITY	SPARE QUANTITY	TOT. QUANTITY	PART NUMBER	DESCRIPTION	SUPPLIER
<p>PARTS LIST</p> <p>UNLESS OTHERWISE SPECIFIED: DRAWN: 4/02 NAME: Hardham DIMENSIONS ARE IN INCHES TOLERANCES: .XX ± 0.02" .XXX ± 0.001" ANGULAR ± 30" MATERIAL: 304 SS FINISH:</p>						
				DATE: 4/02	CALIFORNIA INSTITUTE OF TECHNOLOGY MASSACHUSETTS INSTITUTE OF TECHNOLOGY	
				REDRAWN: 5/23/02	SYSTEM: LASTI	
				CHECKED: 5/21/02	SUB-SYSTEM: HEPI	
					NEXT ASSY:	
					PART NAME: Top Bel l ow Sl ug & Cap	
				COMMENTS: 1 Required for each actuator	SIZE: C	DWG. NO.: D020291-00-E
					SCALE:	REV:

6 RQG: RUN (GXFDMRQDOLFHQVH
 ,QVWKFVRQD8 VH2 Q0