

REV.	DATE	DCN. #	DRAWING TREE #

NOTES: (UNLESS OTHERWISE SPECIFIED)

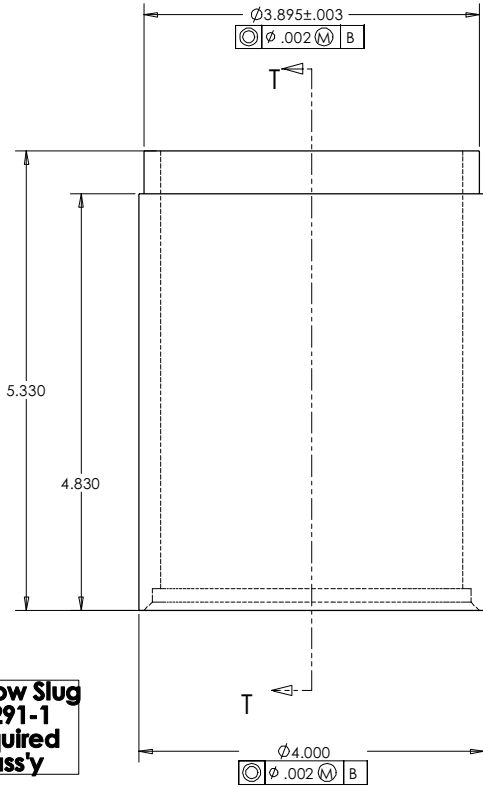

**Top Bellow Slug  
D020291-1  
(1) required  
per ass'y**

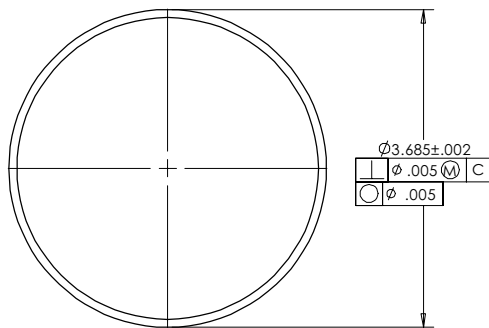

**Top Bellow Cap  
D020291-2  
(1) required  
per ass'y**

SECTION T-T

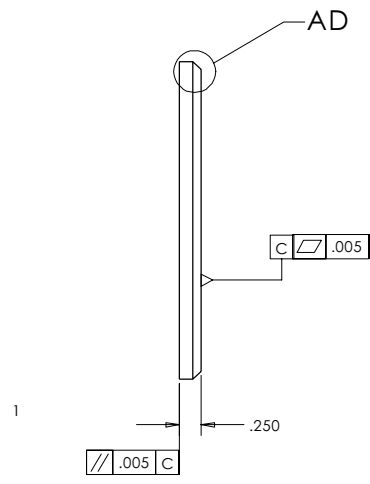
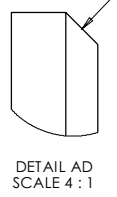
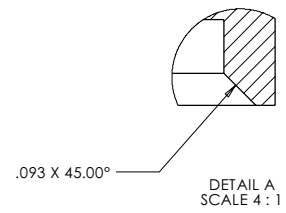
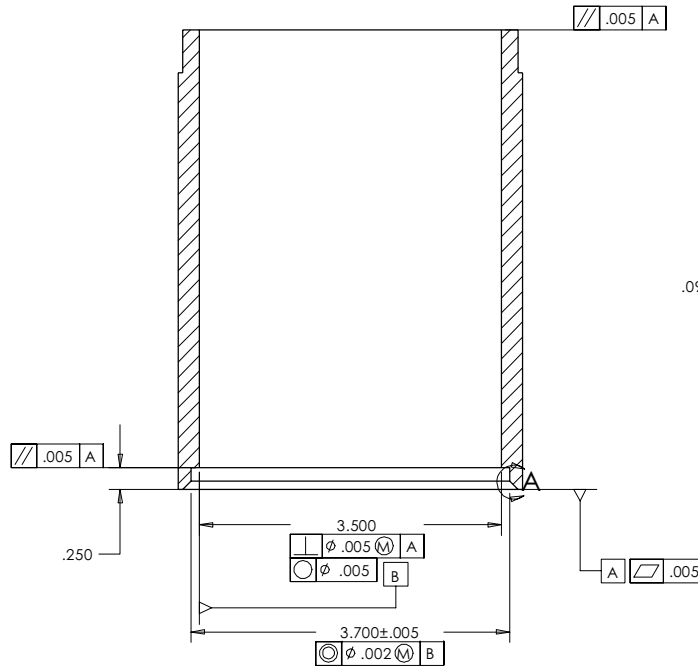

ITEM NO.	REQ. QUANTITY	SPARE	LOT	PART NUMBER	DESCRIPTION	SUPPLIER
1	1				TOP BELLOW SLUG & CAP	

UNLESS OTHERWISE SPECIFIED:				DATE	NAME
DIMENSIONS ARE IN INCHES				4/02	Hardham
TOLERANCES:				DRAWN	5/23/02
.XX ± 0.02"				K em	LAST
.XXX ± 0.001"				CHECKED	5/27/02
ANGULAR ± 30°				K em	HER
MATERIAL				PART NAME	
304 L				TOP BELLOW SLUG & CAP	
FINISH				SIZE DWG. NO.	
				C D020291-03-E	
COMMENTS:				SCALE:	
				SHEET 17 OF 37	