

NOTES: UNLESS OTHERWISE SPECIFIED

1. REMOVE ALL BURRS AND BREAK SHARP EDGES TO A MAXIMUM OF .015
2. PART NUMBER (DRAWING NO., DASH NO., REVISION NO., SERIAL NO.) TO BE CLEARLY MARKED ON THE PART ITSELF
3. PAINT:  
ALL VISIBLE SURFACES  
MEDIUM BLUE SHERWIN WILLIAMS (POLANE (R) T-PLUS POLYURETHANE ENAMEL) #SW-F63TX-L-2822-5864  
PRIME WITH SHERWIN WILLIAMS INDUSTRIAL WASH PRIMER P60G2
4. "OXI SOLV RUST INHIBITOR" TO BE APPLIED PER MFG. INSTRUCTIONS TO ALL UNPAINTED SURFACES.  
BOTH TAPPED AND THRU HOLES WILL BE PLUGGED DURING APPLICATION.

REV.	DATE	DCN #	DRAWING TREE #

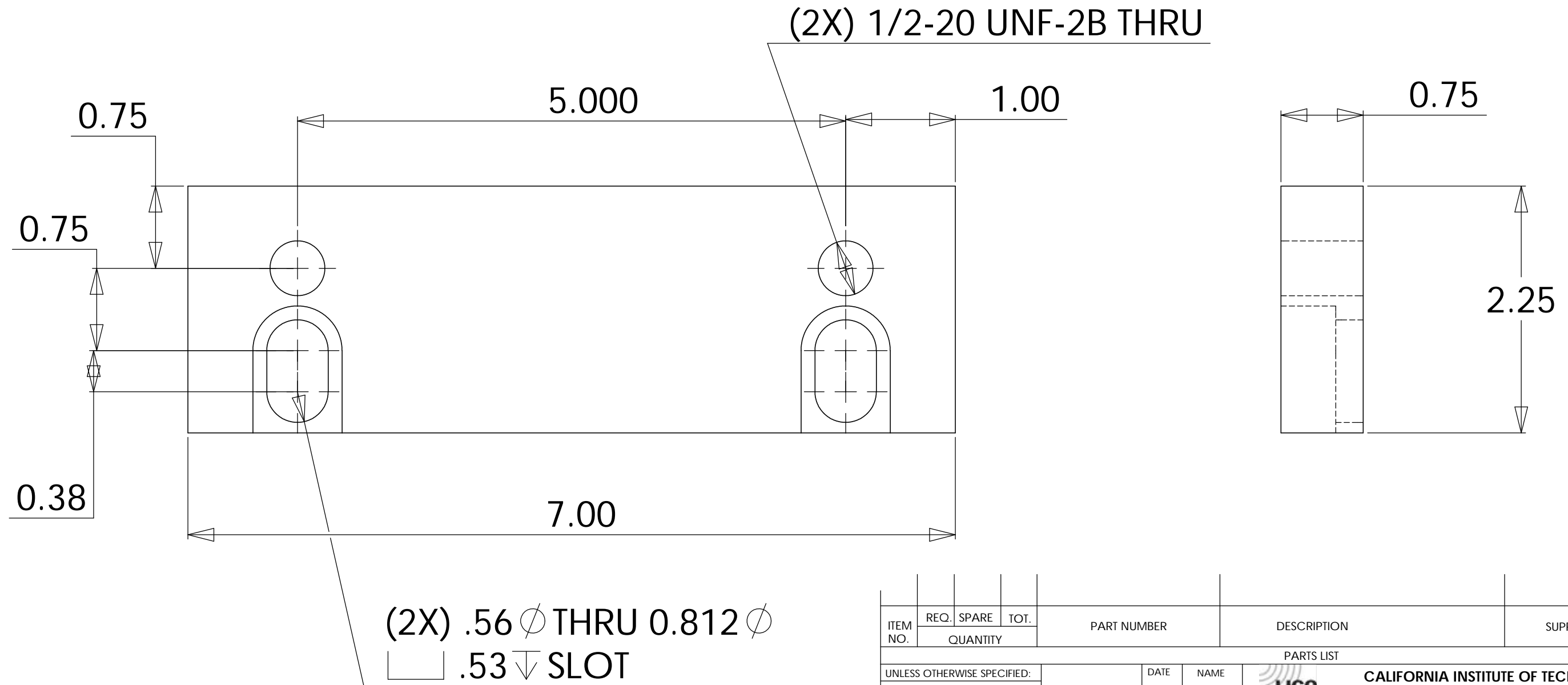

ITEM NO.	REQ.	SPARE	TOT.	PART NUMBER	DESCRIPTION	SUPPLIER
UNLESS OTHERWISE SPECIFIED:						
DIMENSIONS ARE IN INCHES				DRAWN	DATE	NAME
TOLERANCES:				KMASON	6/5/02	
.XX ±: .02				CHECKED		
.XXX ±: .005						
ANGULAR: ± 1 DEG						
MATERIAL				PARTS LIST		
1018 CRS				CALIFORNIA INSTITUTE OF TECHNOLOGY		
FINISH				MASSACHUSETTS INSTITUTE OF TECHNOLOGY		
SEE NOTES				SYSTEM		
				SUB-SYSTEM		
				NEXT ASSY		
				HYDRAULIC PRE-ISOLATOR ASSEMBLY		
				PART NAME		
				LOWER ACTUATOR PLATE		
SIZE		DWG. NO.		REV		
B		D020306-A-D		A		
SCALE: 1:1		D020306-A.SLDPRT		SHEET 1 OF 1		