

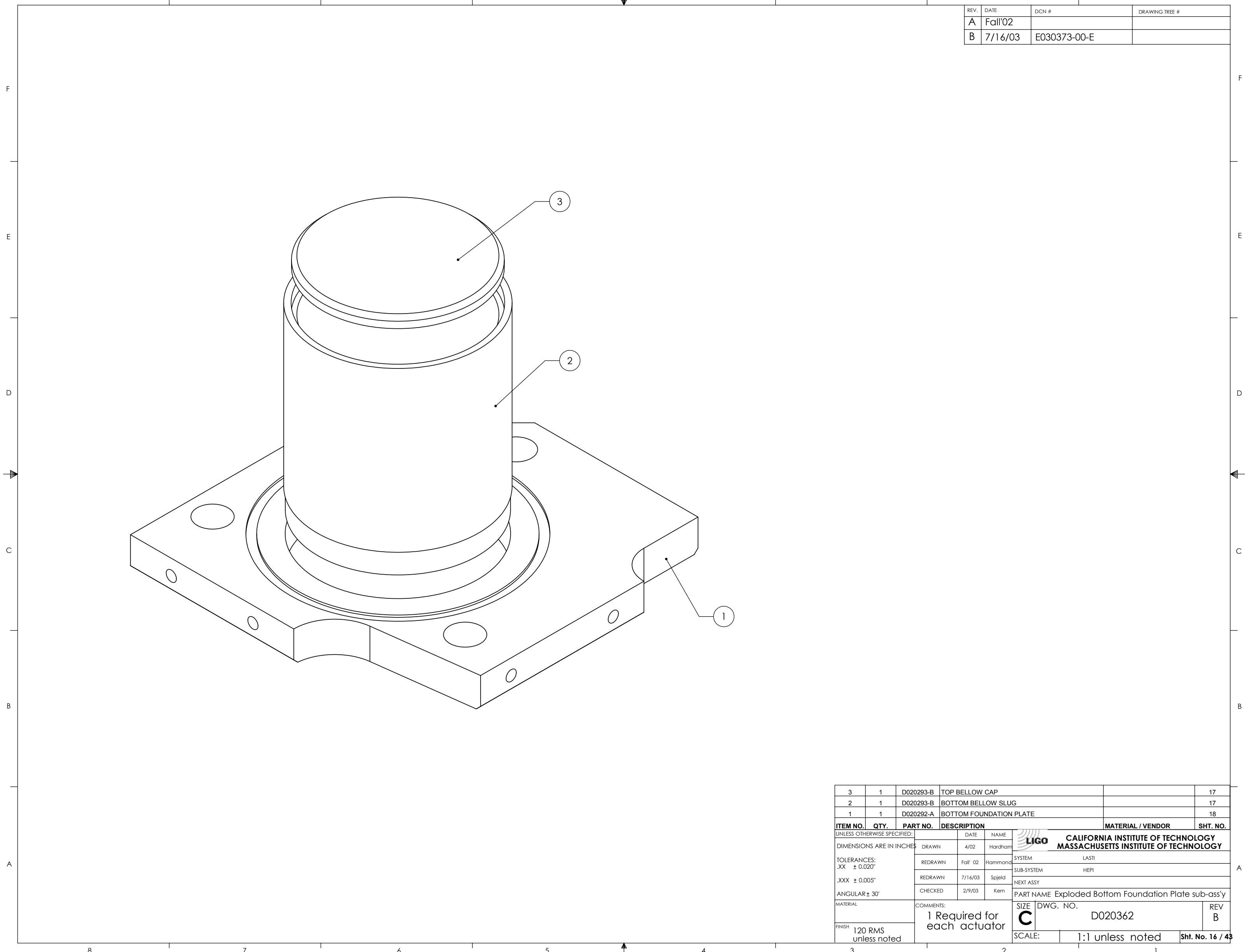

REV.	DATE	DCN #	DRAWING TREE #
A	Fall'02		
B	7/16/03	E030373-00-E	



ITEM NO.	QTY.	PART NO.	DESCRIPTION	MATERIAL / VENDOR	SHT. NO.
3	1	D020293-B	TOP BELLOW CAP		17
2	1	D020293-B	BOTTOM BELLOW SLUG		17
1	1	D020292-A	BOTTOM FOUNDATION PLATE		18

UNLESS OTHERWISE SPECIFIED:		DATE	NAME	 CALIFORNIA INSTITUTE OF TECHNOLOGY MASSACHUSETTS INSTITUTE OF TECHNOLOGY	
DIMENSIONS ARE IN INCHES	DRAWN	4/02	Hardham		
TOLERANCES: .XX ± 0.020"	REDRAWN	Fall' 02	Hammond		
.XXX ± 0.005"	REDRAWN	7/16/03	Spjeld		
ANGULAR ± 30°	CHECKED	2/9/03	Kern	PART NAME Exploded Bottom Foundation Plate sub-ass'y	
MATERIAL	COMMENTS:		SIZE	DWG. NO.	REV
FINISH 120 RMS unless noted	1 Required for each actuator		C	D020362	B
			SCALE:	1:1 unless noted	Sht. No. 16 / 43