

REV.	DATE	DCN #	DRAWING TREE #
A	06/08/04	E030595-00-E	

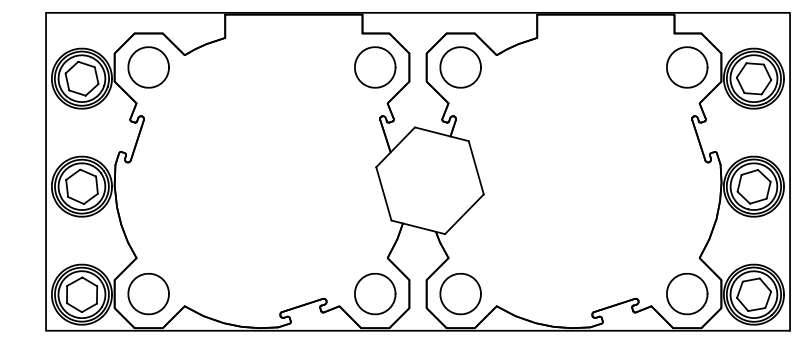
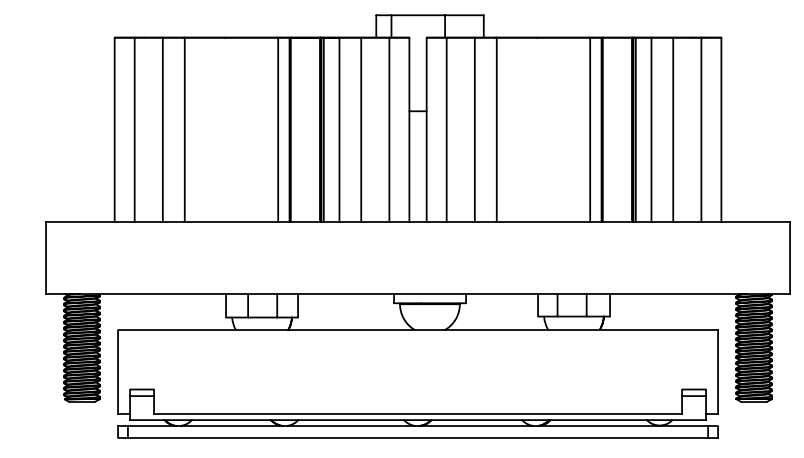
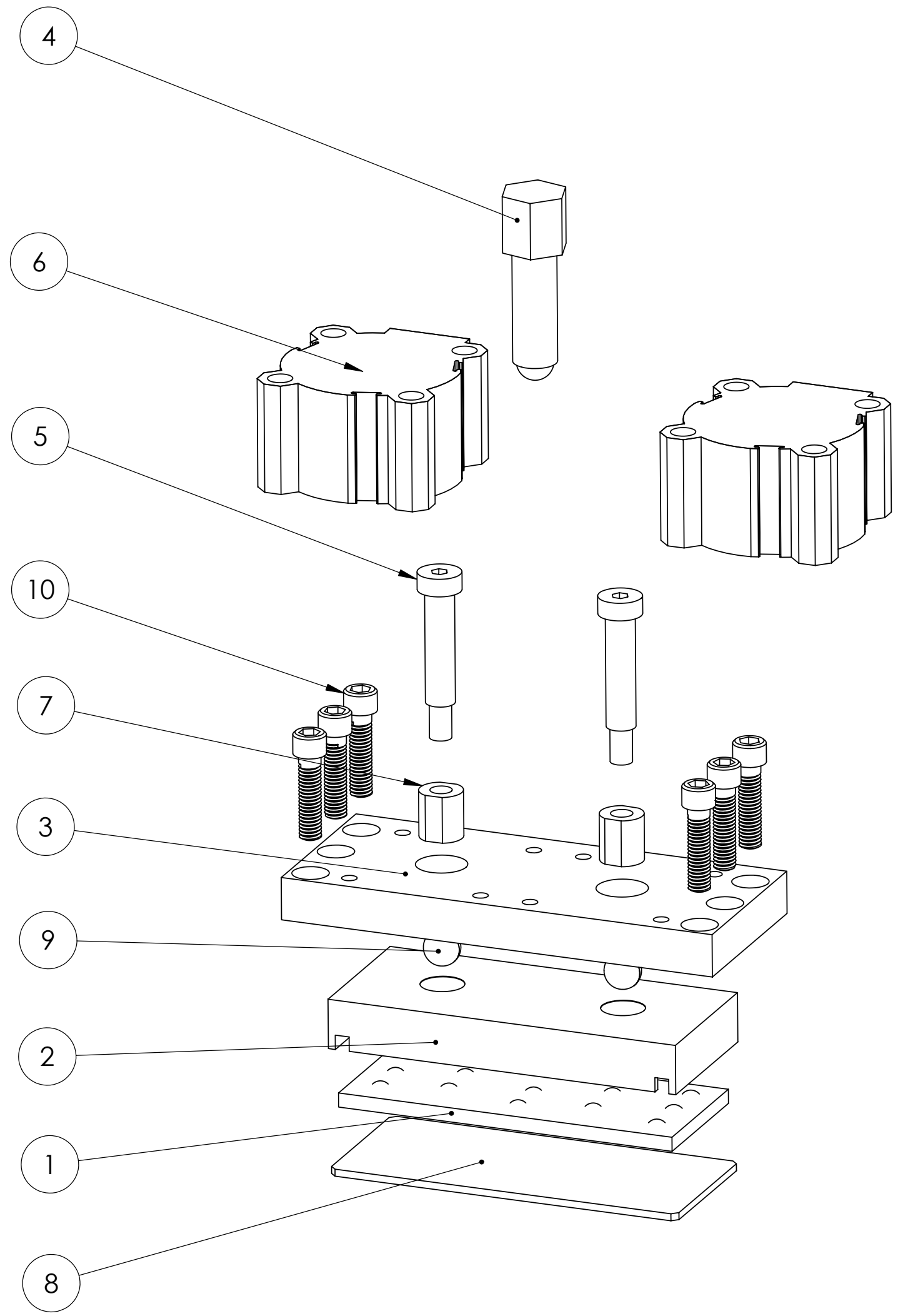

ITEM NO.	QTY.	PART NUMBER	DESCRIPTION	VENDOR
1	1	6821003	Ball Bearing Plate	MSC Ind. Supply
2	1	D020266	Die Roller Plate	Lavallee
3	1	D020265	Support Plate	Lavallee
4	1	-	Power Screw	MIT
5	2	-	Shoulder	MIT
6	2	CRS2U63x3/4-T44	Pneumatic Cylinder	Action Automation
7	2	D020268	Push Rod	Lavallee
8	1	D020267	Shim Plate	Lavallee
9	2	9642K61	5/8 Bearing Ball	McMaster-Carr
10	6	72162 (H-K)	S.H.C.S. 3/8-16 x 1.500	M. J. Vail Company Inc.

PARTS LIST

NOTES: (UNLESS OTHERWISE SPECIFIED)

DIMENSIONS ARE IN INCHES
TOLERANCES:
.XX ± 0.01
.XXX ± 0.005
ANGULAR ± 0.5 °

MATERIAL

FINISH

LIGO CALIFORNIA INSTITUTE OF TECHNOLOGY
MASSACHUSETTS INSTITUTE OF TECHNOLOGY

SYSTEM External Pre-Isolator
SUB-SYSTEM HEPI
NEXT ASSY
PART NAME Pneumatic Bearing Assembly

DRAWN	O.SP.JELD	06.08.04	SIZE	DWG. NO.	D020375	REV.	A
CHECKED			B				
APPROVED				SCALE: 2:1	PROJECTION:		SHEET 1 OF 1