

NOTES CONTINUED:

5. SCRIBE, ENGRAVE, OR MECHANICALLY STAMP (NO INKS OR DYES) DRAWING PART NUMBER, REVISION (AND VARIANT OR "TYPE" IF APPLICABLE) ON NOTED SURFACE OF PART FOLLOWED ON THE NEXT LINE WITH A THREE DIGIT SERIAL NUMBER. SERIAL NUMBERS START AT 101 FOR THE FIRST ARTICLE AND PROCEED CONSECUTIVELY. USE MINIMUM 0.12" HIGH CHARACTERS, UNLESS THE SIZE OF THE PART DICTATES SMALLER CHARACTERS. A VIBRATORY TOOL MAY BE USED.  
EXAMPLE: DXXXXXX-VY, TYPE-XX, S/N XXX

- 6. APPROXIMATE WEIGHT = 0.014 LB.
- 7. MACHINE ALL SURFACES TO REMOVE OXIDES AND MILL FINISH. USE OF ABRASIVE REMOVAL TECHNIQUES IS NOT ALLOWED.
- 8. ALL PARTS SHALL BE MANUFACTURED IN ACCORDANCE WITH LIGO SPECIFICATION E0900364.

REV.	DATE	DCN #	DRAWING TREE #
v1	01 MAR 2011	E0900502	E0900353
-	-	-	-
-	-	-	-

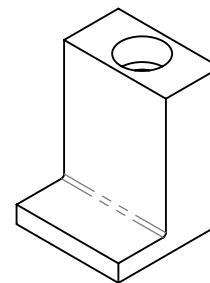
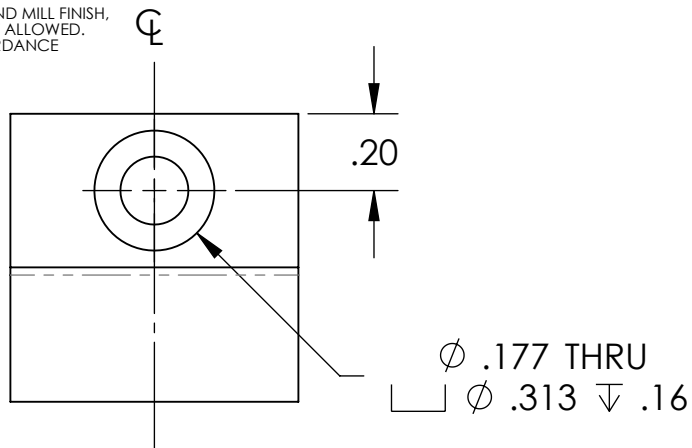

ISOMETRIC VIEW

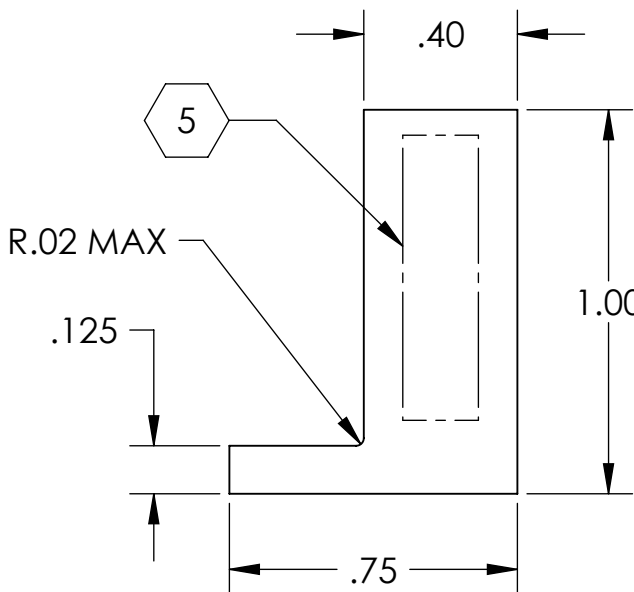
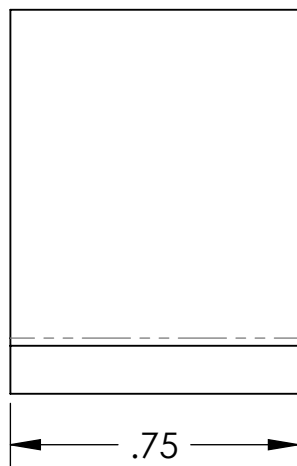

NOTES AND TOLERANCES: (UNLESS OTHERWISE SPECIFIED)

DIMENSIONS ARE IN INCHES

TOLERANCES:

.XX ± .03  
.XXX ± .005

ANGULAR ± 0.2°

- 1. INTERPRET DRAWING PER ASME Y14.5-1994.
- 2. REMOVE ALL SHARP EDGES, .02 MIN.
- 3. DO NOT SCALE FROM DRAWING.
- 4. ALL MACHINING FLUIDS MUST BE FULLY SYNTHETIC, FULLY WATER SOLUBLE AND FREE OF SULFUR, SILICONE, AND CHLORINE.

MATERIAL PFA440 HP (PRESHRUNK) FINISH 63 μinch

**LIGO** CALIFORNIA INSTITUTE OF TECHNOLOGY  
MASSACHUSETTS INSTITUTE OF TECHNOLOGY

SYSTEM ADVANCED LIGO SUB-SYSTEM SUS NEXT ASSY D020427

PART NAME STANDOFF BLOCK FOR HSTS RING FIXTURE

DESIGNER	M. MEYER	22 SEP 2010	SIZE	DWG. NO.	REV.
DRAFTER	B. MOORE	10 OCT 2010	A	D1002342	v1
CHECKER	M. MEYER	12 OCT 2010	SCALE: 2:1	PROJECTION:	SHEET 1 OF 1
APPROVAL					