

LTR		ZONE	DESCRIPTION	REVISIONS									
A			INITIAL RELEASE	DWN	CHK	P-ENG	CONFIG	ME	STRS	MATL	PROJ	QA	RELEASE DATE

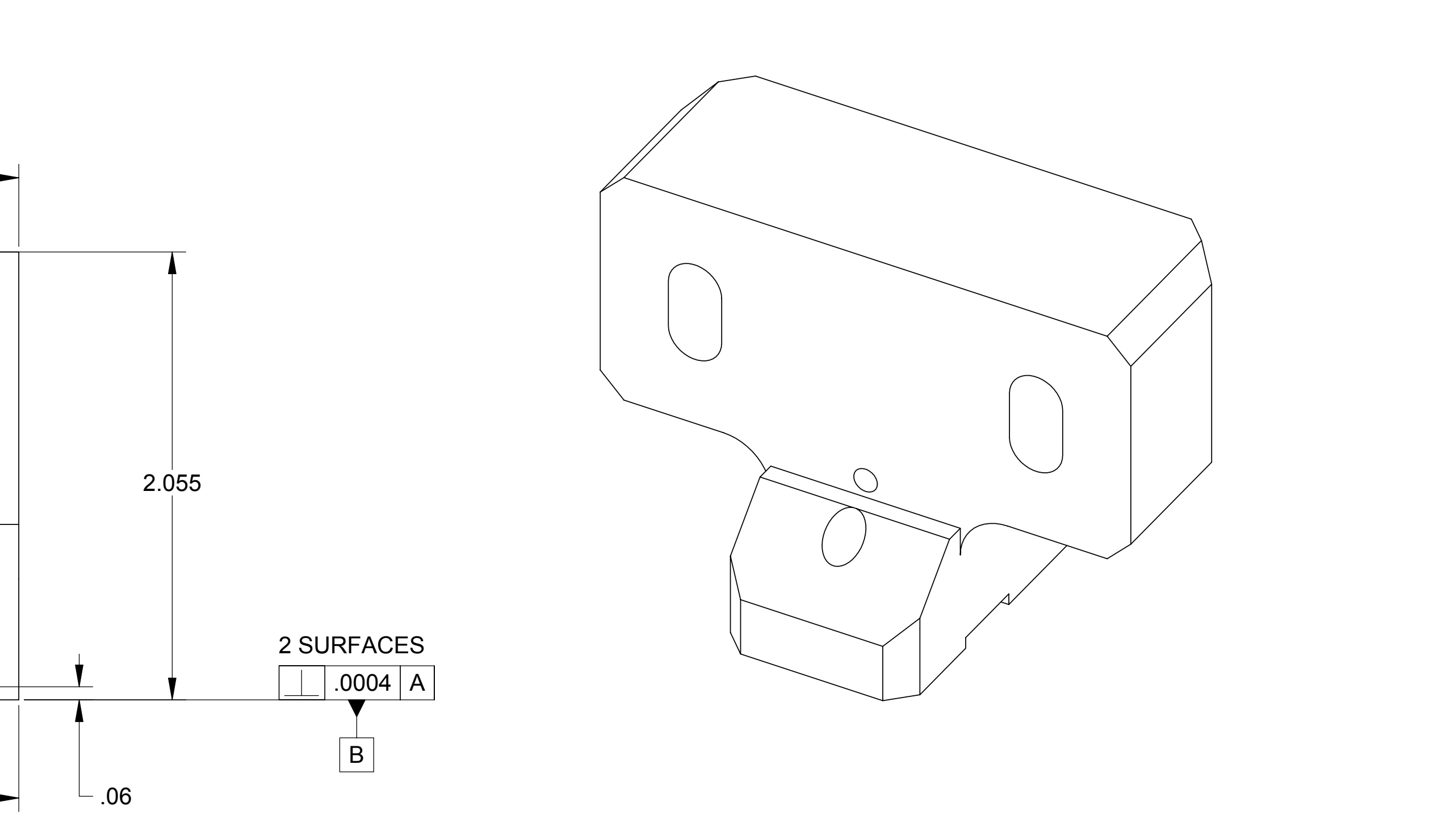
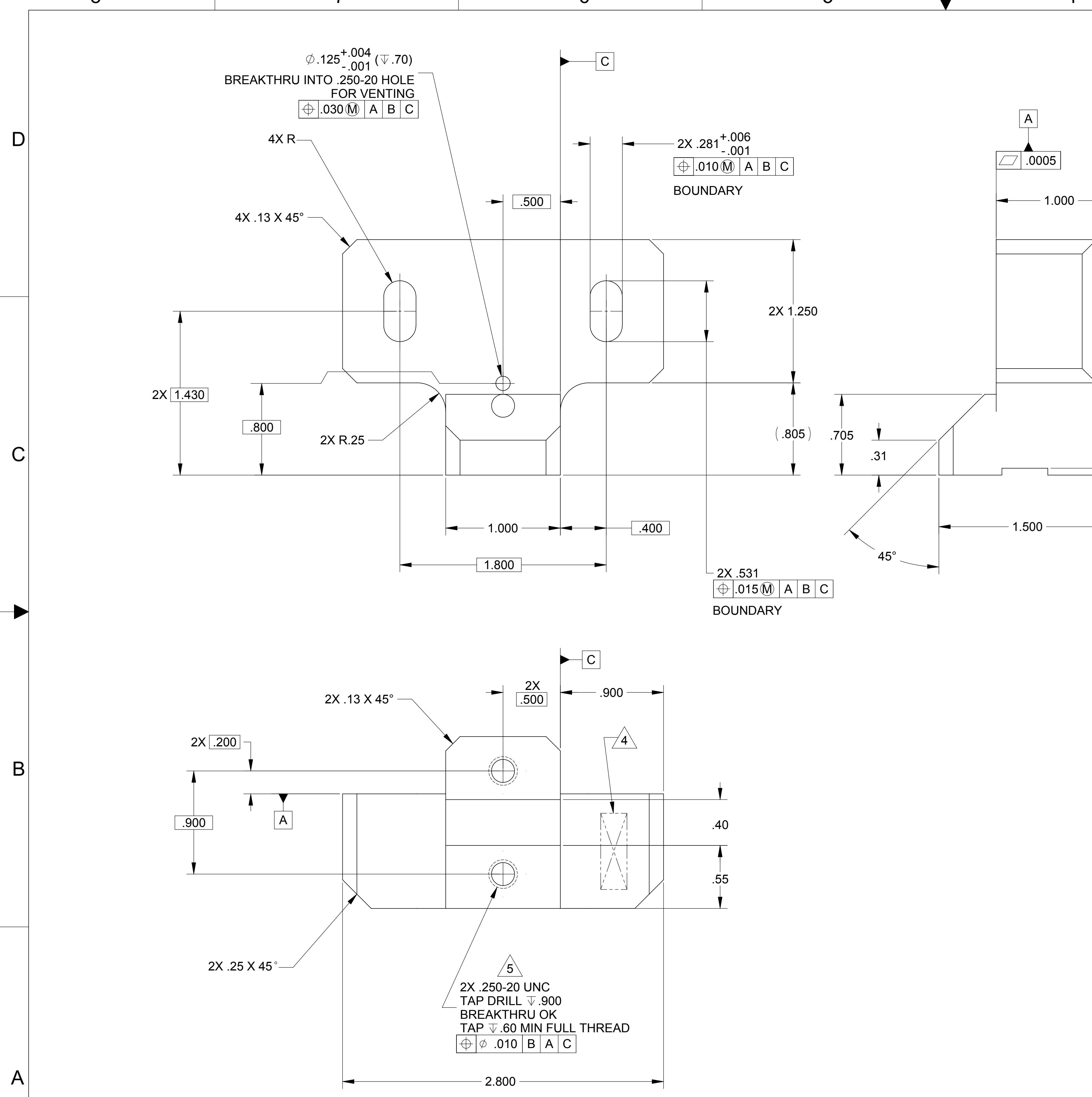

- NOTES: UNLESS OTHERWISE SPECIFIED.
- ALL PARTS SHALL BE MANUFACTURED IN ACCORDANCE WITH ASI SPECIFICATION 20008225 (LIGO E048225).
 - REMOVE ALL BURRS AND SHARP EDGES .005-.015.
 - MACHINE FILLET RADII .003-.015.
 - MARK PART AND SERIAL NUMBER IN LOCATION APPROXIMATELY AS SHOWN USING 0.13-INCH HIGH CHARACTERS IN ACCORDANCE WITH 20006686, TYPE I, CLASSES 4, 5, OR 6. SERIAL NUMBERS START AT 001 FOR FIRST PART AND PROCEED CONSECUTIVELY. PARTS TOO SMALL TO MARK SHALL BE IDENTIFIED IN ACCORDANCE WITH 20006686, TYPE II.
 - THREADED HOLES SHALL BE PRODUCED TO A .004-.006 OVERSIZE CONDITION ON THE PITCH DIAMETER BASED ON A 2B CONDITION. THIS DOES NOT APPLY TO THREADED INSERT HOLES.
 - COUNTERSINK 82° ALL TAPPED HOLES TO MAJOR DIAMETER +.015/-.000.
 - COUNTERSINK 82° ALL DRILLED HOLES .015-.030 DEEP BOTH SIDES.
 - RECORD WEIGHT TO NEAREST 0.1 LB ON INSPECTION REPORT AFTER FINAL MACHINING. ESTIMATED WEIGHT IS .4 LBS.

THIS DOCUMENT MAY CONTAIN ITAR CONTROLLED INFORMATION AND/OR COMMERCE CONTROLLED INFORMATION EXPORT RESTRICTIONS MAY APPLY

FILE ATTACHMENTS

 20007923.x_t

QTY REQD		ITEM NO	REF DES	CAGE NO	PART OR IDENTIFYING NO	NOMENCLATURE OR DESCRIPTION	SPECIFICATION	MATERIAL OR NOTE	ZONE
20007923-1									
PARTS LIST									
CONTRACT NO		UNLESS OTHERWISE SPECIFIED DIMENSIONS ARE IN INCHES		TOLERANCES		ALLIANCE SPACESYSTEMS, INC. 1250 Lincoln Ave., Suite 100 Pasadena, CA 91103		BRACKET, STAGE 1-2 HORZ ACTUATOR COIL ADPT LIGO-D047923-A	
		DECIMALS .XX ±.03 .XXX ±.010 ± 1/2"		ANGLES 125					
		MACHINE FINISH		DO NOT SCALE DRAWING INTERPRET DWG PER ASME Y14.5M-1994		DWN R.D.BILLING 07/07/04		SIZE D CAGE CODE 1KNU9 20007923 REV A	
20007970		1388		AL 6061-T651 AMS-QQ-A-250/11		PROJ ENGR		SCALE 2:1 UNCLASSIFIED SHEET 1 OF 1	
NEXT ASSEMBLY		PROJECT CODE		MATERIAL		CHK		REV 7/04	
APPLICATION						STRS			
						ME			