

8

7

6

5

4

3

2

1

LTR		ZONE		REVISIONS												DWN	CHK	ENGR	STRESS	MATL	THRM	ME	PROJ	QA	RELEASE DATE
A				INITIAL RELEASE																					

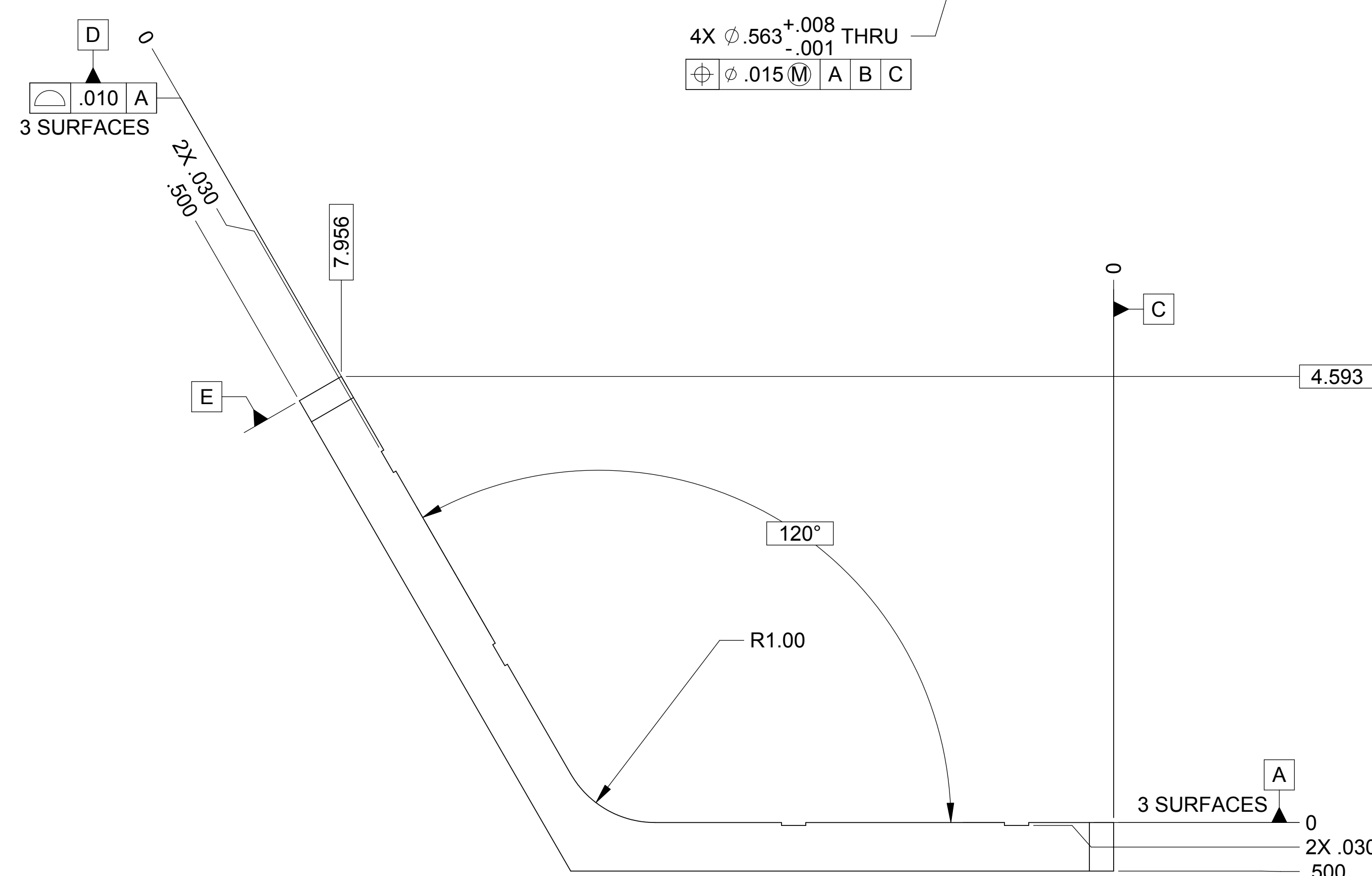
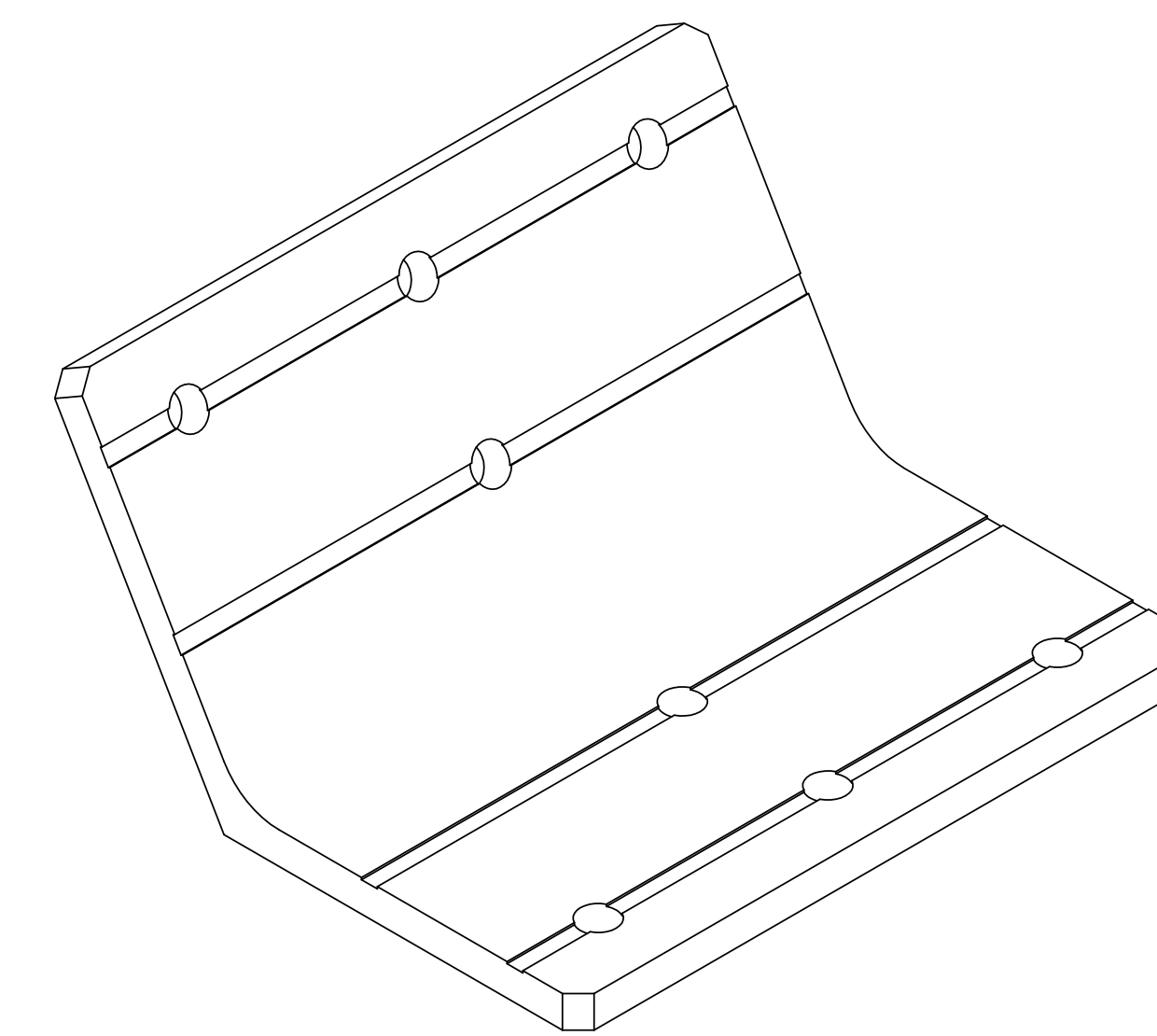
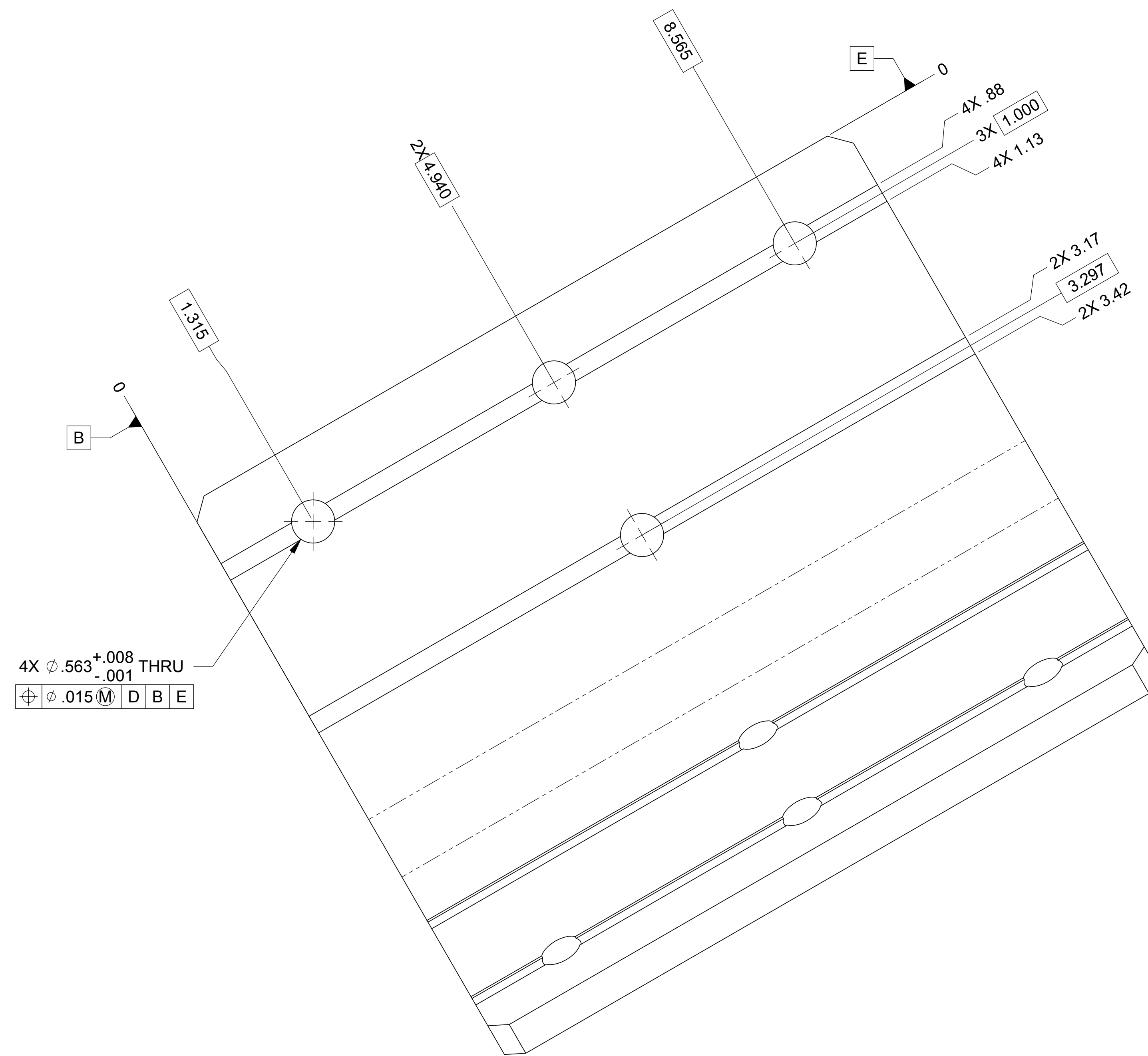
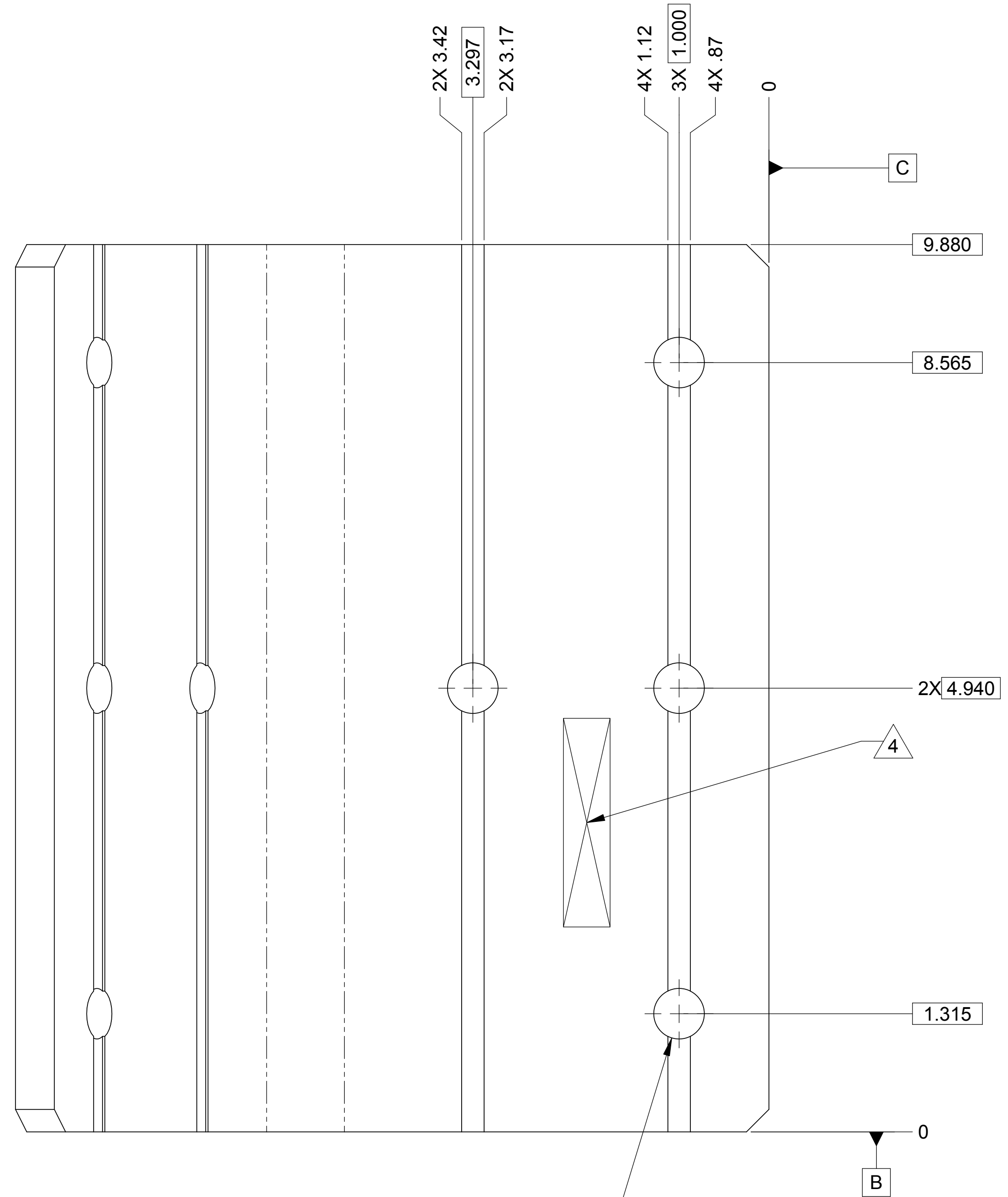

- NOTES: UNLESS OTHERWISE SPECIFIED.
- ALL PARTS SHALL BE MANUFACTURED IN ACCORDANCE WITH ASI SPECIFICATION 20008225 (LIGO E048225).
 - REMOVE ALL BURRS AND SHARP EDGES .005-.015.
 - MACHINE FILLET RADII .003-.015.
 - MARK PART AND SERIAL NUMBER IN LOCATION APPROXIMATELY AS SHOWN USING 0.13-INCH HIGH CHARACTERS IN ACCORDANCE WITH 20006686, TYPE I, CLASSES 4, 5, OR 6. SERIAL NUMBERS START AT 001 FOR FIRST PART AND PROCEED CONSECUTIVELY. PARTS TOO SMALL TO MARK SHALL BE IDENTIFIED IN ACCORDANCE WITH 20006686, TYPE II.
 - COUNTERSINK 82° ALL DRILLED HOLES .015-.030 DEEP BOTH SIDES.
 - RECORD WEIGHT TO NEAREST 0.1 LB ON INSPECTION REPORT AFTER FINAL MACHINING. ESTIMATED WEIGHT PER DASH NUMBER IS: 20007956-1=5.2 LBS
 - THIS PART IS TO BE PRODUCED USING THE CAD MODEL. IF THERE ARE DISCREPANCIES BETWEEN THIS DRAWING AND THE MODEL DATABASE THE MODEL DATABASE WILL TAKE PRECEDENCE.

20007956-1		PART OR IDENTIFYING NO		NOMENCLATURE OR DESCRIPTION		SPECIFICATION	MATERIAL OR NOTE	ZONE	
QTY	REGD	ITEM NO	REF DES	CAGE NO	PART OR IDENTIFYING NO	NOMENCLATURE OR DESCRIPTION	SPECIFICATION	MATERIAL OR NOTE	ZONE
CONTRACT NO		UNLESS OTHERWISE SPECIFIED DIMENSIONS ARE IN INCHES		PARTS LIST		<p>RELEASED DATE: 08/16/04</p> <p>ALLIANCE SPACESYSTEMS, INC. 1250 Lincoln Ave., Suite 100 Pasadena, CA 91103</p> <p>asi</p> <p>CORNER CLIP, OUTER STAGE 0 LIGO-D047956-A</p>			
MATERIAL		MACHINE FINISH		DWN R.D.BILLING		<p>SIZE: E</p> <p>CAGE CODE: 1KNU9</p> <p>SCALE: 1:1</p>			
NEXT ASSEMBLY		MATERIAL		DWN R.D.BILLING		<p>20007890</p> <p>1388</p> <p>AL 6061-T651</p> <p>AMS-QQ-A-250/11</p> <p>08/16/04</p> <p>20007956</p>			
APPLICATION		MATERIAL		DWN R.D.BILLING		<p>UNCLASSIFIED</p> <p>SHEET 1 OF 1</p>			

8

7

6

5

4

3

2

1

REV 704