

LTR		ZONE		DESCRIPTION	REVISIONS									
					DWN	CHK	ENGR	STRESS	MATL	THRM	ME	PROJ	QA	RELEASE DATE
A				INITIAL RELEASE										

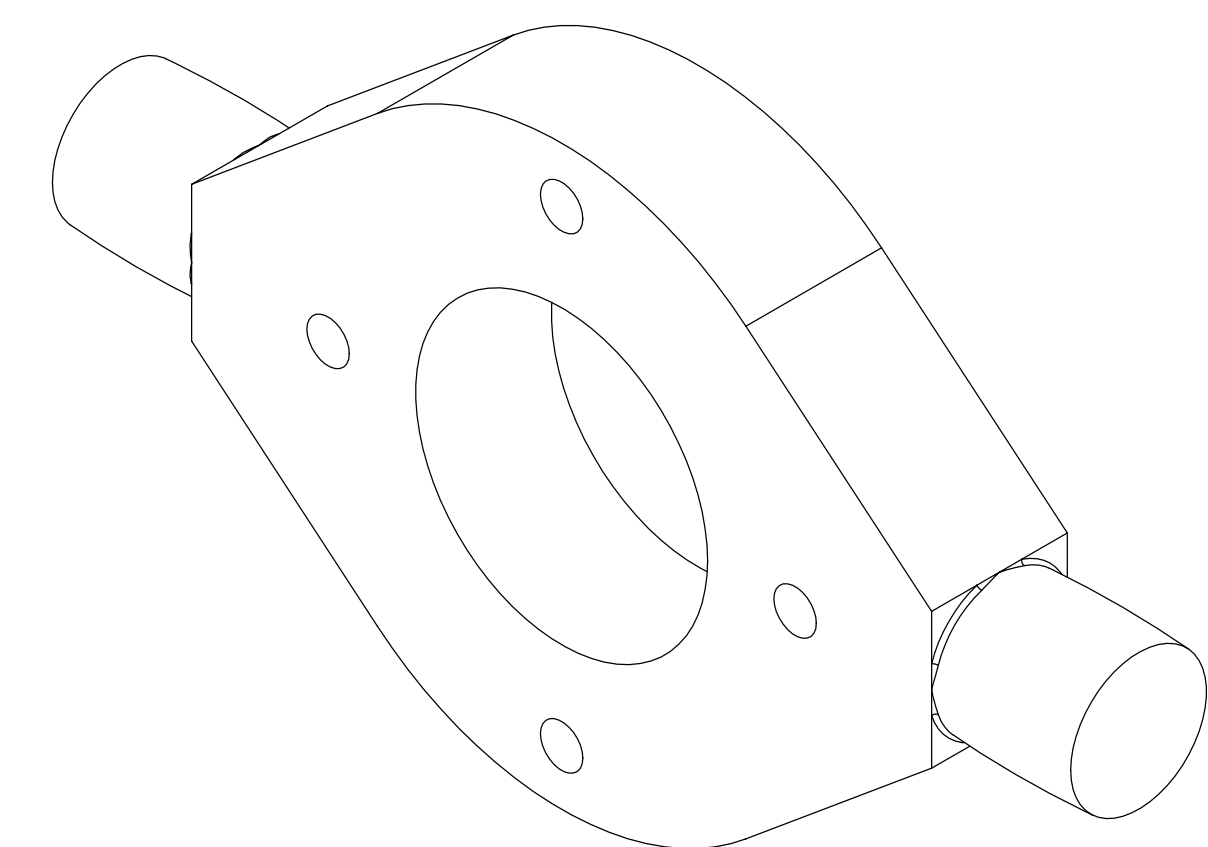

ISOMETRIC VIEW FOR REFERENCE ONLY

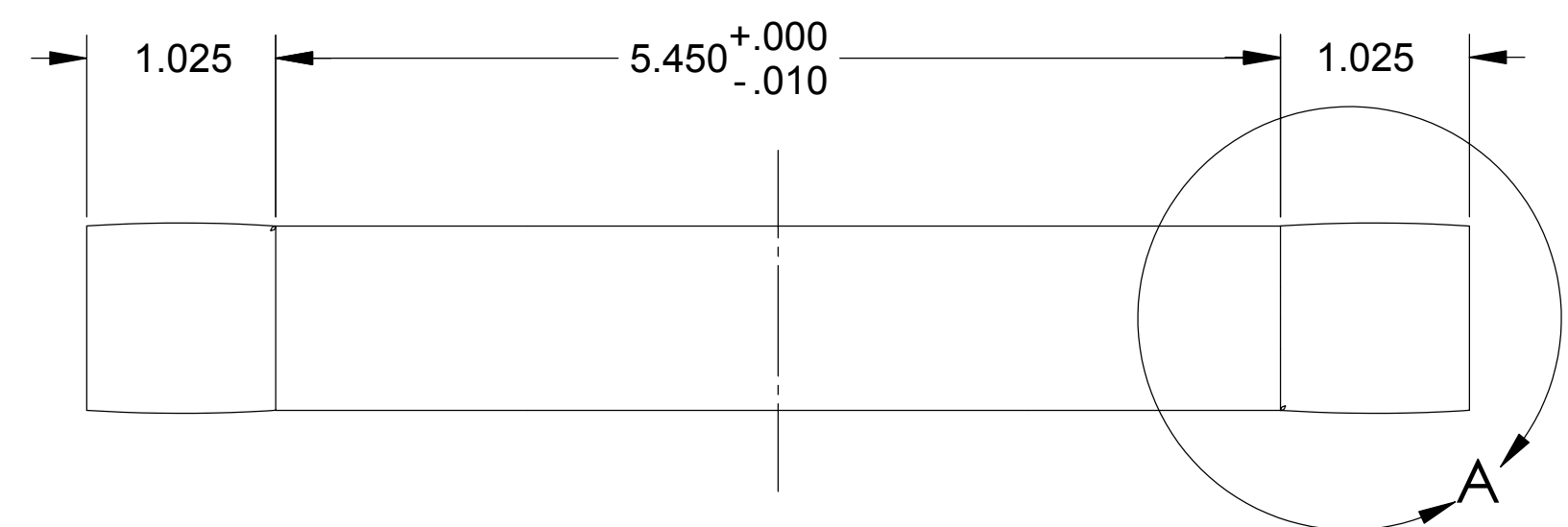
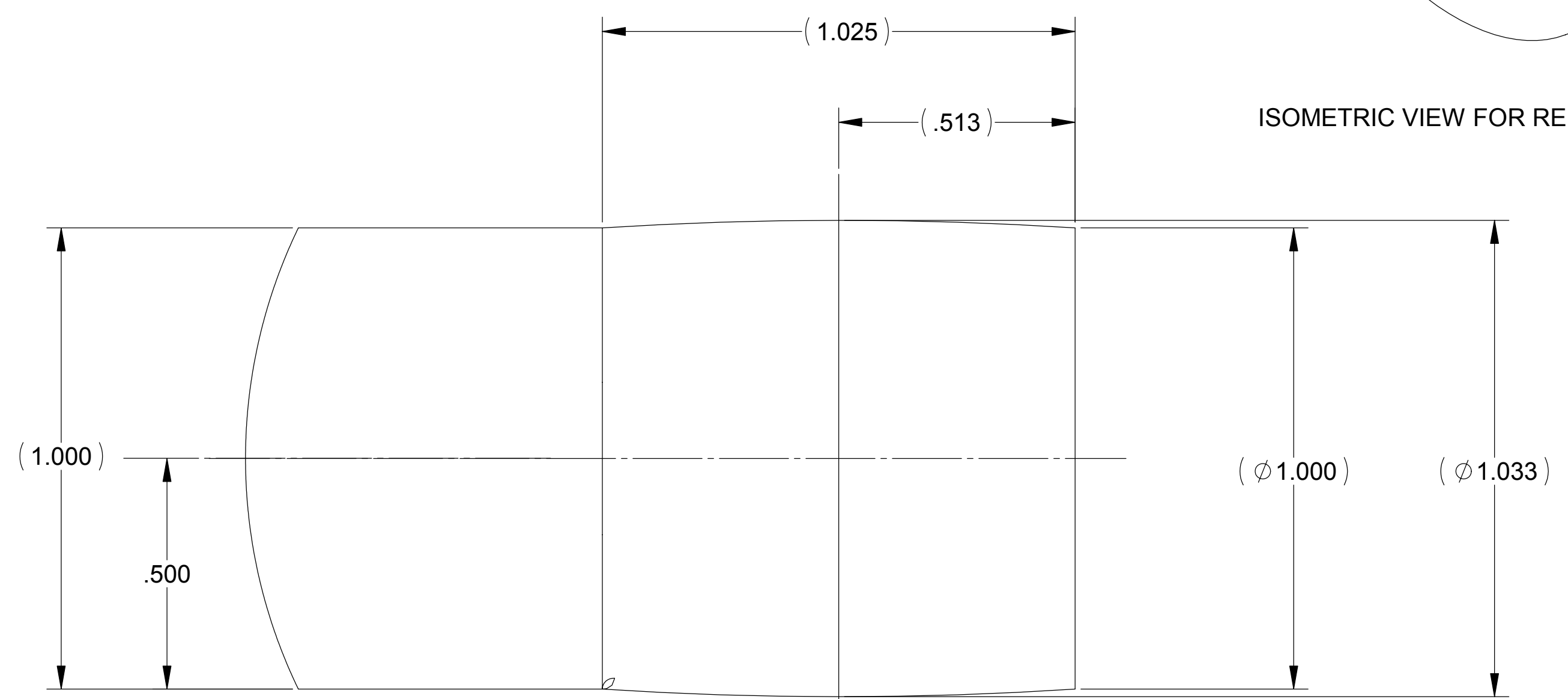
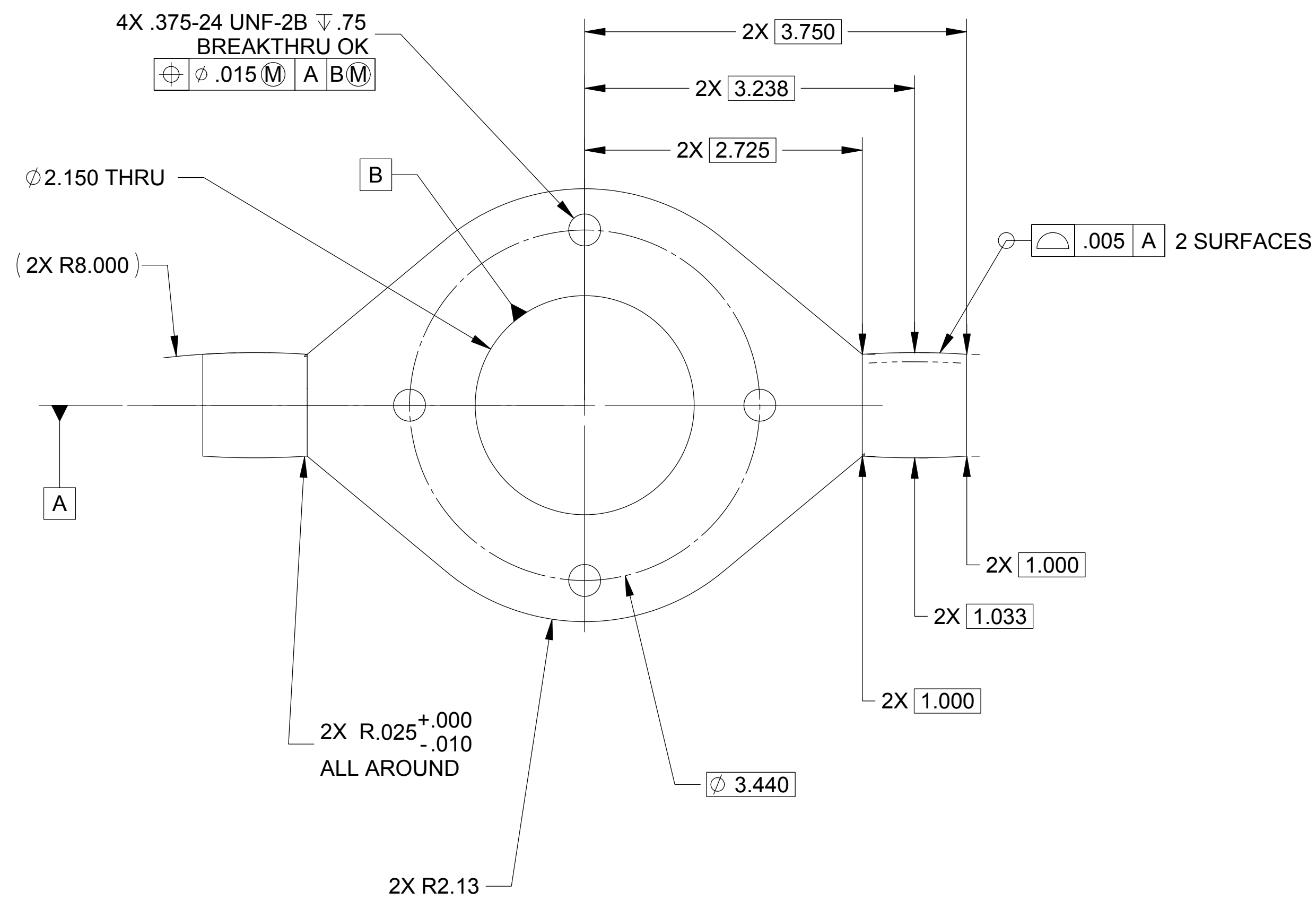

DETAIL A
SCALE 4 : 1
2 PLACES

- NOTES: UNLESS OTHERWISE SPECIFIED.
1. REMOVE ALL BURRS AND SHARP EDGES .005-.015.
 2. MACHINE FILLET RADII .003-.015.
 3. MACHINING CENTERS PERMISSIBLE.

QTY REQD		ITEM NO	REF DES	CAGE NO	20008063-1	PART OR IDENTIFYING NO	NOMENCLATURE OR DESCRIPTION	SPECIFICATION	MATERIAL OR NOTE	ZONE																																	
CONTRACT NO																																											
UNLESS OTHERWISE SPECIFIED DIMENSIONS ARE IN INCHES TOLERANCES DECIMALS .XX ±.03 .XXX ±.010 ±.1/2" ANGLES 63° MACHINE FINISH DO NOT SCALE DRAWING INTERPRET DWG PER ASME Y14.5M-1994																																											
MATERIAL CRES 17-4 PH OR 4130																																											
PARTS LIST																																											
<table border="1"> <tr> <td>DWN</td> <td>J. LARAMEE</td> <td>07/27/04</td> </tr> <tr> <td>PROJ ENGR</td> <td></td> <td></td> </tr> <tr> <td>CHK</td> <td></td> <td></td> </tr> <tr> <td>CONFIG</td> <td></td> <td></td> </tr> <tr> <td>ME</td> <td></td> <td></td> </tr> </table>											DWN	J. LARAMEE	07/27/04	PROJ ENGR			CHK			CONFIG			ME																				
DWN	J. LARAMEE	07/27/04																																									
PROJ ENGR																																											
CHK																																											
CONFIG																																											
ME																																											
<table border="1"> <tr> <td>20008050</td> <td>1388</td> <td></td> <td></td> <td></td> <td></td> <td></td> <td></td> <td></td> <td></td> <td></td> </tr> <tr> <td>NEXT ASSEMBLY</td> <td>PROJECT CODE</td> <td></td> <td></td> <td></td> <td></td> <td></td> <td></td> <td></td> <td></td> <td></td> </tr> <tr> <td colspan="11">APPLICATION</td> </tr> </table>											20008050	1388										NEXT ASSEMBLY	PROJECT CODE										APPLICATION										
20008050	1388																																										
NEXT ASSEMBLY	PROJECT CODE																																										
APPLICATION																																											
<table border="1"> <tr> <td>SIZE</td> <td>D</td> <td>CAGE CODE</td> <td>1KNU9</td> <td>20008063</td> <td>REV</td> <td>A</td> </tr> <tr> <td colspan="3">SCALE 1:1</td> <td>UNCLASSIFIED</td> <td colspan="3">SHEET 1 OF 1</td> </tr> </table>											SIZE	D	CAGE CODE	1KNU9	20008063	REV	A	SCALE 1:1			UNCLASSIFIED	SHEET 1 OF 1																					
SIZE	D	CAGE CODE	1KNU9	20008063	REV	A																																					
SCALE 1:1			UNCLASSIFIED	SHEET 1 OF 1																																							
<table border="1"> <tr> <td colspan="2">ALLIANCE SPACESYSTEMS, INC.</td> <td colspan="9">1250 Lincoln Ave., Suite 100 Pasadena, CA 91103</td> </tr> <tr> <td colspan="2">MOUNT, ACME NUT - CRADLE</td> <td colspan="9">SPRING TEST FIXTURE</td> </tr> <tr> <td colspan="2">LIGO D048063-A</td> <td colspan="9"></td> </tr> </table>											ALLIANCE SPACESYSTEMS, INC.		1250 Lincoln Ave., Suite 100 Pasadena, CA 91103									MOUNT, ACME NUT - CRADLE		SPRING TEST FIXTURE									LIGO D048063-A										
ALLIANCE SPACESYSTEMS, INC.		1250 Lincoln Ave., Suite 100 Pasadena, CA 91103																																									
MOUNT, ACME NUT - CRADLE		SPRING TEST FIXTURE																																									
LIGO D048063-A																																											

THIS DOCUMENT MAY CONTAIN ITAR CONTROLLED INFORMATION AND/OR COMMERCE CONTROLLED INFORMATION EXPORT RESTRICTIONS MAY APPLY

FILE ATTACHMENTS
20008063.x_t