

		REVISIONS																		
LTR	ZONE	DESCRIPTION								DWN	CHK	ENGR	STRESS	MATL	THRM	ME	PROJ	QA	RELEASE DATE	
A		INITIAL RELEASE																		

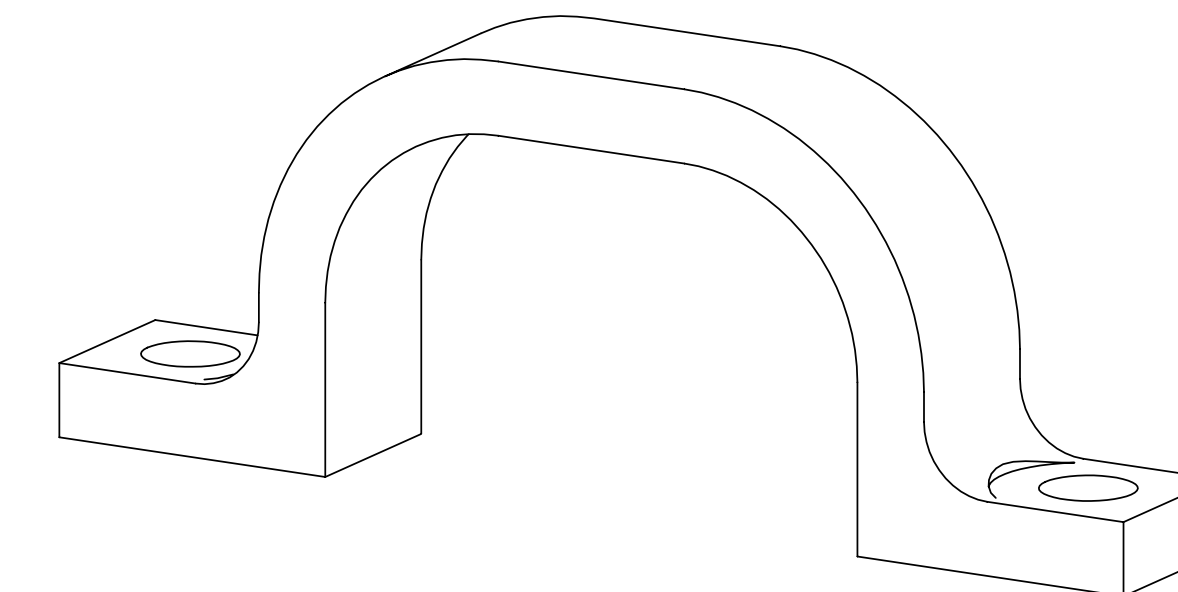

ISOMETRIC VIEW FOR REFERENCE ONLY

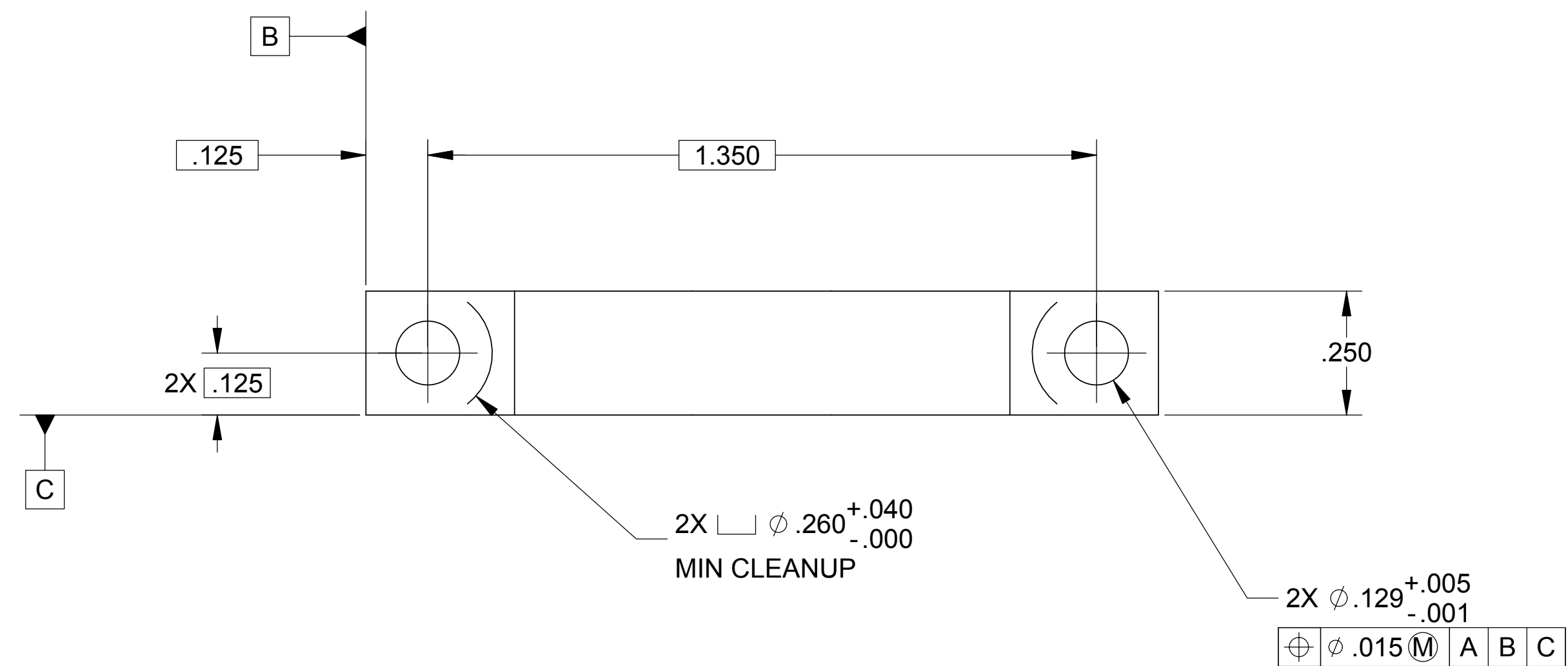
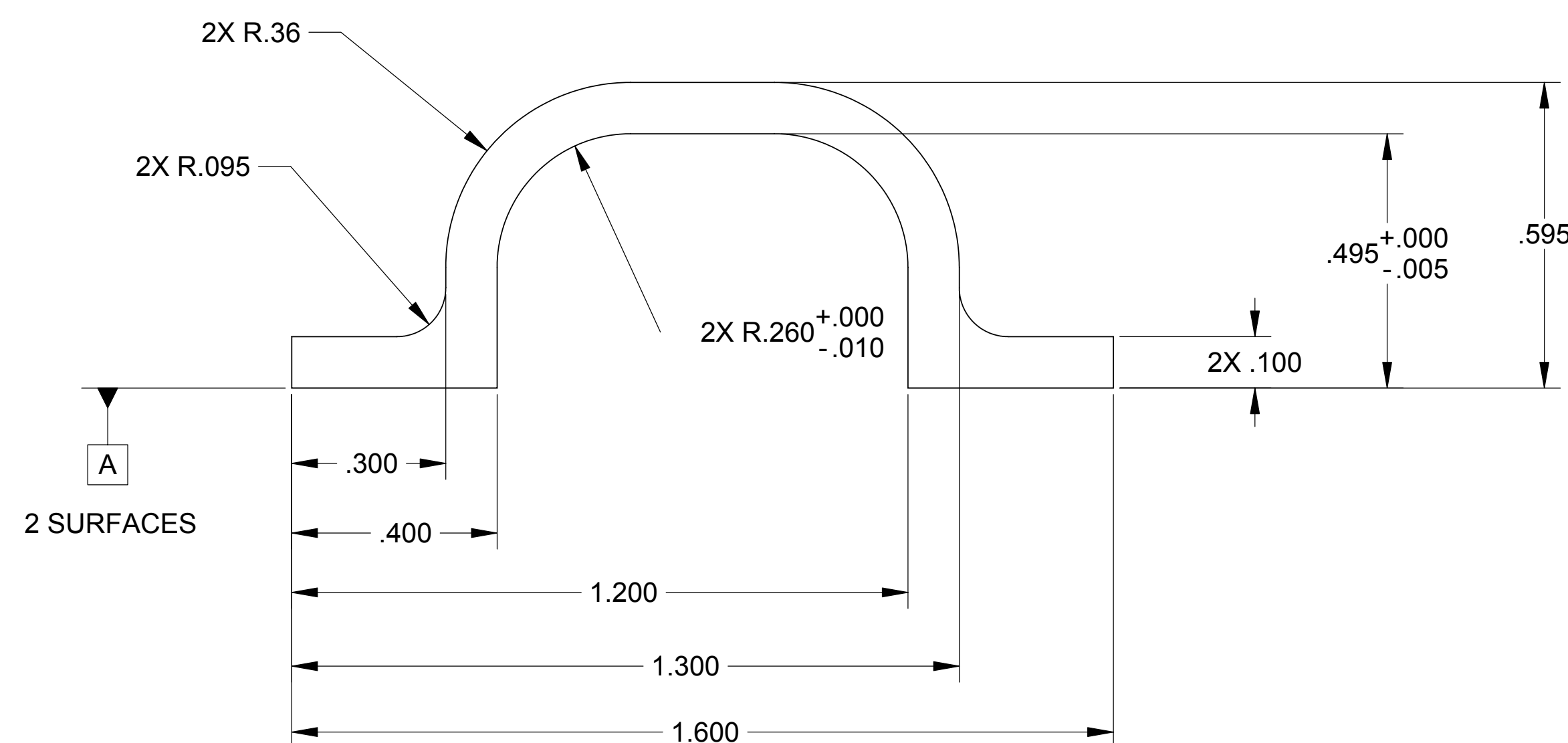

2. MACHINE FILLET RADII .005 - .015.
 1. REMOVE ALL BURRS AND SHARP EDGES .005 - .015.
 NOTES: UNLESS OTHERWISE SPECIFIED

THIS DOCUMENT MAY CONTAIN ITAR CONTROLLED INFORMATION AND/OR COMMERCE CONTROLLED INFORMATION EXPORT RESTRICTIONS MAY APPLY

FILE ATTACHMENTS

 clamp_motor_mount.x_t

		20008589-1									
QTY REQD	ITEM NO	REF DES	CAGE NO	PART OR IDENTIFYING NO	NOMENCLATURE OR DESCRIPTION	SPECIFICATION	MATERIAL OR NOTE	ZONE			
					PARTS LIST						
CONTRACT NO					UNLESS OTHERWISE SPECIFIED DIMENSIONS ARE IN INCHES TOLERANCES DECIMALS .XX ±.03 .XXX ±.010 ANGLES ± 1/2° MACHINE FINISH 63 DO NOT SCALE DRAWING INTERPRET DWG PER ASME Y14.5M		ALLIANCE SPACESYSTEMS, INC. 1250 Lincoln Ave., Suite 100 Pasadena, CA 91103		RELEASED 5/19/2004		
20008593					ALUMINUM 7075-T7351 AMS-QQ-A-250/12		DWN J. LARAMEE 04/28/04 ENGR NA STRS NA CHK NA MATL NA THRM NA PROJ NA ME NA QA NA		SCALE 4:1		
NEXT ASSEMBLY PROJECT CODE					APPLICATION		SIZE D CAGE CODE 1KNU9 20008589		REV A SHEET 1 OF 1		