

LTR		ZONE		DESCRIPTION		REVISIONS										
DWN	CHK	P-ENG	CONFIG	ME	STRS	MATL	PROJ	QA	RELEASE DATE							
A																

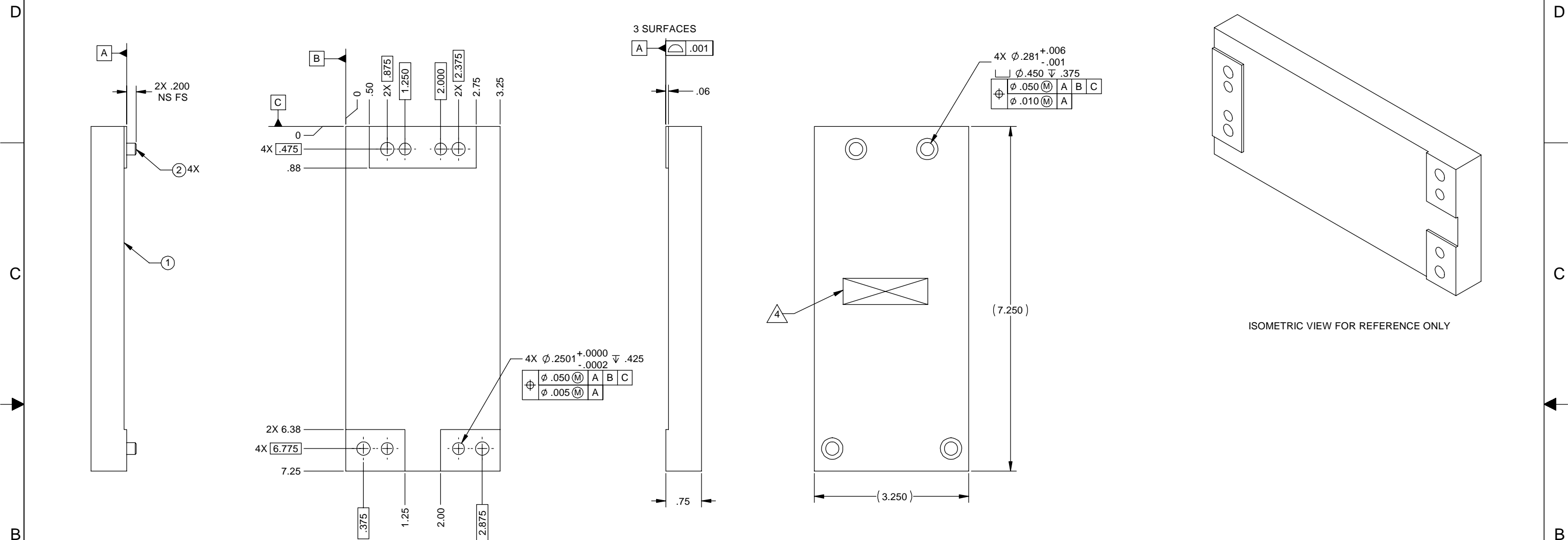

- NOTES: UNLESS OTHERWISE SPECIFIED.
- ALL PARTS SHALL BE MANUFACTURED IN ACCORDANCE WITH ASI SPECIFICATION 20008225 (LIGO E048225).
  - REMOVE ALL BURRS AND SHARP EDGES .005-.015.
  - MACHINE FILLET RADII .003-.015.
  - MARK PART AND SERIAL NUMBER IN LOCATION APPROXIMATELY AS SHOWN USING 0.13-INCH HIGH CHARACTERS IN ACCORDANCE WITH 20006686, TYPE I, CLASSES 4, 5, OR 6. SERIAL NUMBERS START AT 001 FOR FIRST PART AND PROCEED CONSECUTIVELY. PARTS TOO SMALL TO MARK SHALL BE IDENTIFIED IN ACCORDANCE WITH 20006686, TYPE II.
  - COUNTERSINK 82° ALL DRILLED HOLES .015-.030 DEEP BOTH SIDES.

4	2			McMASTER CARR P/N 98380A539	PIN $\phi$ .250 X .625 L		CRES	
1	1			2000XXXX-1	STAGE 1-2 HORI ACTUATOR SETUP TOOLING, BASEPLATE			
-1	ITEM NO	REF DES	CAGE NO	PART OR IDENTIFYING NO	NOMENCLATURE OR DESCRIPTION	SPECIFICATION	MATERIAL OR NOTE	ZONE

CONTRACT NO		UNLESS OTHERWISE SPECIFIED		THIS DRAWING IS PRELIMINARY AND NOT UNDER CONFIGURATION CONTROL UNLESS A RED RELEASED STAMP APPEARS HERE.		PARTS LIST	
		DIMENSIONS ARE IN INCHES					
		TOLERANCES					
		DECIMALS .XX $\pm$ .03		ANGLES $\pm$ 1/2°			
		MACHINE FINISH 63		DO NOT SCALE DRAWING INTERPRET DWG PER ASME Y14.5M-1994			
		MATERIAL AL 6061-T651 AMS-QQ-A-250/11		DWN J. LARAMEE 10/07/04		STAGE 1-2 HORI ACTUATOR SETUP TOOLING, BASEPLATE LIGO D04XXXX-A	
		NEXT ASSEMBLY 1388 PROJECT CODE		CHK MATL		SIZE D CAGE CODE 1KNU9 D050347-00-D REV 0	
		APPLICATION		CONFIG PROJ		SCALE 1:1 SHEET 1 OF 1	

THIS DOCUMENT MAY CONTAIN ITAR CONTROLLED INFORMATION AND/OR COMMERCE CONTROLLED INFORMATION EXPORT RESTRICTIONS MAY APPLY