

26

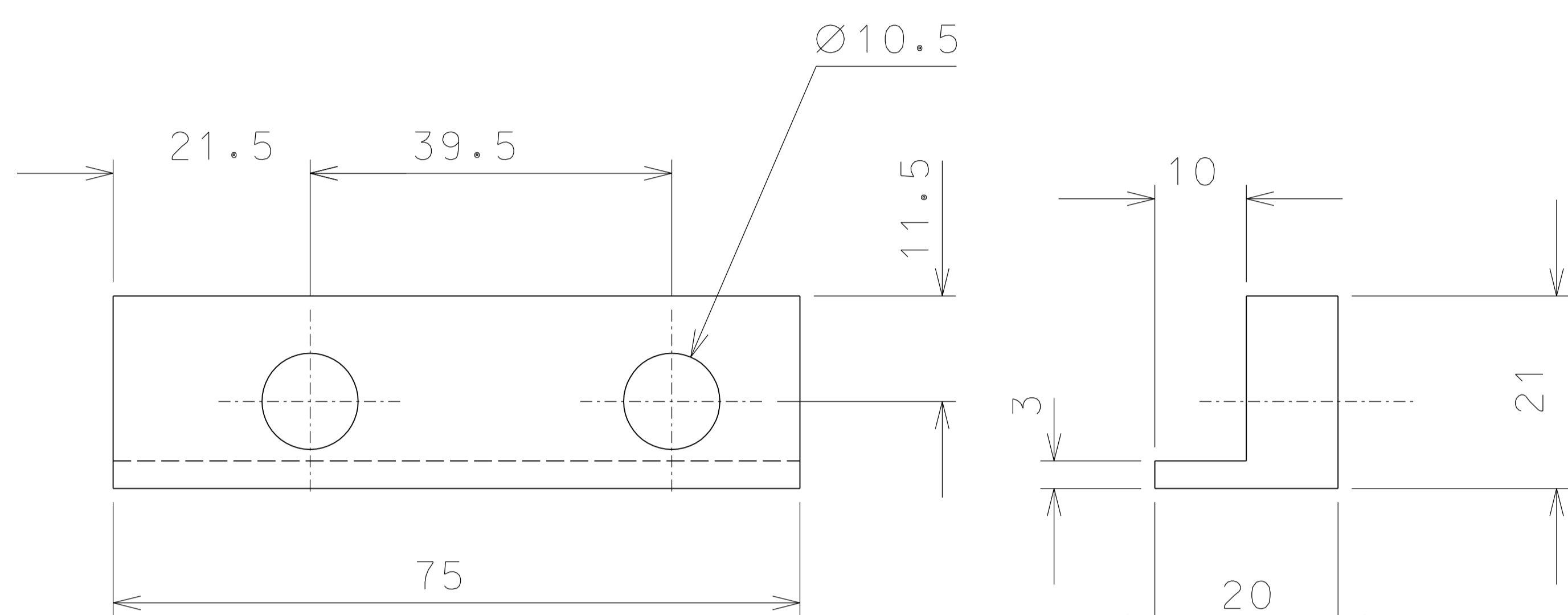

27

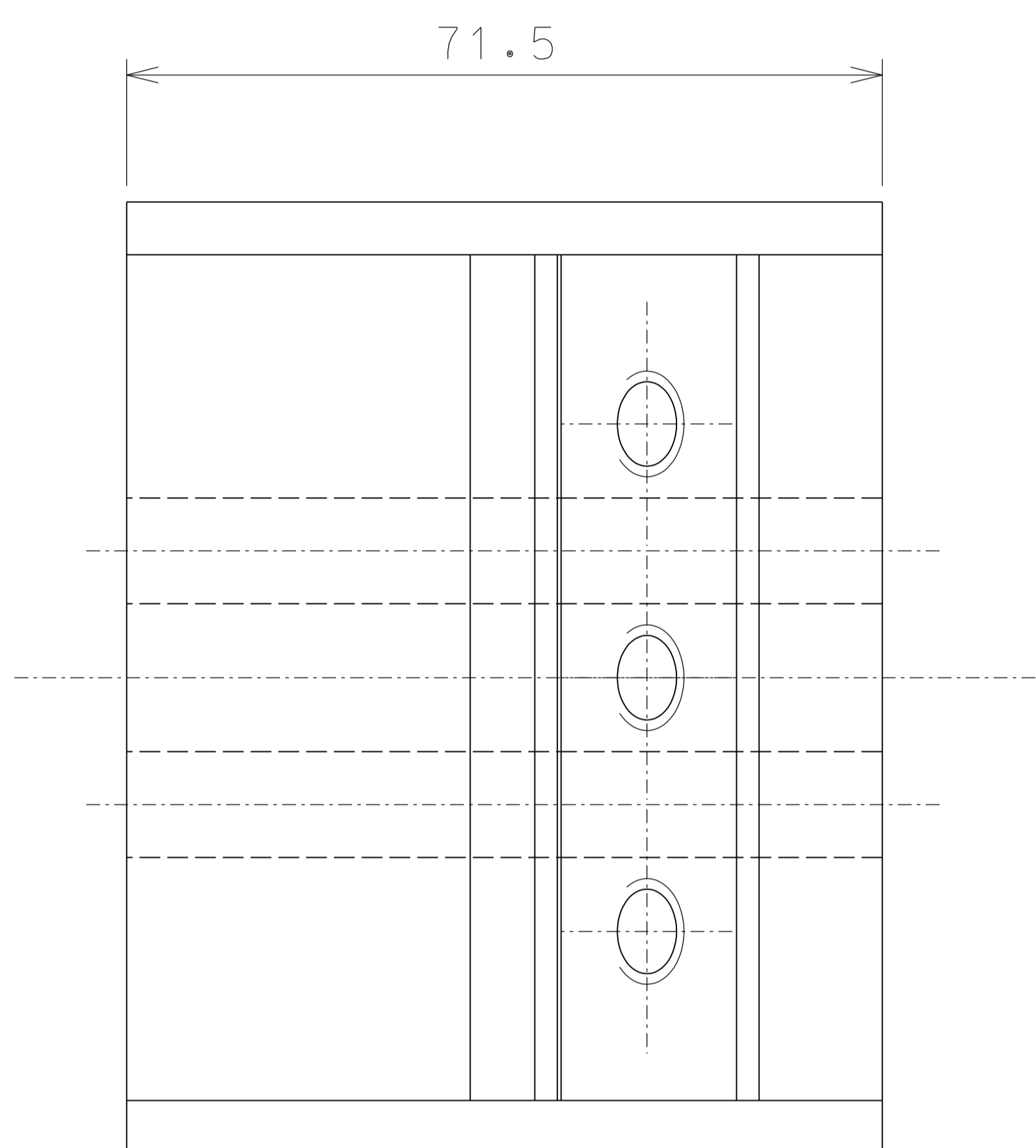
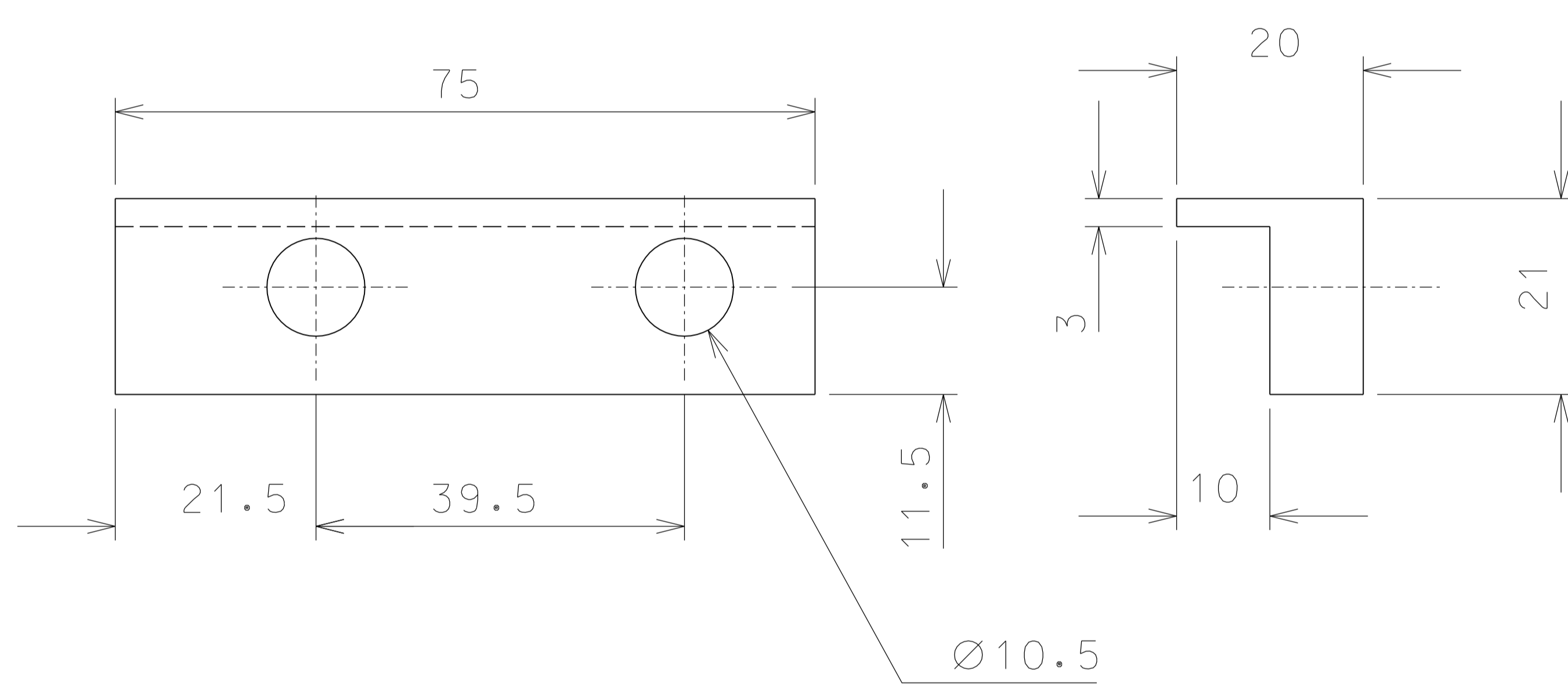

28

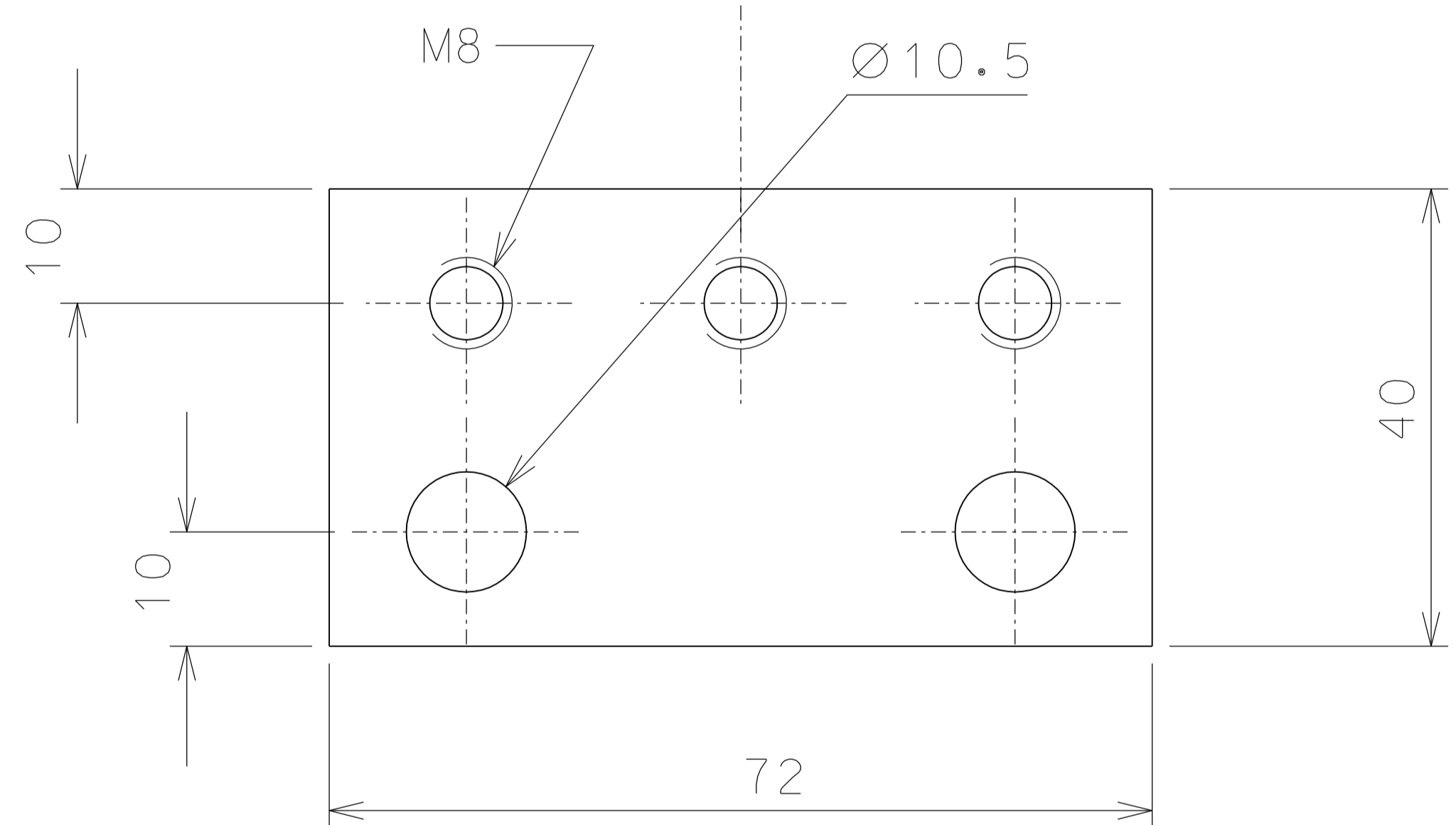
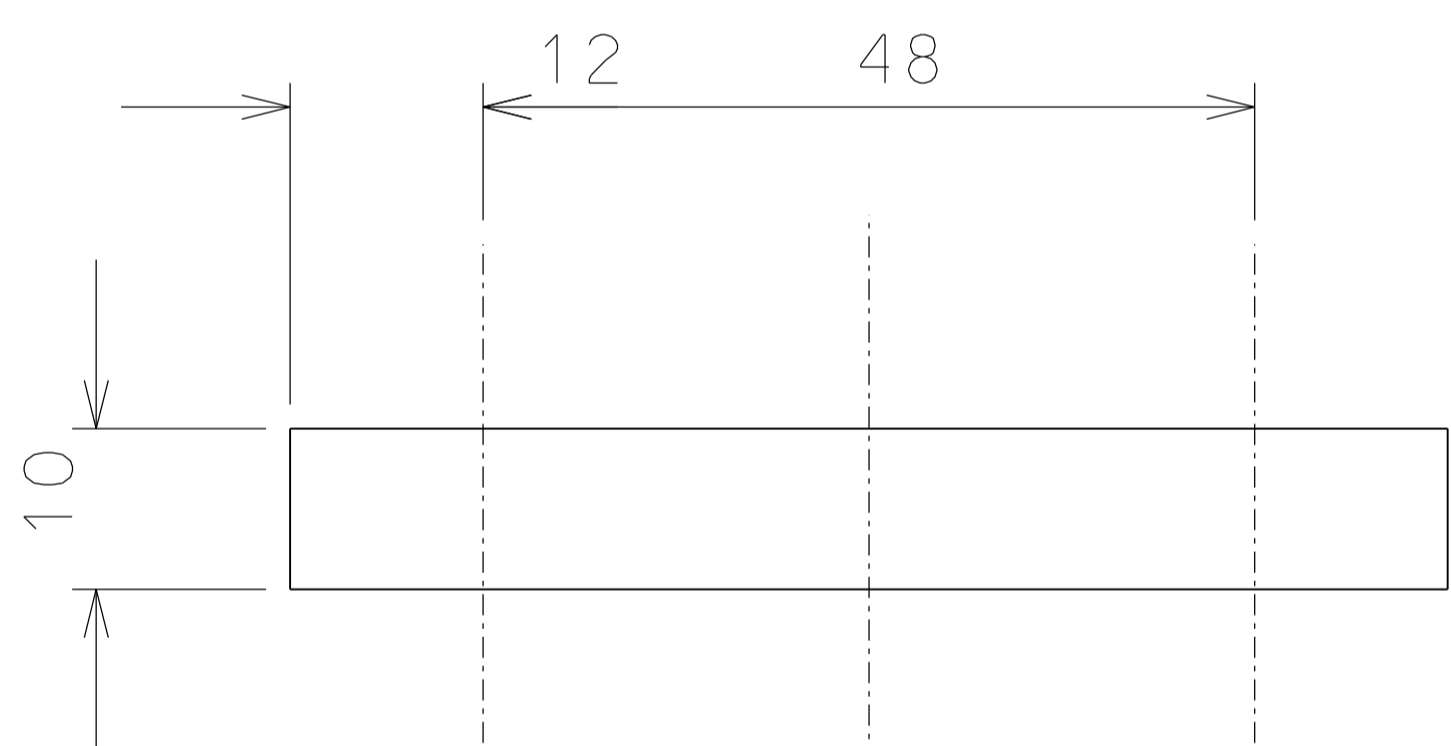

24 nickel flashing

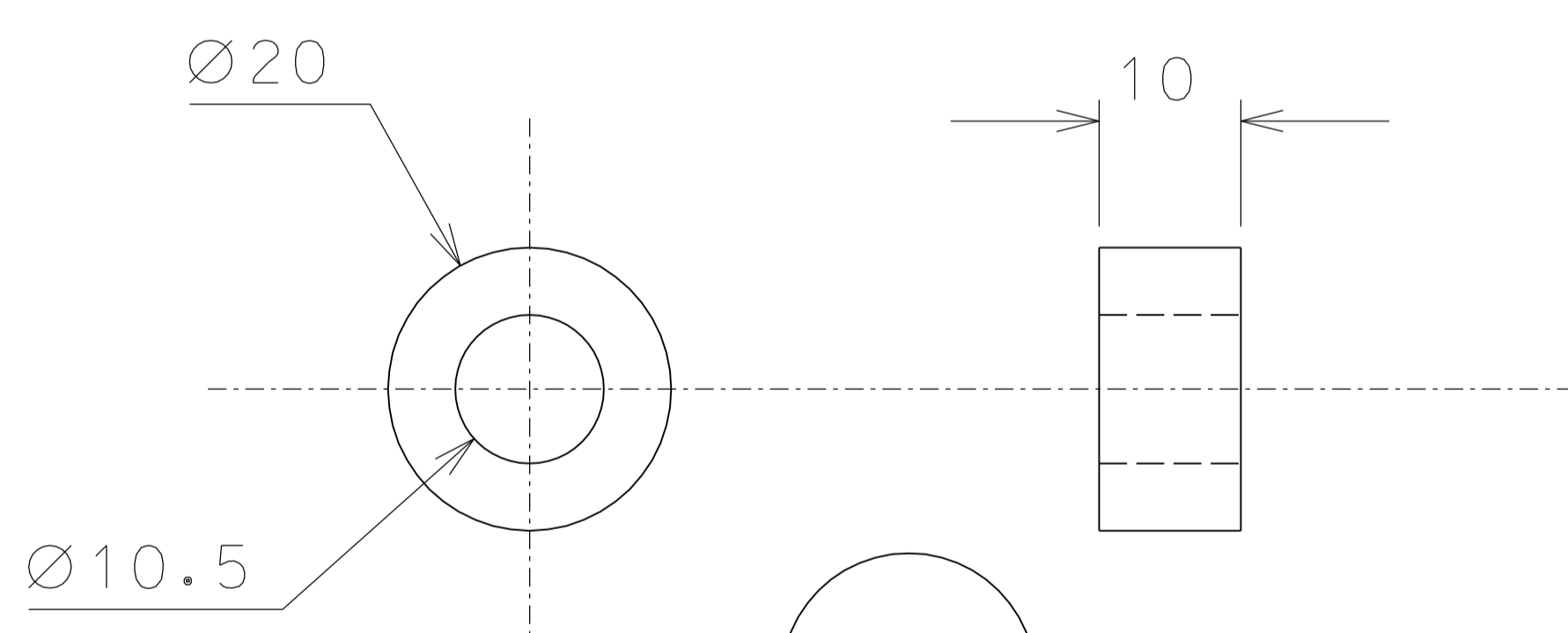

24.1 nickel flashing

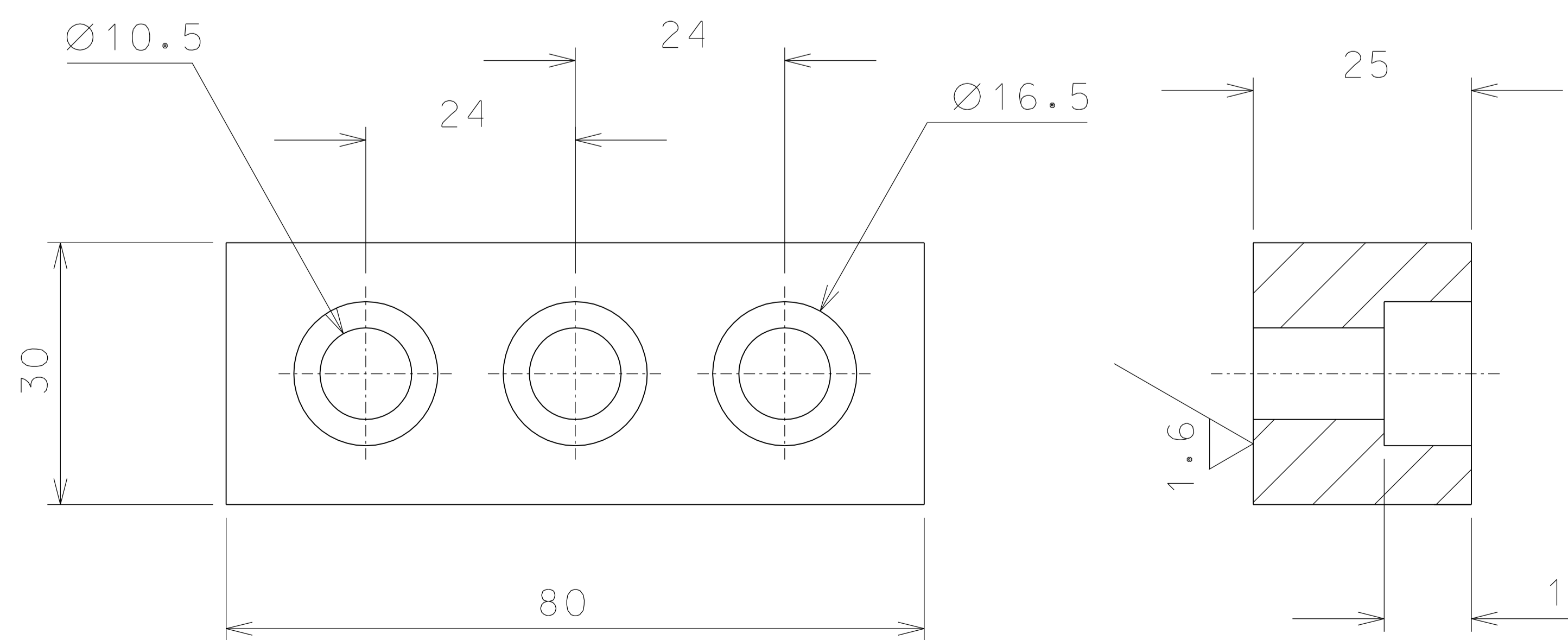

21

ref.	note	date	signature
	added part 24.1 and mod. part 24	03-11-06	
	added missing dimension	30-05-06	
	eliminated part 72	06-05-06	
	modified detail 26	09-04-06	
modifications			
ref.	pieces	mat. and treatments	scale
28	32	AISI 304	1/1
27	32	AISI 304	1/1
26	32	AISI 304	1/1
24	32	Fe 360	1/1
21	32	AISI 304	1/1
ref.	pieces	mat. and treatments	scale

General machining tolerances UNI 5307-63								
Dimensions	< 6	> 6-30	> 30-120	> 120-315	> 315-1000	> 1000-2000	> 2000-4000	> 4000
Linear Toll.	± 0.1	± 0.2	± 0.3	± 0.5	± 0.8	± 1.2	± 2	± 3
angular Toll.	± 1	± 30'	± 20'	± 10' referred to the shortest side				
designed for				R.De Salvo				
draw. by				G.Gennaro-PROMECC				
date				30-12-04				
title				LIGO PROJECT				
scale				1/1				
title				HAM-OPTICAL BENCH				
DETAILS FILTER				LIGO-D051123-05-D				
detail from				106		A 2		