

11 silver plated

Note for 19: Forced with lighth press fit into detail 17 after cleaning and before coiling

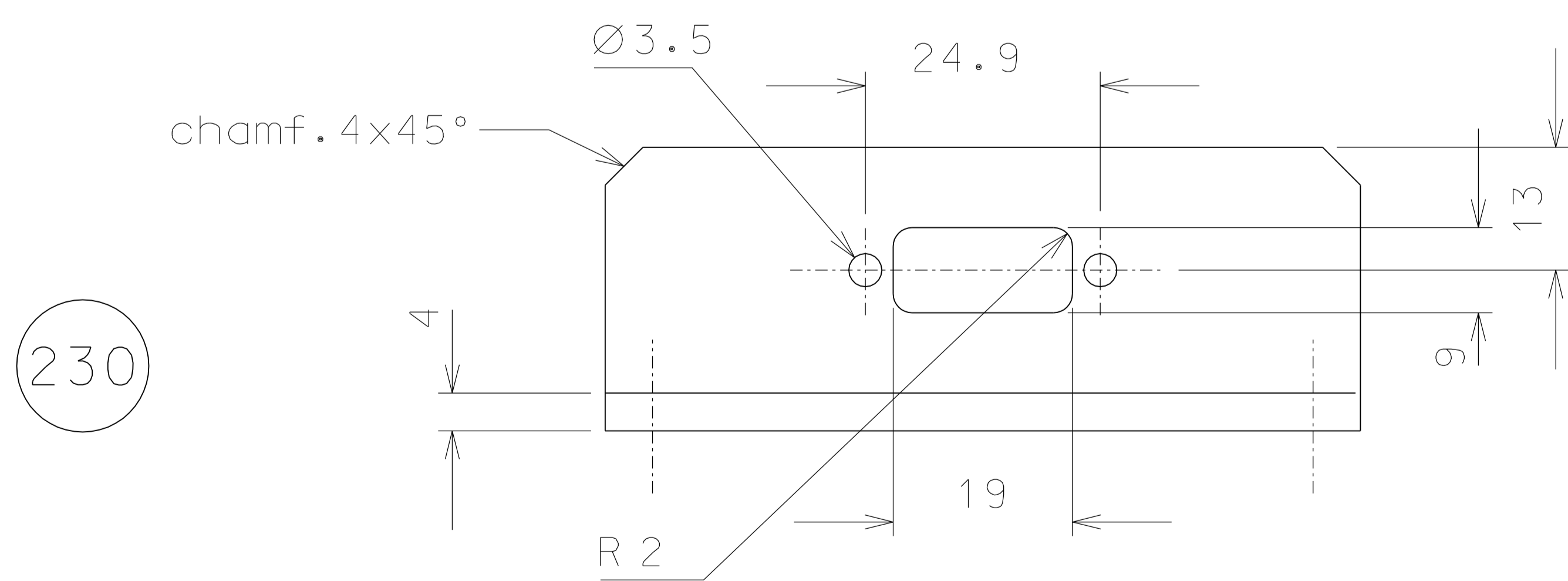

230

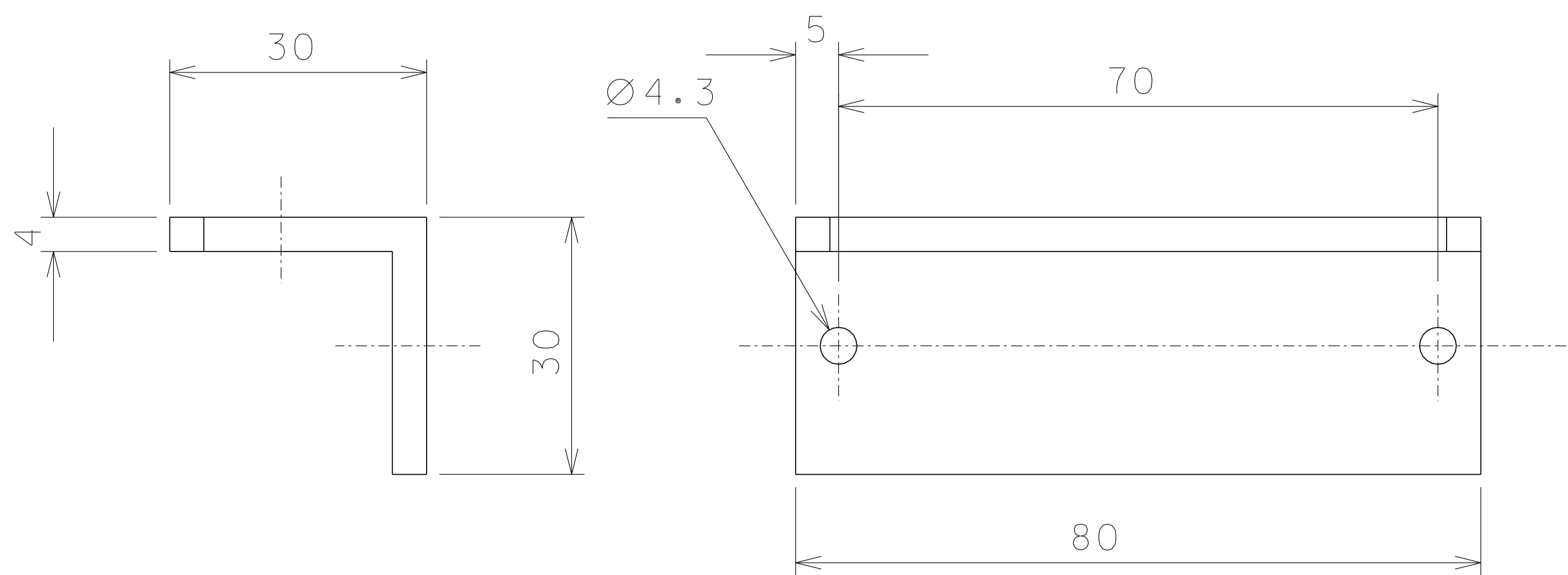

	modified part 19	19-11-06	
	modified part 12	02-10-06	
	modified part 11	01-10-06	
	modified part 11	12-09-06	
ref.	note	date	signature

modifications			
ref.	pieces	mat. and treatments	scale
230	4	AISI 304	1/1
20	64	EN 6082	1/1
19	4	AISI 304	1/1
12	4	EN 6082	1/1
11	4	AISI 316	1/1

General machining tolerances UNI 5307-63								
Dimensions	< 6	>6-30	> 30-120	> 120-315	> 315-1000	>1000-2000	>2000-4000	> 4000
linear Toll.	± 0.1	± 0.2	± 0.3	± 0.5	± 0.8	± 1.2	± 2	± 3
angular Toll.	± 1	± 30'	± 20'	± 10' referred to the shortest side				

designed for		R.De Salvo	
draw. by		G.Gennaro-PROMECC	
date		2-01-05	
title		scale 1/1	
HAM-OPTICAL BENCH		LIGO-D051124-10-D	
DETAILS FILTER		detail from 106 A 2	