

- NOTES:**
1. FOR GENERAL NOTES, ABBREVIATIONS AND LEGEND SEE DRAWING WA-S-001.
  2. SEE DESIGN DRAWINGS FOR STRUCTURAL MEMBER SIZE AND DIMENSIONS.
  3. ALL EXPOSED SHARP EDGES AND CORNERS SHALL BE GRIND SMOOTH.
  4. GALVANIZED MEMBER TO BE FIELD WELDED SHALL BE LEFT UNGALVANIZED A DISTANCE OF ONE INCH FROM AREA OF WELDING. THESE AREAS SHALL BE PAINTED WITH GALVANIZE COATING AFTER WELDING.
  5. SHOP-WELDED HANDRAIL SECTIONS SHALL NOT EXCEED 20'-0" IN LENGTH.
  6. ALL MISCELLANEOUS STEEL SHOWN ON THIS DRAWING SHALL BE GALVANIZED UNLESS OTHERWISE NOTED ON DESIGN DRAWINGS.
  7. PROVIDE CLOSURE PL BETWEEN STAIR TREADS.

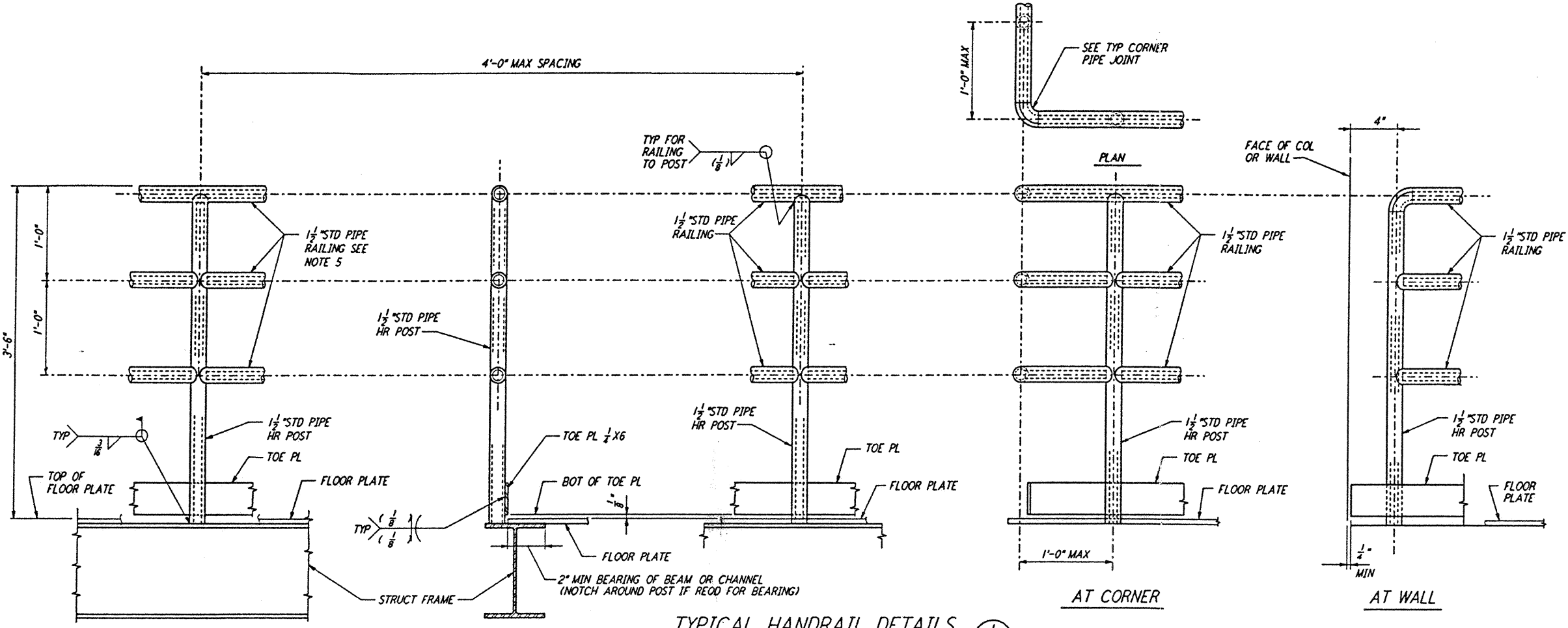

**TYPICAL HANDRAIL DETAILS** (1)

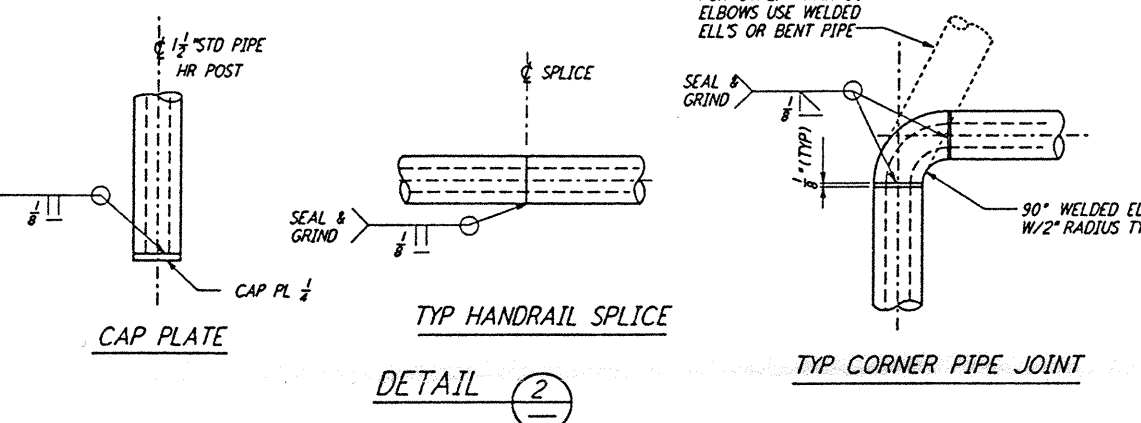

**DETAIL 2**

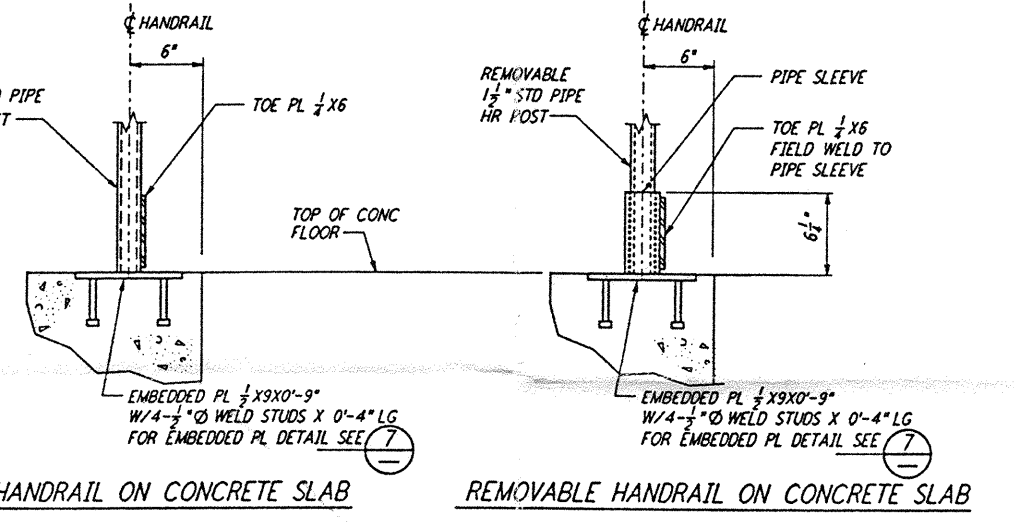

**DETAIL 3**

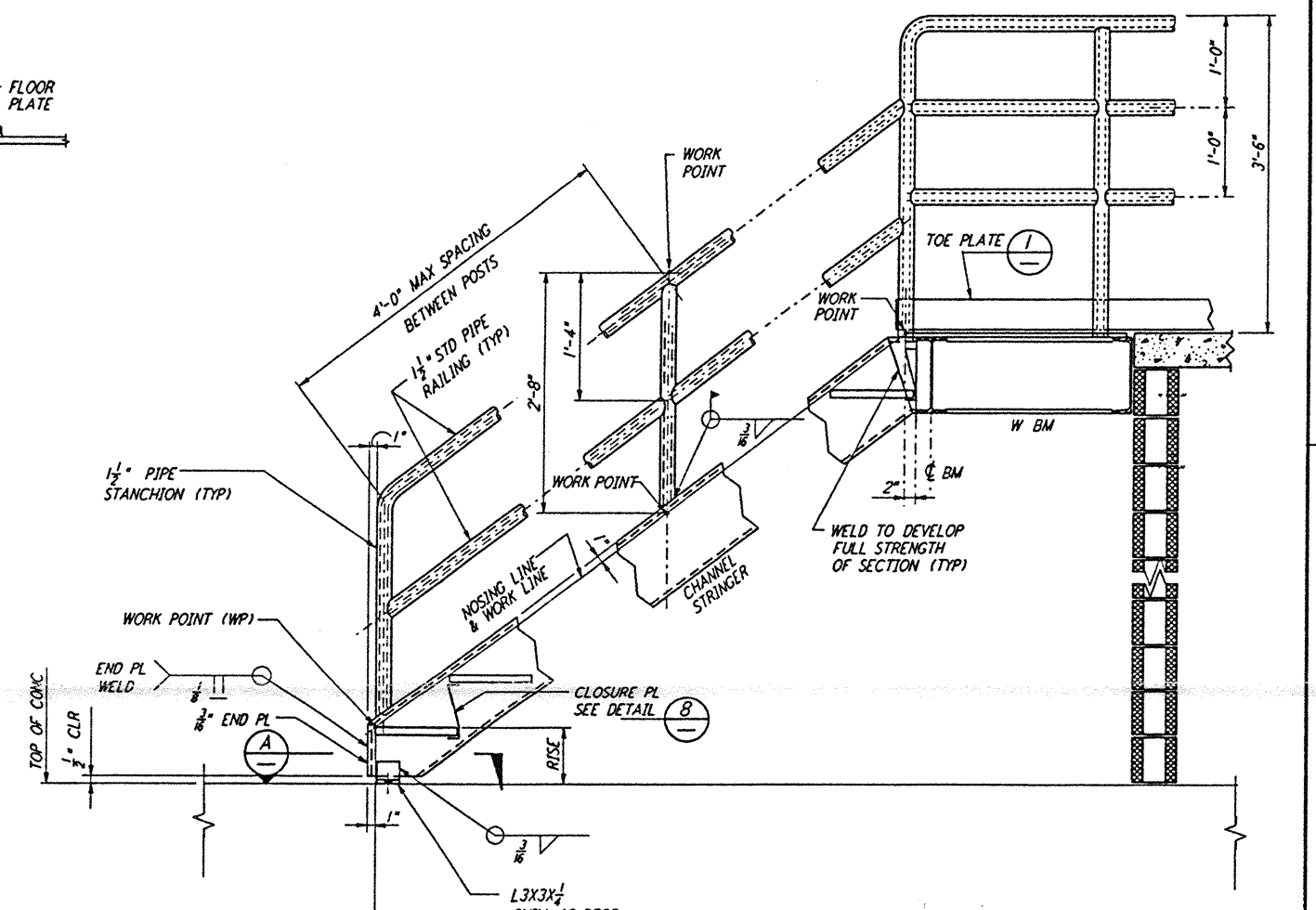

**TYPICAL STAIR DETAILS** (4)

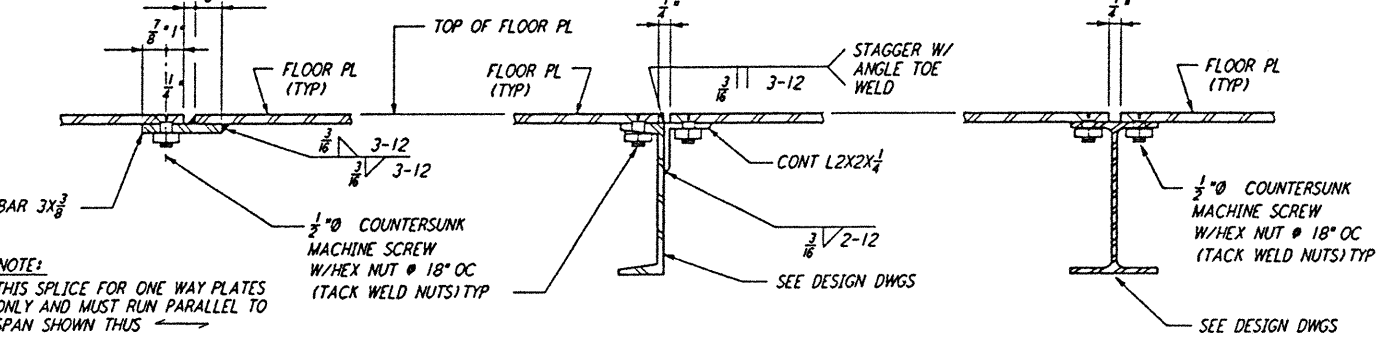

**TYP SPLICE CONN AT REMOVABLE FLOOR OR CHECKERED PLATE** (5)

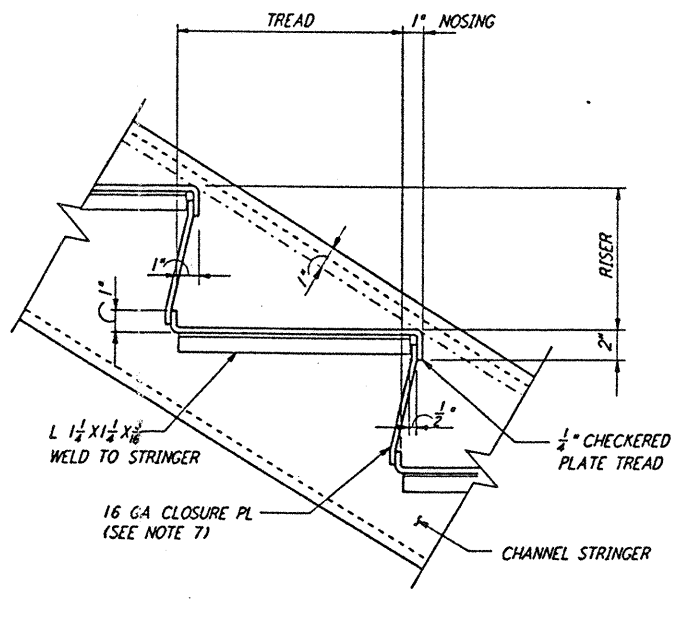

**CHECKERED PLATE TREAD DETAIL** (8)

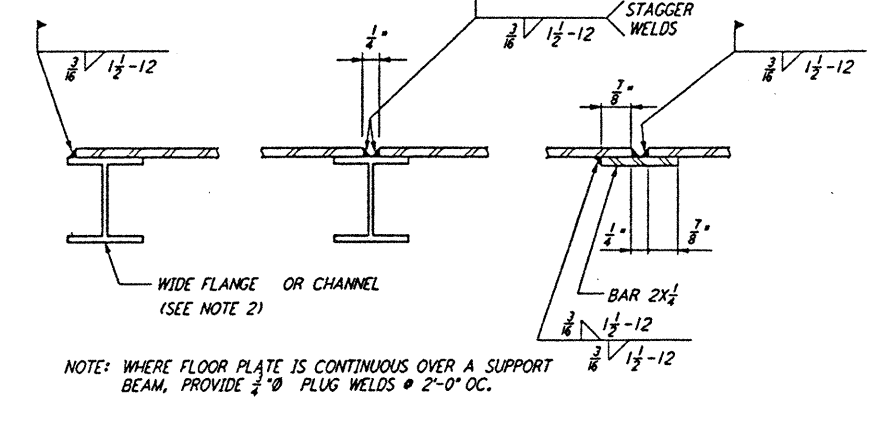

**TYP FIXED FLOOR OR CHECKERED PLATE** (6)

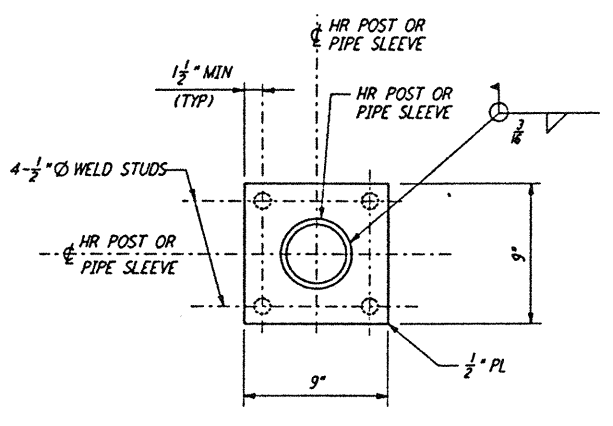

**EMBEDDED PLATE DETAIL** (7)

| NO. | DATE     | BY  | CHKD | ENGR | PROJ | DESCRIPTION               |
|-----|----------|-----|------|------|------|---------------------------|
| B   | 4-19-96  | MCS | sm   | PH   | STW  | FINAL DESIGN REVIEW & BID |
| A   | 10-21-95 |     |      | TDM  |      | PRELIMINARY DESIGN REVIEW |

| REFERENCES | DESCRIPTION |
|------------|-------------|
|            |             |

|          |     |
|----------|-----|
| DRAWN    | MCS |
| CHECKED  |     |
| ENGINEER |     |
| PROJ     |     |

**PARSONS**  
 100 WEST WALNUT STREET  
 PASADENA, CALIFORNIA

**LIGO**  
 CALIFORNIA INSTITUTE OF TECHNOLOGY  
 MASSACHUSETTS INSTITUTE OF TECHNOLOGY

LASER INTERFEROMETER  
 GRAVITATIONAL-WAVE OBSERVATORY  
 SITE NO. 1 - HANFORD, WASHINGTON

|   |       |                 |                |
|---|-------|-----------------|----------------|
| TITLE   | SCALE | CONTRACT NUMBER | PROJECT NUMBER |
| STRUCTURAL STANDARD STRUCTURAL STEEL STAIR & HANDRAIL DETAILS | NONE  | PP150969        | 8094           |
| SHEET NUMBER  |       |                 | ALTERNATE      |
| <b>WA-S-009</b>   |       |                 |                |

LIGO-D960294-B-D 1

This document and the design it covers are the property of PARSONS. They are loaned only with the borrower's expressed written agreement that they will not be reproduced, copied, loaned, exhibited, or used in any other way, except by written consent from PARSONS to the borrower.