

NOTES: (UNLESS OTHERWISE SPECIFIED)
 ① MARK SERIAL NUMBER APPROX. WHERE SHOWN BY ENGRAVING, DIE STAMPING, OR OTHER PERMANENT METHOD, 1/4 INCH HIGH LETTERING.
 ② FOR VENDOR INFORMATION, SEE TOP ASSEMBLY MATERIALS LIST D970006 OR D970007.

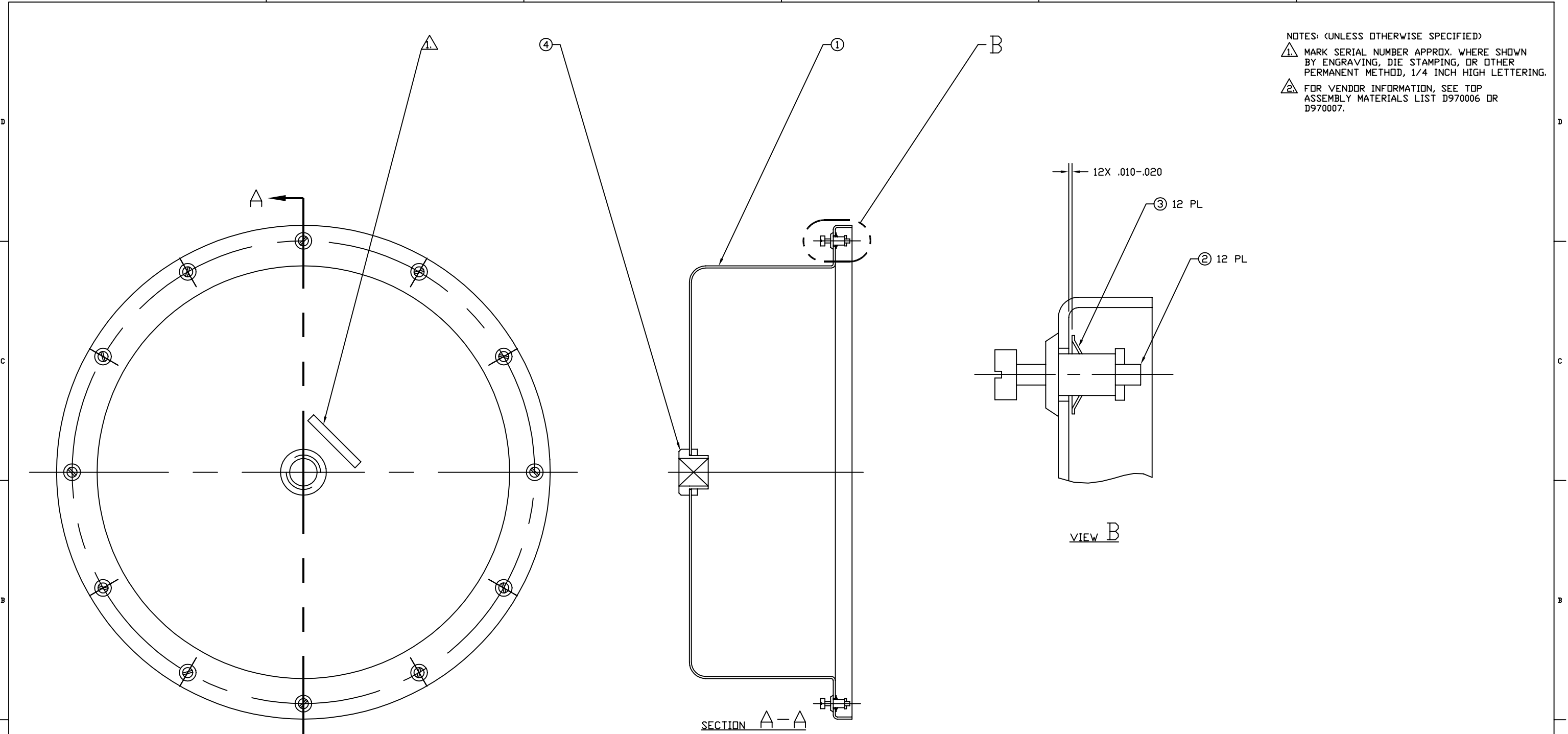

4	1	ZERO MFG. #ZSP 6-037-4	PRESSURE RELIEF VALVE	ALUM
3	2	CAMLOCK PROD'S. DIV #2600-LW-7	QUARTER TURN FASTENER RETAINING RING	SS
2	1	CAMLOCK PROD'S. DIV #26S51-5	QUARTER TURN FASTENER STUD	SS
1	1	D961417	COVER	-
REF.	QTY.	PART or DRWG No.	NOMENCLATURE or DESCRIPTION	MATERIAL

PARTS and MATERIAL LIST ②

UNLESS OTHERWISE SPECIFIED DIMENSIONS ARE IN INCHES		TOLERANCES: FRACTIONAL ± ANGULAR ± ANGULARMACH ± BEND ± TWO PLACE DECIMAL ±		THREE PLACE DECIMAL ± FINISHED SURFACE RMS BREAK CORNERS IN OUT REMOVE ALL BURRS		MATERIAL:		HEAT TREAT:		FINISH:		B DCN E970061		A DCN E960157		01 RELEASE FOR FAB		00 PRE-RELEASE		CDYNE		CDYNE		5-7-97		CDYNE		CDYNE		2-14-97		CONLEY		CONLEY		CONLEY		CONLEY		12-11-96		CAD FILE		SIZE/DWG. NO.		SCALE		SHEET	
D961420-B.dwg		B		D961420-B-D		NTS		1		1		1		1		1		1		1		1		1		1		1		1		1		1		1		1		1		1		1					