

REVISIONS			
REV.	DESCRIPTION	APPROVED	DATE
A	RELEASED		
B	CHANGED NOTES		
C	ADDED 6X HOLES THRU; 12X 1/4-20 UNC; CHANGED TITLE; CHANGED MAT'L DESCRIPTION TO GATES SOLID PULLEY 60H100	AJL	9/10/96

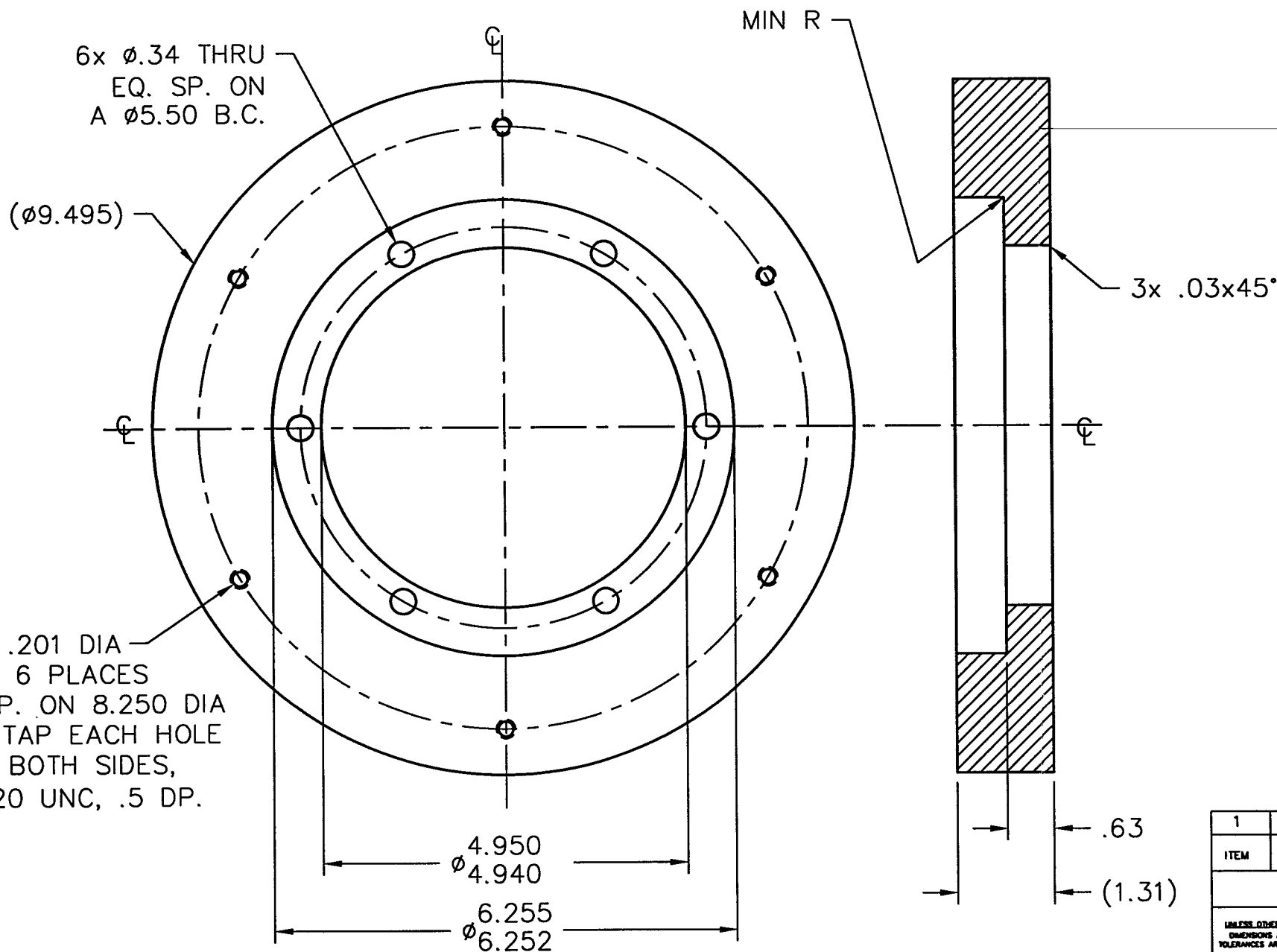

6x ϕ .34 THRU
EQ. SP. ON
A ϕ 5.50 B.C.

(ϕ 9.495)

MIN R

3x .03x45°

DRILL .201 DIA
THRU, 6 PLACES
EQ. SP. ON 8.250 DIA
B.C.; TAP EACH HOLE
FROM BOTH SIDES,
1/4-20 UNC, .5 DP.

4.950
 ϕ 4.940
6.255
 ϕ 6.252

.63
(1.31)

DEC 19 1996

VG # V049-8-538
L140-D961654-C-V

1	1	60H100	GATES SOLID PULLEY (MOTION INDUSTRIES) Δ
ITEM	QTY.	PART NO.	DESCRIPTION
PART LIST			MATERIAL SPECIFICATION
UNLESS OTHERWISE SPECIFIED DIMENSIONS ARE IN INCHES TOLERANCES ARE: DECIMALS ANGLES FRACTIONS X.X ± .01 ± 10' 125' X.XX ± .005 X.XX ± .005 UNSPECIFIED FILETS: R.015 BREAK EDGES .010 ± .030' REMOVE ALL BURRS		CONTRACT OR SALES ORDER NO. APPROVALS DATE 11#	
THIRD ANGLE PROJECTION		G44E, G48E	
DO NOT SCALE DRAWING		ENGINEER ZH 2-14-96	
CADD FILE NAME		B103311C	
SCALE: NONE			REV. C

NOTES:
FINAL CLEANING TO MEET
GNB SPEC. PER UHV

TITLE
 Δ PULLEY, CLUTCH
G44E, G48E
DWC NO. 103311
SHEET 1 OF 1