

MACHINE DOWN BOTH FLANGES TO 1" AS SHOWN

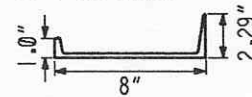

RAW MATERIAL FOR PC. 10 SHALL BE 6061-T6 EXTRUDED ALUMINUM 8" X .25" AMERICAN STANDARD CHANNEL. EACH SEMI-CIRCLE REQUIRES APPROX. 6'-8" OF CHANNEL PLUS THE LENGTH REQ'D FOR ROLLING. (FOUR SEMI-CIRCLES ARE REQ'D.)

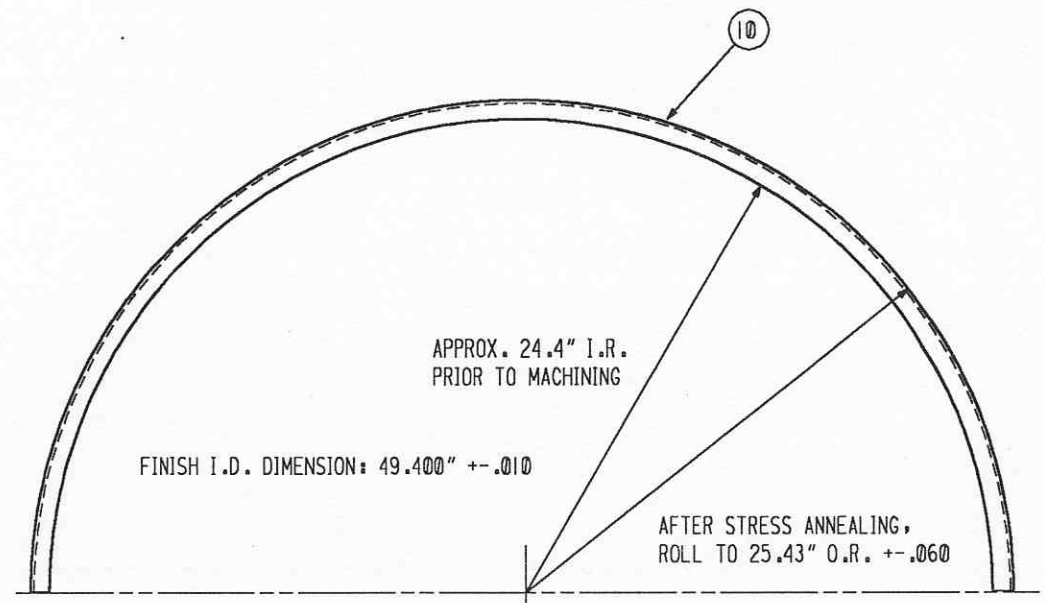

LEAVE ENOUGH EXTRA CIRCUMFERENCE TO REROLL TO THE OUTSIDE RADIUS AFTER RETEMPERING

1. PLACE THE REQUIRED LENGTH OF CHANNEL FOR ROLLING ON A MILL AND MACHINE THE FLANGES DOWN TO A FINAL DIMENSION OF 1.00".
2. STRESS ANNEAL THE LENGTH OF MACHINED CHANNEL TO A ZERO TEMPER.
3. ROLL THE STRESS ANNEALED CHANNEL TO THE OUTSIDE RADIUS SHOWN.
4. RETEMPER THE ROLLED CHANNEL TO A T6 TEMPER.
5. REROLL THE TEMPERED CHANNEL TO THE OUTSIDE RADIUS SHOWN (IF NECESSARY).
6. MACHINE THE ENDS SQUARE AND RADIAL TO GET A 180 DEGREE ARC (USE TWO SEMI-CIRCLES AND MATCH MARK THE ENDS SO AS TO ACHIEVE A TRUE AND ROUND CIRCLE).
7. WELD THE ASSEMBLIES A, B, C, AND D ONTO THE SEMI-CIRCLES AS SHOWN ON THE DRAWINGS. THE WELDS ARE TO BE APPLIED ONLY BETWEEN THE RADIUS ON PC. #2 AND PC. #10 TO PREVENT DISTORTION OF THE ROLLED CHANNEL.
8. PLACE AND LOCK THE TWO SEMI-CIRCLES TOGETHER.
9. BORE THE HOLES FOR THE FOUR FITTINGS AND INSTALL THE FITTINGS.
10. PLACE THE LOCKED RING ONTO A BORING TABLE AND CENTER IT WITH THE OUTSIDE DIAMETER. BORE THE INSIDE DIAMETER TO THE FINISH DIMENSION SHOWN.

SEE DWG ER600 FOR ORIENTATION ON CIRCUMFERENTIAL LEAK TEST BOX.

PUMPING PORT 100 ISO

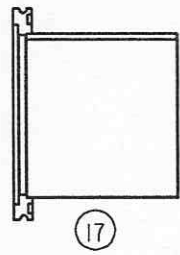

CALIBRATED LEAK CHECK PORT 50KF X 25 KF

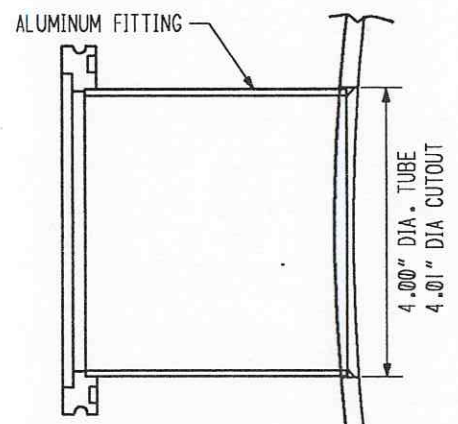
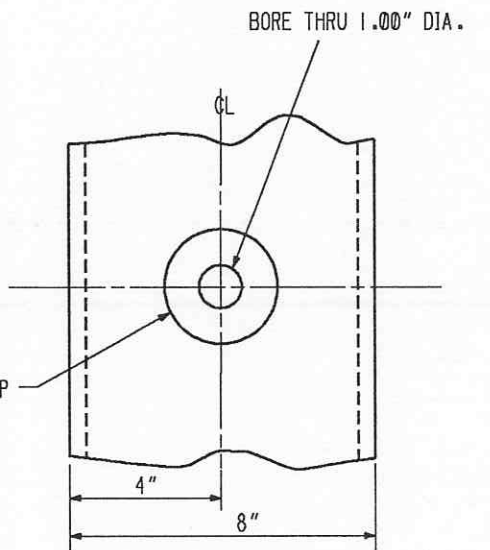
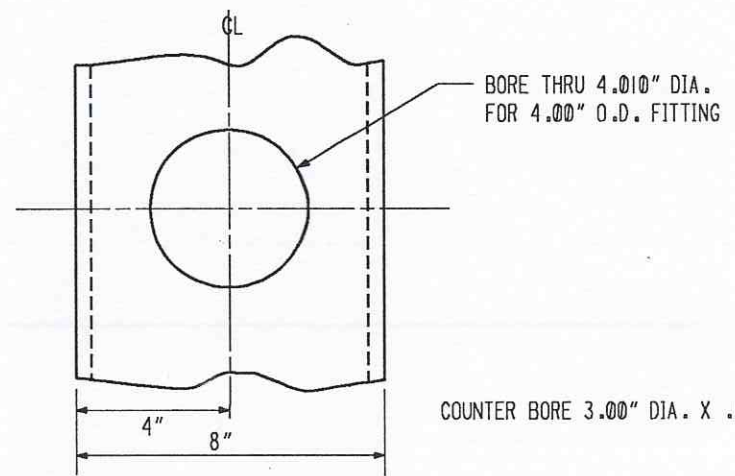
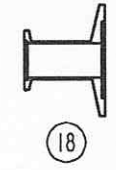

CUTAWAY VIEW OF ISO 100 HALF NIPPLE INSERTED AND WELDED INTO THE ROLLED RING

INSERT THE ALUMINUM ISO 100 HALF NIPPLE APPROXIMATELY HALF WAY THROUGH THE THICKNESS OF THE ROLLED RING AND WELD THE NIPPLE TO THE ROLLED RING FROM THE INSIDE OF THE RING.

INDICATES CHANGE FROM PREVIOUS ISSUE

Supplier's/Purchaser's No.		Contract No.	
CBI		953571	
<b>LIGO-BEAM TUBE</b>			
HANFORD, WA & LIVINGSTON, LA			
CIRCUMFERENTIAL LEAK TEST BOX			
NOZZLE DETAILS			
Customer's No.		Contract No.	
By CLD Chkd DMD Date 2-26-96		953571	
M. L. TELLALIAN		Dwg. ER604 Rev. 1	
Engineering Supervisor		Sheet	
<b>LIGO-D970057-01-B</b>			