

NOTES: (UNLESS OTHERWISE SPECIFIED)
 1. BREAK ALL SHARP EDGES.

2. CHAMFER INSIDE POCKET AS REQUIRED FOR WELDING ON NEXT ASSEMBLY.

REV	DATE	DRAWN BY	CHECKED	DCC	DCN/DESCRIPTION
A	8/28/98	C. Conley			E980218-00/INITIAL RELEASE
B	12/17/01	J. Romie			E010369/ADD J PREP

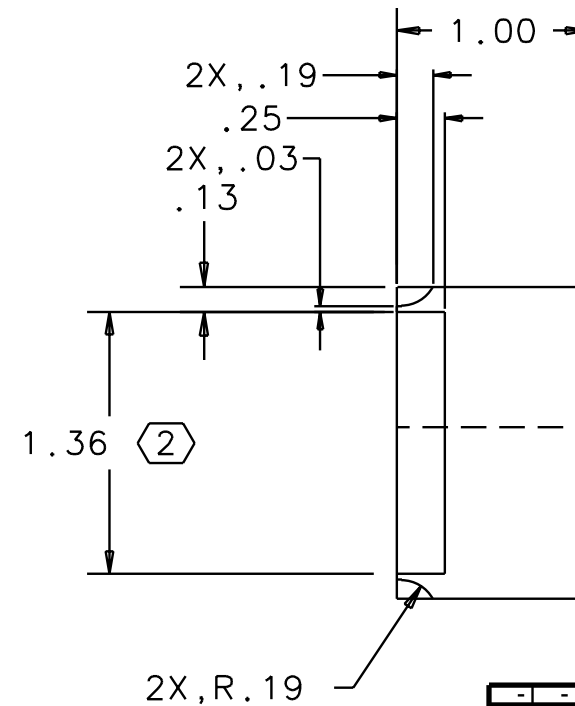
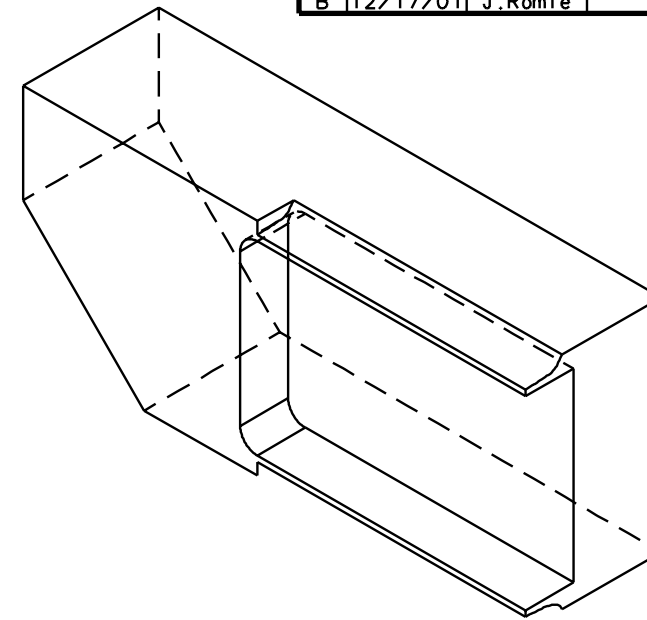
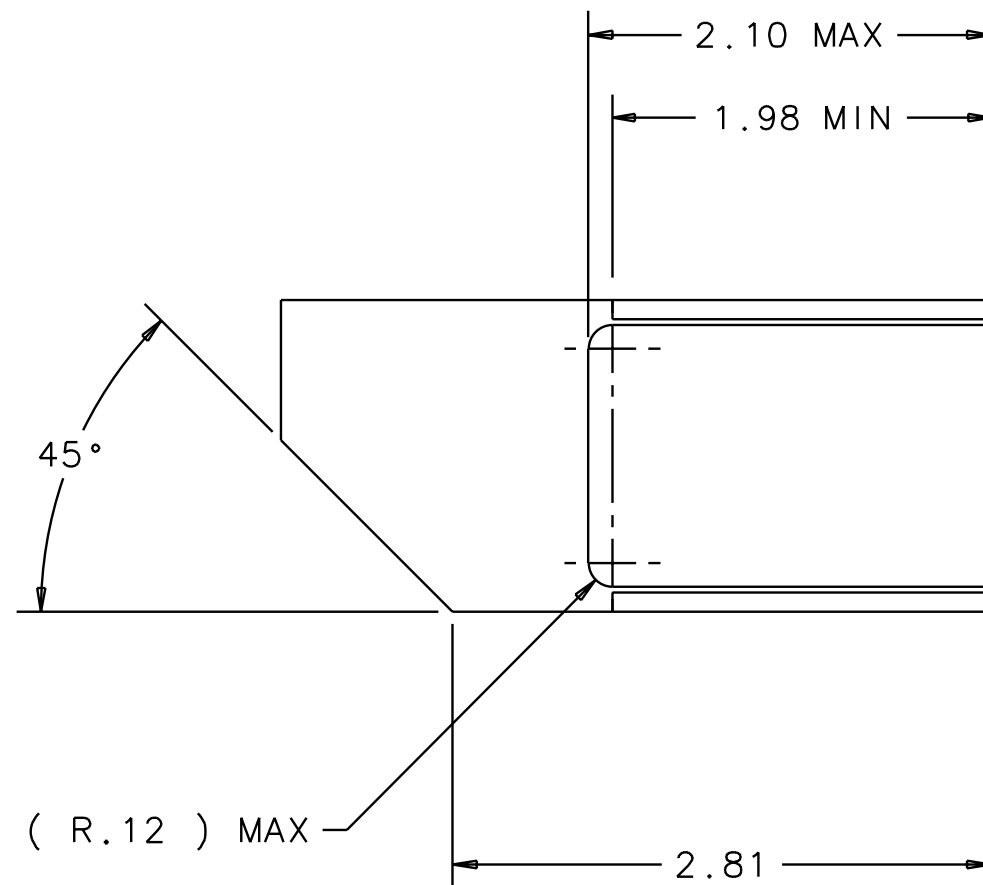
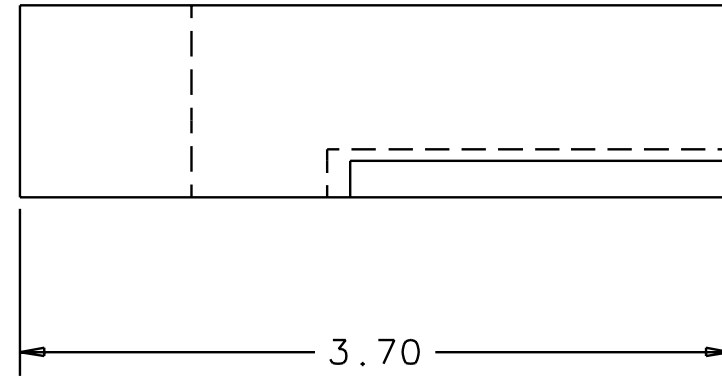

QTY REQD	FSCM NO	PART OR IDENTIFYING NO	PART	NOMENCLATURE OR DISCUSSION	MATERIAL SPECIFICATION	ITEM NO
-	-	-	-	-	304 STAINLESS STEEL	-
PARTS LIST						
DRWN	C. Conley	DATE	8/28/98	CALIFORNIA INSTITUTE OF TECHNOLOGY MASSACHUSETTS INSTITUTE OF TECHNOLOGY		
CHKD		LIGO PROJECT				
ENGR		1-Deas CAD file: D970558_A.dwg				
APPD		dcc file: D970558-A.pdf				
UNLESS OTHERWISE SPECIFIED:				TITLE		
DIMENSION UNITS ARE inch (mm)				LOS3 BRACKET SUPPORT		
TOLERANCES ARE:				SCALE: 1/1		
X.XXX: ± 0.005				SIZE DRAWING NUMBER		
X.XX: ± 0.01				B D970558-B-D		
ANGLES: ±0.5°				SHEET		
NEXT ASSEMBLY: D970508				1 of 1		